

Document information

Info	Content
Keywords	Analog Switches, Digital Switches, NX Family
Abstract	This document describes the configurations, features and benefits of NXP's analog and digital switches. Featured products and applications are also discussed.

Revision history

Rev	Date	Description
00	20081126	First draft written by Ali Zeeshan
01	2009/03/15	New switch configurations, test circuits, and applications added. Frequency response for NX5DV330 was added and portfolio tables are updated. Changes and additions are made by Ali Zeeshan based on feedback from Michael Lyons.

Contact information

For additional information, please visit: <http://www.nxp.com>

For sales office addresses, please send an email to: salesaddresses@nxp.com

1. Introduction

Switching is the most fundamental function in electronics and plays a vital role in every system. Analog and digital bus switches are used in many industrial instruments and consumer devices to implement test interfaces, multiple peripheral and host selection functions, power and clock management, sample and hold circuits, test and debug interfaces, etc. Single Pole Single Throw (SPST), Single Pole Double Throw (SPDT), and Double Pole Double Throw (DPDT) are some of the switch configurations widely used in the industry today. Figure 1 shows some of the common switch configurations. NXP uses innovative circuit and package designs to offer an extensive portfolio of analog switches in single package with sub-ohmic on state resistance for different applications. In this paper, features and applications of NX and LVC analog switches and CBT digital bus switches are discussed in detail

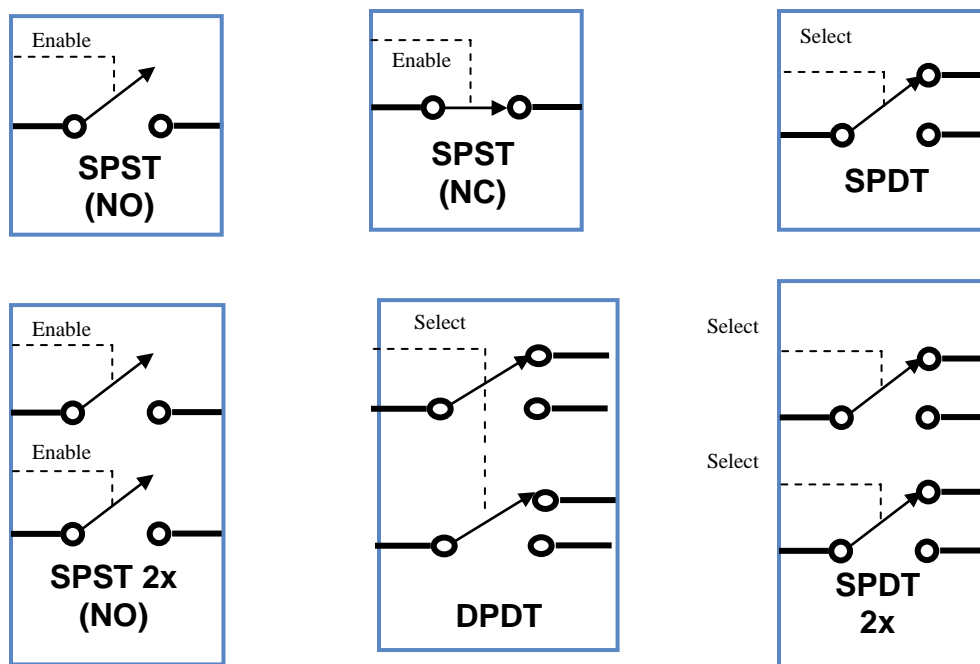

Figure 1. Common Switch Configurations

NX3 analog switches consume very low power with maximum supply current 'I_{cc}' of 690nA at 85C. Some of these switches have a select pin and some have enable pin, for digital control by a master in the design. Schmitt trigger action at select and enable control pins results in higher reliability in noisy conditions. Both normally closed and normally open switch configurations are offered, which find their way in different applications. For example, normally closed switches are commonly used in audio system of TV. Normally, the audio is routed to speakers at all times as long as the switch is closed but when

the mute button is pressed, the switch is opened and audio is muted. On the other hand, normally open switches can be used to isolate multiple peripherals from the source and select the required one. For example, video signals can be routed from digital signal processor to external LCD of a notebook PC via docking station, by closing a normally open switch.

2. Applications in Mobile Phones

Figure 2 shows the block diagram of an audio system in a multi-mode cell phone. A dual SPDT switch can be used to route the audio signals from either baseband processor to speaker.

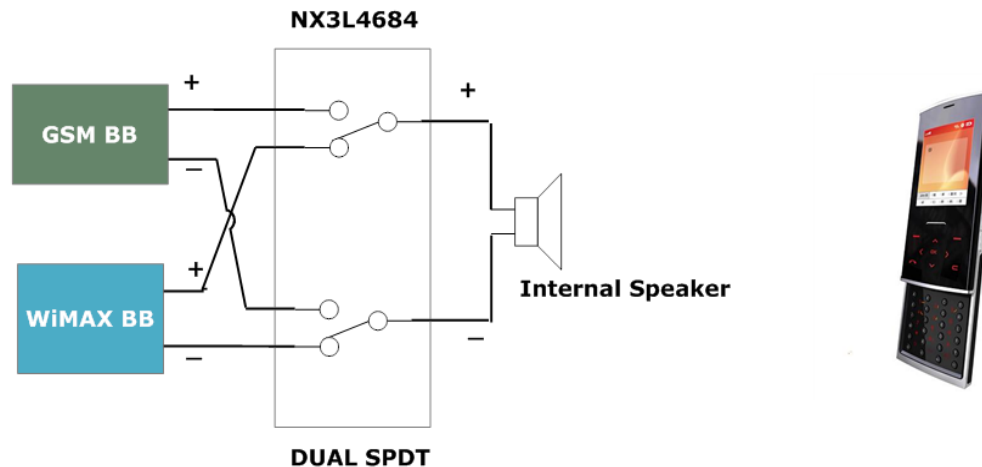

Figure 2. Analog Switches in Cell Phone

Another common use of SPDT switches is to wirelessly route the audio signals between cell phone and an external hands free device, as shown in figure 3 below:

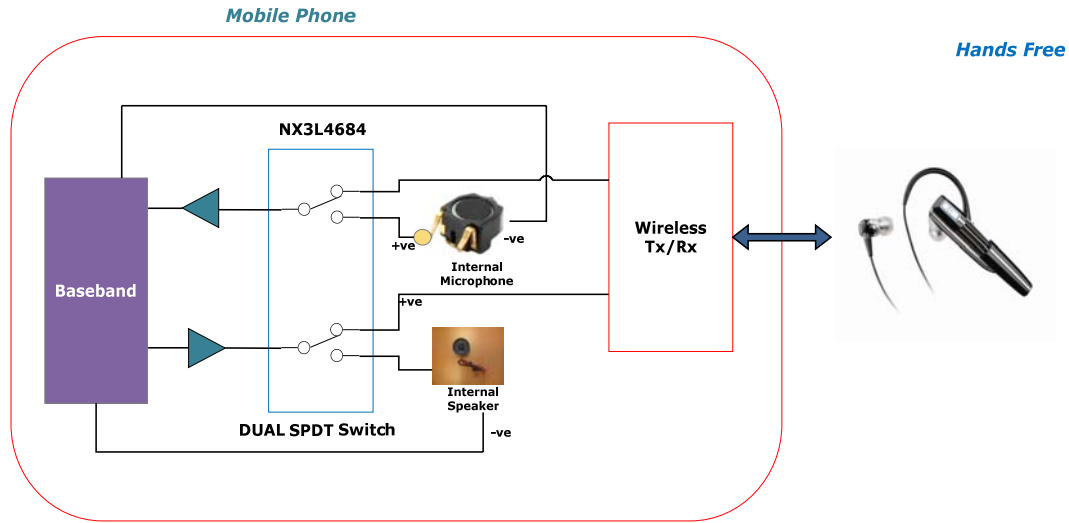

Figure.3 Dual SPDT Switch in hands free application

Although many baseband ICs have integrated voice CODEC with support for switching between internal and external speakers and microphones, but use of discrete analog switch avoids any pop up or clicking noise during switching.

3. Features and Benefits of Analog Switches

On state resistance is the resistance offered by switch to the signal in closed/on state. Circuit in figure 4 can be used to measure the voltage across a SPST NX3 switch and current through it. The measured voltage is divided by switch current to find R_{on} . On state resistance affects the amplitude of switch signals. With low on resistance, NX3 switches greatly reduce signal attenuation.

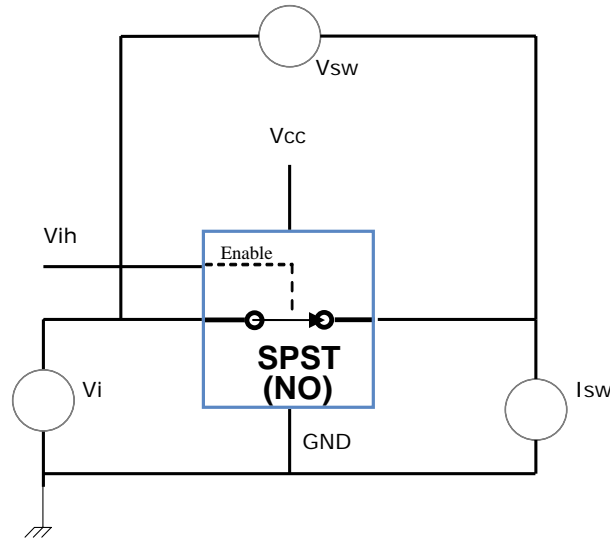

Figure. 4 Test Circuit for measuring Ron

Flatness of a switch can be defined as the largest delta Ron when switch voltage is swept through its specified range. Resistance flatness can significantly affect the total harmonic distortion. With low on resistance flatness of NX3 switches, total harmonic distortion in a design can be reduced and high frequency signals can be passed without loss. Figure 5 shows the flatness for ON resistance of NX3V family of switches.

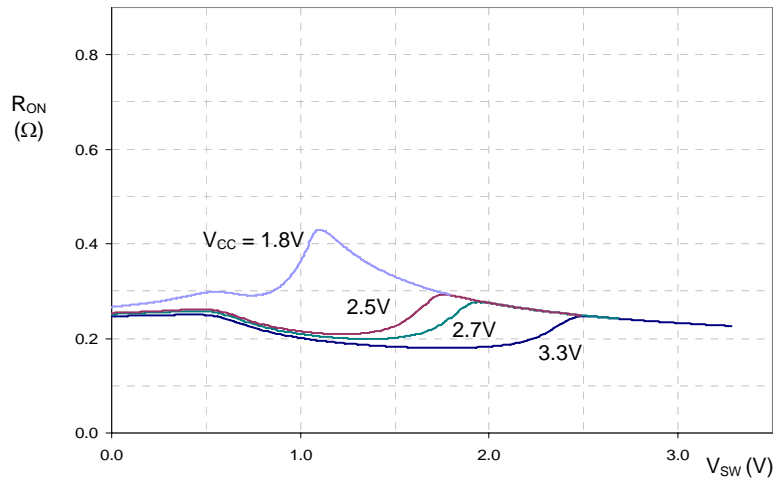

Figure. 5 Low Ron Flatness for NX3V Switches

Off state isolation and charge injection are other key dynamic characteristics of analog switches. Off isolation is a measure of separation between input and output terminals of a switch, when channel is off. It can be estimated by using a test circuit as shown in Figure 6. Typical value of R_L resistor is 50 Ohms. Voltage of function generator at switch input is adjusted to get 0dBm level. dB meter connected to the output of off channel measures the off isolation of channel.

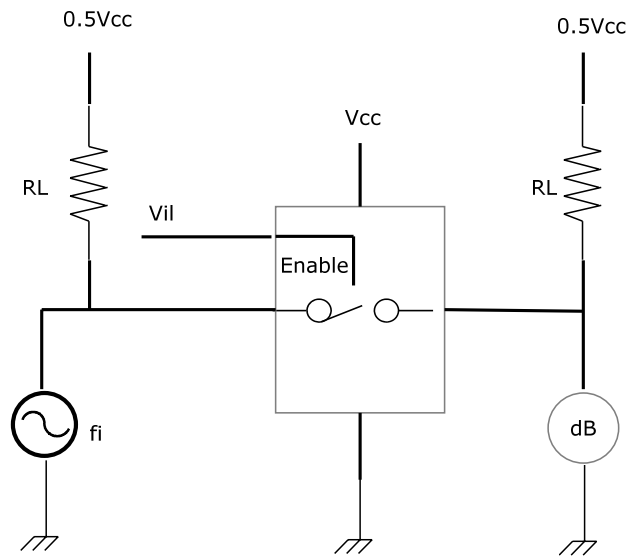

Figure. 6 Test Circuit for measuring Off Isolation

NX3 switches exhibit excellent off state isolation of -90dB. As the switch turns on or off, small amounts of charge can be injected from digital control signal in the path of analog switch signals. Low charge injection (3pC minimum) and less enable/disable times (as low as 14ns and 4ns respectively) for NX3 switches ensure a fast On/Off control with minimal noise induced in the data signal path for applications like sample and hold circuits. In portable applications with frequent direct contact between user and device, the probability of generating a high ESD pulse increases significantly. Therefore, it becomes important to use the components with higher ESD tolerance without compromising the size. NX3 switches are specified for Human Body Model ESD protection of (up to) 7.5kV per JESD22-A114E Class 3A standard.

The die size of NX3 switches is optimized to fit in extremely small innovative Picogate and leadless Micropak packages without compromising the low on state resistance. Both Picogate and Micropak packages have higher mechanical strength, and better foot print to contact area ratio as compared to most of the standard logic packages available in the industry. The higher ESD protection and smaller size are ideal features of switches for handheld and portable system design. A six pin Micropak typically measures 1.45 square mm, which is 56% smaller than a six pin TSSOP package. Furthermore, Micropak packages have the same size as that of WCSP packages but offer 35% greater contact with printed circuit board. NX3 switches are AEC-Q100 grade 1 qualified to ensure high quality and reliability in various applications including automotives.

4. Application in Sample and Hold Circuit

Figure 7 shows the use of NX3L1T66* analog switch in a sample and hold circuit. 'T' variant parts of NX3L family integrate the voltage translation function for control pin and allow the use of 1.8V control signal, while the switch is still powered by 3.3V. Conversely, a control voltage signal higher than supply voltage can also be used.

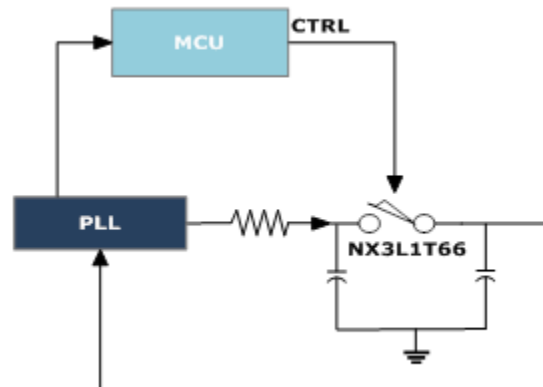

Figure. 7 NX3L1T66 in Power Conservation Circuit

This circuit can be used to conserve total power in different systems including industrial automation and motor control applications. The switch is controlled by 1.8V output of microcontroller unit, which in turn controls the time constant for decay of capacitor voltage. In this way, the output of PLL clock is held constant for value of RC time constant, and the total power consumption of system is significantly reduced. The power savings from this circuit can be realized in various scenarios, when input frequency of a PLL sub system is not expected to change for known times. With a typical low leakage current of 50nA at control input and switch I/Os, NX3 switches reduce the signal loss and false switching in monitoring applications. Low leakage current also results in longer hold times to minimize the sampling errors in sample and hold applications. Sample and Hold circuits are commonly used in analog to digital and digital to analog conversion blocks of many devices like electronic music synthesizers, image sensors, DVD players and digital TV sets etc. An example is a mobile WiMAX CPE modem which uses different clocks generated by PLL from a master system clock, to exchange data with the base station over different time division multiplexed channels. Higher frequency clock is used for wider channel bandwidth and the PLL output remains the same as long as the channel bandwidth does not change.

5. Frequency Response

An analog switch can be modeled as a first order low pass filter. Frequency response of filter is used to estimate the available channel bandwidth. Cutoff frequency is the frequency at which signal is reduced by 3dB. It is typically used as the signal bandwidth of switch. Signals with frequencies above this value are filtered out and the associated data is lost. Figure 8 shows the cut off frequency of 420MHz for a high bandwidth video switch (NX5DV330) from NXP. NX5DV330 is a 4PDT high speed TTL compatible video mux/demux with a typical supply voltage of 5V. All four switches in package can be quickly turned on and off with a single enable pin. A digital select pin 'S' is used to select the I/O channel. Higher off state isolation, wider signal bandwidth and lower cross talk are key features of NX5DV330. Very small, 16-pin SO, SSOP and TSSOP packages are available for the switch.

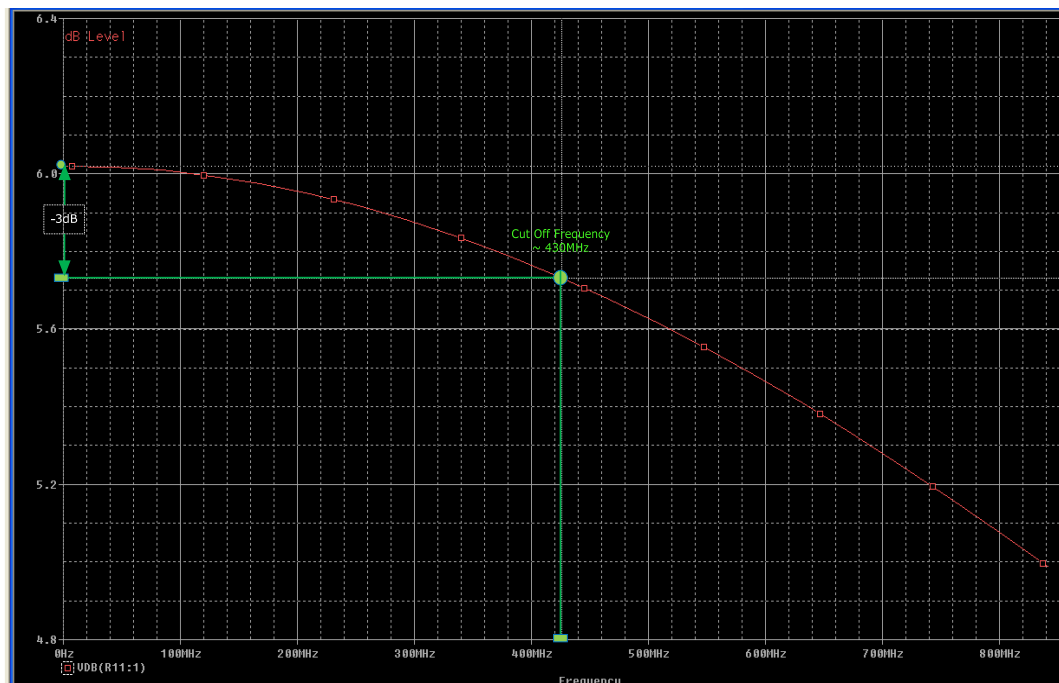

Figure.8 Cut Off Frequency of NX5DV330 Video Switch

NXP offers a variety of analog switches with signal bandwidth as low as 25MHz and as high as 500MHz for different applications. These switches offer very low total harmonic distortion and contribute minimal signal distortion in the system. High frequency video can be switched by using these switches with minimal noise. For example a notebook computer with a single video processor and various video sources can use a high frequency switch to select a single video source at a given time. Such video sources include web cam, video graphics engine and web stream etc.

6. Features and Benefits of Digital Switches

High performance bus switches are also offered by NXP in CBT/CBTLV families. These switches can be categorized as digital switches and offer a very high bandwidth with excellent frequency response for high speed designs. Eye diagram is a useful tool to measure the key performance parameters of digital switches. These parameters include rise and fall times, jitter and skew, overshoot and undershoot of signals. System bandwidth can be limited by the frequency response of a switch device and therefore it must be considered carefully during the design. A properly constructed eye diagram shows every possible bit sequence from simple 101's and 010's through to isolated ones after long runs of consecutive zeros and other problem sequences that often show up weaknesses in system design. The loss of information in a signal resulting from limited channel bandwidth of a switch can be observed as timing errors/ jitter in an eye diagram which reduce the width of eye.

Figure 9 shows the reduction in width and opening of eye with respect to a normal eye, as a result of timing errors and additive noise in signal.

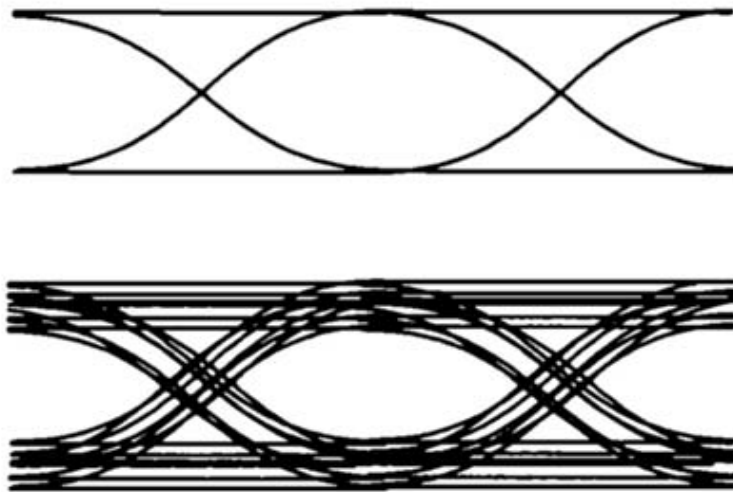

Figure.9 Eye Diagram: Reduction in Width and Opening of Eye

Typically, the frequency response of NXP's CBT switches is limited to 1GHz. In a high speed system, a switch with slower propagation of signals can induce timing errors, source and load reflections, skew between output signals, and changes in rise and fall times. As a result, the system can become unreliable and eventually fail. Therefore, it is important to use the digital switches with optimal propagation delay, and turn on/ off times. CBT switches from NXP can be turned on or off very quickly (~1ns) with minimal propagation delay for switch data (typically sub 1ns). Typical on state resistance for CBT switches is 5 Ohm and input leakage current is limited to ± 1 uA. Additionally, CBT switches are characterized over industrial

temperature range of -40 C to 85 C. Standard SO, SSOP and TSSOP packages are available in CBT switches. The innovative leadless DHVQFN package is also available for select CBT functions, which can save space and cost in design. Built in diode for voltage level shifting, charge pump circuit for hot plugging and undershoot protection are other important features of CBT switches.

7. Applications of Digital Switches

Various uses of CBT switches are realized in high speed microelectronics today. For example, CBT switches can be used to convert the Big Endian data into Little Endian data for storage, particularly when two different types of processors (like Intel's CPU with Little Endian format and Motorola's CPU with Big Endian format) are used in single design, accessing the same memory resources. CBT switches are also popular in automated test equipments (ATE) to select different types of load i.e. resistors and capacitors and test the device I/Os without having to solder and desolder discrete resistors. CBT switches are also used in high density plug in memory cards for personal and industrial computers. By using CBT switches, live insertion of these memory cards with higher storage capacity is realized in systems that cannot be shut down conveniently e.g. airline reservation servers, military communication servers, telecom base stations and switches etc. Another application for these switches is high to low and low to high voltage translation by using current limiting resistors in the design.

CBT switches can also be used in digital display interface of a Notebook PC to switch the control and clock signals of processor between built-in display screen and docking interface for external monitor. Figure 10 shows the application of CBT3306 switch in such a design.

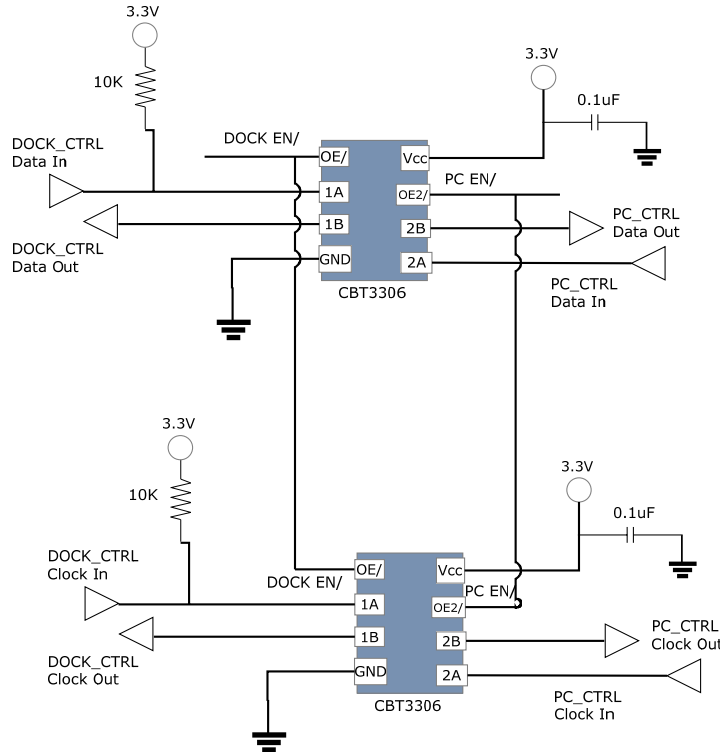

Figure.10 Use of CBT switches in Notebook PC

8. Switch Portfolio

Some of the featured NX3 and LVC analog switches are shown in Table 1. A complete portfolio of NXP’s analog switches can be downloaded from the website. (www.nxp.com/logic)

Part Number	Description	Ron (Typ)	Packages
NX3V1G384GW	Low Ohmic Single Pole Single Throw Normally closed Analog Switch	0.3 Ohm	5 pin PicoGate
NX3V1G384GM			6 pin MicroPak
NX3L1T3157GM	Low Ohmic Single Pole Double Throw Analog Switch with overvoltage tolerant control input	0.5 Ohm	6 pin MicroPak
NX3L1T3157GW			6 pin PicoGate
NX3L4684TK	Dual low voltage, low Ohmic SPDT switch with voltage translation	0.5 Ohm	10 pin HVSON
NX3L4684GM		0.5 Ohm	10 pin XQFN
NX3L2267GM*	Dual low Ohmic Single Pole Double Throw Analog Switch	0.5 Ohm	10 pin XQFN10U
NX3L2467HR*	A Low Ohmic Double Pole Double Throw Analog Switch	0.5 Ohm	16 pin HXQFN16U
74LVC2G53DP	2 Channel Analog MUX/ DeMUX or a single SPDT analog switch	6 Ohm	8 pin TSSOP
74LVC2G53GD			8 pin XSON8U
74LVC2G53GT			8 pin MicroPak
74LVC1G66GW	Single Pole Single Throw Normally Open Analog Switch	6 Ohm	5 pin PicoGate
74LVC1G66GF			6 pin MicroPak

Table 1. Featured NX3 and LVC Analog Switches from NXP

Some featured CBT switches are listed in Table 2 below. Complete portfolio of CBT switches can be downloaded from NXP’s website.

<http://www.standardics.nxp.com/products/cbt/>

Part Number	Description	Vcc	Packages
CBT(D)3306PW	2 Bit switch with two independent channels	4.5V to 5.5V	8 Pin SO
CBT(D)3306D			8 Pin TSSOP
CBTLV1G125GW	1 Bit Switch with rail to rail switch voltage at data I/Os	2.3V to 3.6V	5 Pin PicoGate
CBTLV1G125GM			5 Pin MicroPak
CBT3125DS	4 bit bus switch with 4 independent lines	4.5V to 5.5V	16 pin QSOP
CBT3125PW			14 pin TSSOP
CBT(D)3384DB	10 bit bus switch with 5 bit output enables	4.5V to 5.5V	24 pin SSOP
CBT(D)3384PW			24 pin TSSOP
CBT3257(D)(S)APW	Quad 1:2 MUX/DeMUX	4.5V to 5.5V	16 pin TSSOP
CBT3257(D)(S)ABQ			16 pin DHVQFN
CBT(D)16211DL	24 Bit Bus Switch with 12 bit Output Enables	4.5V to 5.5V	56 pin SSOP
CBT(D)16211DGG			56 pin TSSOP
CBT16292DGG	12-bit 1-of-2 MUX/DeMUX	4.5V to 5.5V	56 pin TSSOP
CBT(D)16212DL	24-Bit Bus Exchange Switch with 12-Bit Output Enables	4.5V to 5.5V	56 pin SSOP
CBT(D)16212DGG			56 pin TSSOP

Table 2. Featured CBT and CBTLV Switches offered by NXP

* NX3L1T66, NX3L2267 and NX3L2467 are currently in development and will be released soon

9. Summary

NXP offers high quality analog and digital switches with different configurations including normally open and normally closed SPST, SPDT and DPDT switches. Low on resistance and flatness, minimal charge injection, low leakage currents, higher isolation, wide signal bandwidth, quick turn on and turn off times and high speed signal propagation are salient features of these switches. Innovative and extremely small Picogate and leadless Micropak packages are available for switch products with high ESD rating, which provides flexibility and reliability in design of portable systems including cell phones, Bluetooth head sets and Notebook personal computers. High frequency response of analog and digital switches results in lossless video data switching in systems with single video processor and various video data sources or displays. CBT switches can be categorized as extremely fast, high frequency digital bus switches. Typically, an eye diagram is used to analyze the key performance parameters of digital switches. These parameters include rise and fall times, jitter and skew, overshoot and undershoot of signals. Built in diode for voltage level shifting, charge pump circuit for hot plugging and undershoot protection circuit result in higher quality and performance of CBT switches. CBT switches are commonly used in memory

interleaving and bus exchange applications in computers. Some of the other applications for CBT switches include conversion of data formats between different processors, access of memory resources in multi-processor or high density multi-memory cards with live insertion capability, flexible test interfaces in automated test equipments, and relays in industrial control systems.

10. References

1. B. Gary, Editorial Director (2005). Analyzing the Signals Using the Eye Diagram. (Article published in High Frequency Design Magazine). Copyrights with Summit Technical Media.
2. “The Anatomy of an Eye Diagram” by SYNTHESYS Research Inc. 2004 -2005 (<http://www.bertscope.com>)
3. MJSQ – Methodologies for Jitter and Signal Quality Specification is a document written as a part of the INCITS project T11.2 (<http://www.t11.org/index.htm>)

11. Legal Information

11.1 Disclaimers

General — Information in this document is believed to be accurate and reliable. However, NXP Semiconductors does not give any representations or warranties, expressed or implied, as to the accuracy or completeness of such information and shall have no liability for the consequences of use of such information.

Right to make changes — NXP Semiconductors reserves the right to make changes to information published in this document, including without limitation specifications and product descriptions, at any time and without notice. This document supersedes and replaces all information supplied prior to the publication hereof.

Suitability for use — NXP Semiconductors products are not designed, authorized or warranted to be suitable for use in medical, military, aircraft, space or life support equipment, nor in applications where failure or malfunction of a NXP Semiconductors product can reasonably be expected to result in personal injury, death or severe property or environmental damage. NXP Semiconductors accepts no liability for inclusion and/or use of NXP Semiconductors products in such equipment or applications and therefore such inclusion and/or use is for the customer's own risk.

Applications — Applications that are described herein for any of these products are for illustrative purposes only. NXP Semiconductors makes no representation or warranty that such applications will be suitable for the specified use without further testing or modification.

Export control — This document as well as the item(s) described herein may be subject to export control regulations. Export might require a prior authorization from national authorities.

11.2 Trademarks

Notice: All referenced brands, product names, service names and trademarks are property of their respective owners.

NXP — is a trademark of NXP B.V.

12. Contents

1.	Introduction	3
2.	Applications in Mobile Phones.....	4
3.	Features and Benefits of Analog Switches	5
4.	Application in Sample and Hold Circuit	8
5.	Frequency Response	9
6.	Features and Benefits of Digital Switches	10
7.	Applications of Digital Switches	11
8.	Switch Portfolio	12
9.	Summary	13
10.	References	14
11.	Legal Information	15
11.1	Disclaimers	15
11.2	Trademarks	15
12.	Contents	16