

SC16IS752/762 Demo Board

User Guide

Hardware Connection

The hardware connection of SC16IS752/762 in Figure 1 shows the jumpers setting on the SC16IS752/762 demo board and how to connect the demo board to the computers with RS-232 cables. The steps how to connect them are described as follows

1. Use a RS-232 Cable such as a 9-pin null modem cable to connect the 9-pin connector on P1 of the demo board to a serial COM port such as COM4 of the computer.
2. Place a jumper to pin 1 and pin 2 on JP2 to select the I2C-bus interface between the host processor and the SC16IS752/762 Bridge IC
3. Set the I2C device address of SC16IS752/762 Bridge IC to 0x9A by shorting pin A0 to VSS on JP3 with a jumper and pin A1 to VSS on JP4 with another jumper.
4. Set the JP16 jumper to the hard reset to allow the S1 push button to reset both the LPC935 microcontroller and the SC16IS752/762 Bridge IC
5. Remove the jumper on JP20
6. Place a jumper to pin 1 and pin 2 on JP8 for the serial loop back communication. The LED on D6 will turn on when power-on
7. Place a jumper on JP17 to use either the external power plugged into the DC power jack on J5 or the battery

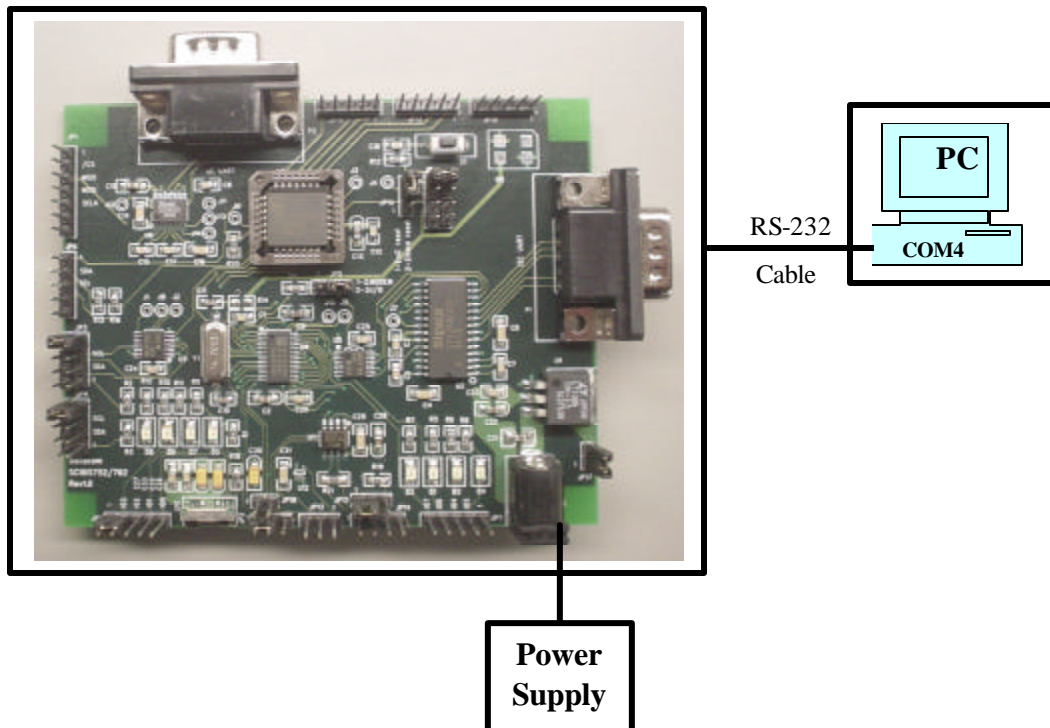

Figure 1. SC16IS752/762 Hardware Connection

Software Connection

Next are the steps how to use the Graphical User Interface (GUI) software in Windows operating system to easily control the SC16IS752/762 demo board from the computer

1. Click on Start -> Programs -> Accessories -> Communications to open a HyperTerminal software in Windows
2. To monitor the serial data being transmitted by the SC16IS752/762 Bridge IC, connect the 9-pin connector (P1) of the SC16IS752/762 demo board to the serial COM port of the computer
3. Configure the terminal to a serial COM port such as COM4 with the setting as follows 115200, 8 bits, no parity, 1 stop bit, and no flow control as shown in Figure 4

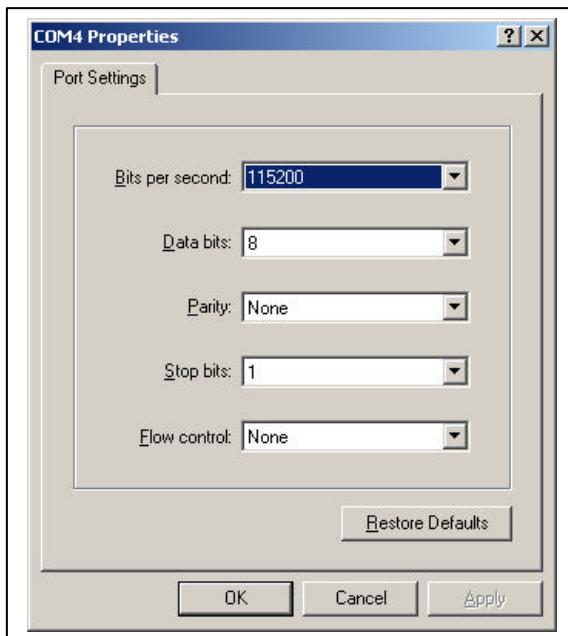

Figure 4. COM4 Properties

4. Select "Call" button to enable the connection of the serial COM4 port. The display of the connection status will be changed from "Disconnected" to "Connected"
5. Now, the COM4 port is established and the I2C-to-UART channel of SC16IS752/762 Bridge IC is ready for serial data transmission.
6. Type any characters in the COM4, the UART channel of SC16IS752/762 Bridge IC will receive them and then transmit them back to the UART channel. For example, type the character 1 in the COM4 and the character 1 will be displayed in the COM4 as result of the character 1 has been looped back from the UART channel as shown in Figure 5

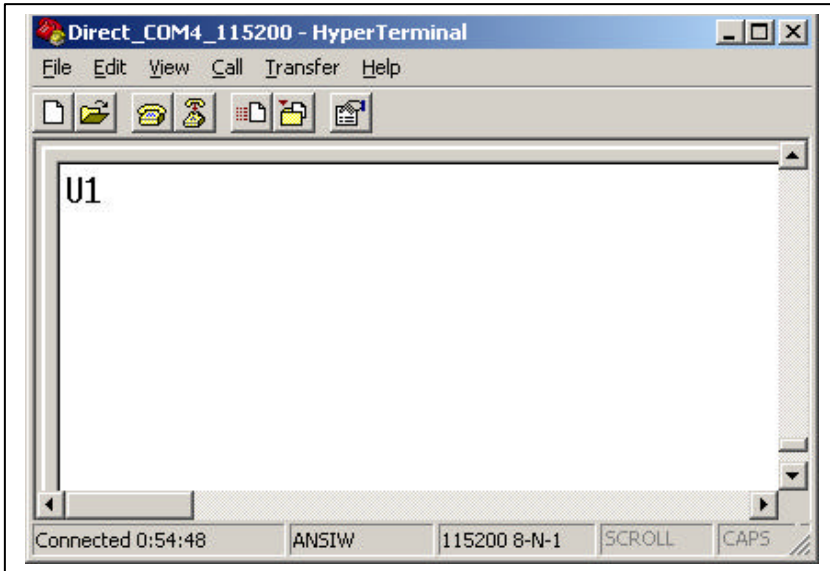

Figure 5. Direct COM4 – HyperTerminal

Application Diagram

The block diagram in Figure 6 shows a host processor with I2C-bus or SPI-bus interface communicating with the SC16IS752/762 Bridge IC to control the peripherals such as modem, PDA, keypad, etc. Using the SC16IS752/762 Bridge IC in the system, the host processor can have IrDA wireless connectivity so the system can communicate with Cell phone, consumer remote controls, and other IrDA wireless devices. To increase design flexibility, the SC16IS752/762 Bridge IC offers up to eight extra GPIO, which can be used for such functions as controlling LEDs or fans, or detecting push buttons or keypads.

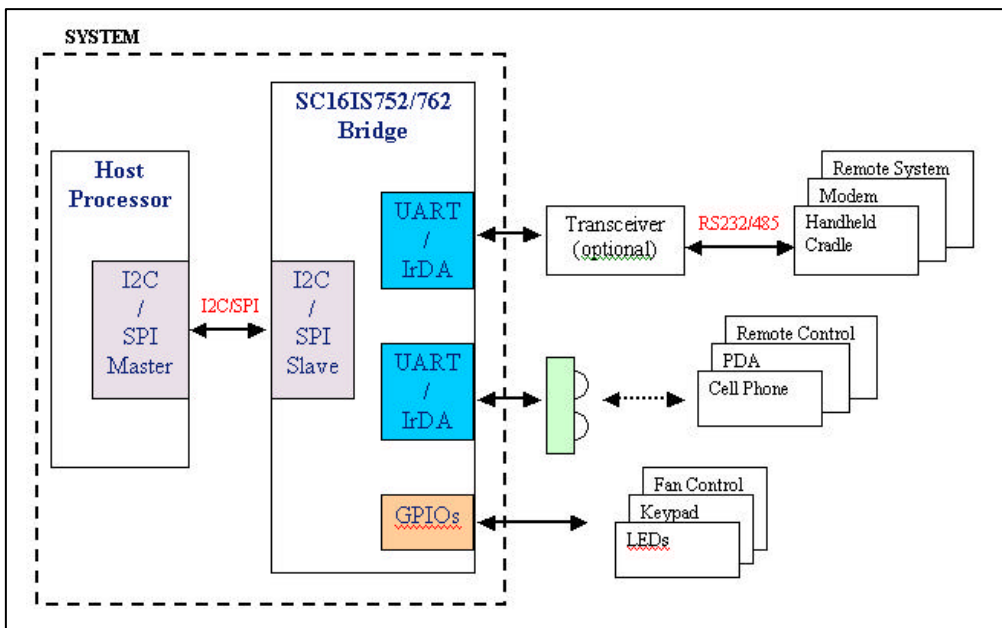

Figure 6. SC16IS752/762 Application Diagram

If an IrDA feature is not enabled or used, the host processor can communicate with the UART devices such as remote system, modem, handheld cradle through RS-232 or RS-485 interface. For designs using RS-485 communication, the UART channel of the SC16IS752/762 Bridge IC features automatic slave address detection, automatic inverted RTS during transmission for enabling the auto-direction functions, and automatic hardware and software flow controls for preventing data overflow or lost.