



# AN10733

Photo flash LED driver

Rev. 01 — 24 February 2009

Application note

## Document information

Info	Content
<b>Keywords</b>	SSL3250A, Photo flash, TX-Masking, 0.5 A load current, soft-start
<b>Abstract</b>	Application guidelines for a photo flash driver for mobile applications, including an application setup.

Revision history

Rev	Date	Description
01	20090224	Application note; initial version

## 1. Introduction

The SSL3250A is an asynchronous boost photo flash dual LED driver for mobile applications. The wide input voltage range and the large maximum output current at a wide output voltage range, insure a lot of implementation possibilities. The high efficiency and soft-start will result in long battery life and low power strain. Many features like overvoltage, overtemperature and feedback shorted protection, undervoltage lockout and time-out functions, protect the battery and LED from overloading, and result in trouble-free operation of the whole mobile application.

## 2. Application Information

### 2.1 General description

The SSL3250A has two general control modes: Direct control and I<sup>2</sup>C control. In Direct control mode the IC is designed to be directly controlled by the application. The I<sup>2</sup>C control is designed to change the timing and current settings of the SSL3250A, although it can also be used to switch the driver to Flash mode, Torch mode or Indicator mode. In Direct control mode, EN1 and EN2 are used. In I<sup>2</sup>C control mode, SCL, SDA and STRB are used. In a typical application only one control mode can be used.

### 2.2 Application diagrams

#### 2.2.1 I<sup>2</sup>C control mode

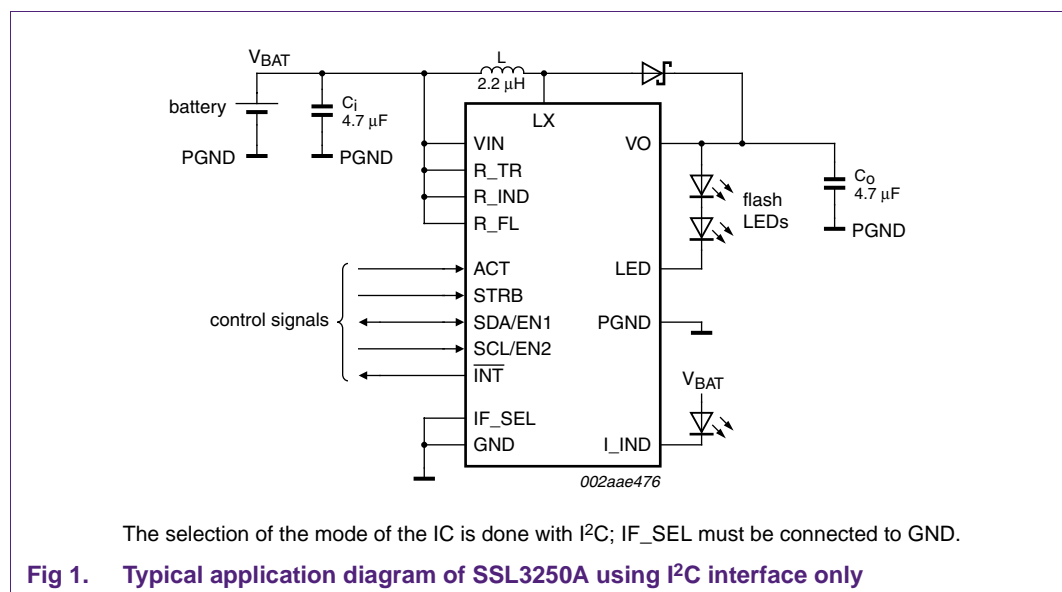

Using the SSL3250A as shown in [Figure 1](#) is the typical application for the SSL3250A in I<sup>2</sup>C control mode, and therefore gives the advantage of maximum flexibility of the operating features of the SSL3250A. Apart from setting the driver into the different operating modes, all of the operating modes can be activated and settings can be altered to match the behavior of the driver to the application, for example, adjusting the LED brightness intensity to meet the required level for a clear picture.

Another important difference is the use of the indicator LED. In I<sup>2</sup>C control mode the indicator LED can be operated almost independently from the main LED. There is only one situation that is common for both the main and the indicator LED and that is in case of a fault condition of the main LED. If a fault condition for the main LED occurs, both the main LED and the indicator LED will switch off. The fault condition for both LEDs is reset by writing all zeros in register 00h.

2.2.2 I<sup>2</sup>C control mode with TX-Masking

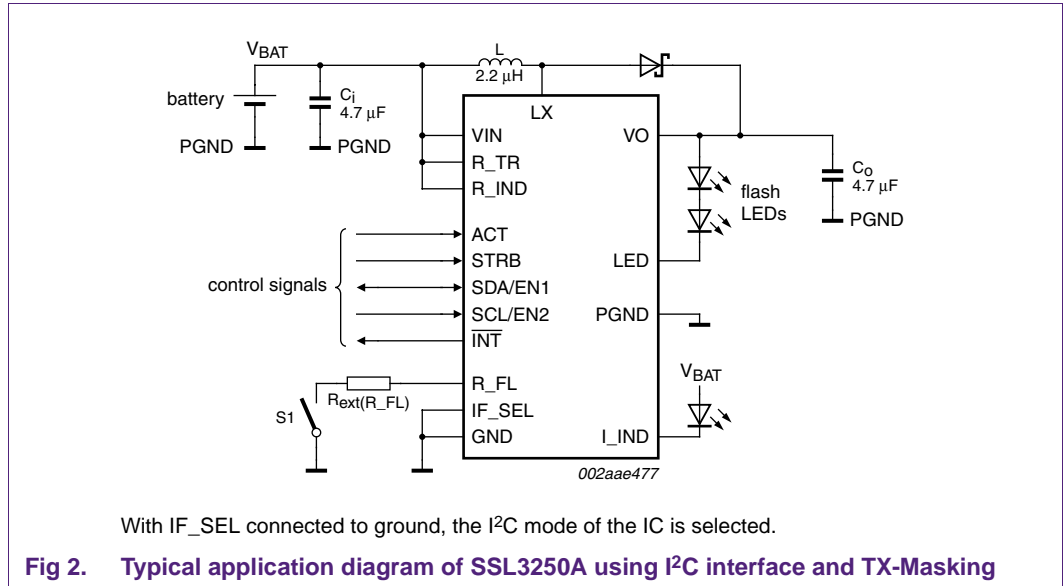

Using the SSL3250A as shown in Figure 2 provides a possibility to reduce the maximum output current of the LED driver in I<sup>2</sup>C mode, without changing the digital value stored in the current control register. This option could be useful in the situation to prevent the driver from using maximum power when the transmitter is being used. An external resistor can be connected to R\_FL to lower the output current to a defined level, which limits the total battery load to an acceptable level.

In I<sup>2</sup>C control mode, resistor R<sub>ext(R\_FL)</sub> will affect both the flash current and the torch current. Both currents will be lowered by the same amount. The formula for calculating R<sub>ext(R\_FL)</sub> is:

$$\frac{(50 \times Reg00 \times 15) + 35}{I_{LED} (mA)} = R_{ext(R_{FL})} (k\Omega) \tag{1}$$

‘Reg00’ is the equivalent decimal value programmed in bits 3 to 7 of the current control register 00h of the SSL3250A. It can have any value from 1 to 31. I<sub>LED</sub> should be chosen to set the maximum main LED current for a given value in register 00h. Example: If Reg00 = 31 the maximum flash current of 500 mA is programmed. When this current should be reduced to a maximum of 250 mA, R<sub>ext(R\_FL)</sub> should have a value of 100 kΩ.

Since Reg00 can have any value from 1 to 31 and the values between 1 and 11 set the torch current, therefore it is also clear why the Torch mode is affected by the resistor R<sub>ext(R\_FL)</sub>.

To enable control of the TX-Mask feature either circuit connection in [Figure 3](#) can be used. In the non-inverted mode a general purpose NPN bipolar transistor is used in a different way. First impression would be that the collector and the emitter are connected wrongly, but they are not. The bipolar transistor is used as a switch and the transistor is driven by a high base current to saturate the transistor. By using the transistor in this way, via its base collector junction, one can calculate that the emitter-collector voltage drop will be much lower and will never exceed more than 10 mV. In this way the influence of the transistor is less than 1 % on the set current.

To turn off the TX-Masking, the voltage on the output of the microcontroller or on the emitter of Q1 in [Figure 3](#) should be higher than 1.25 V and not higher than the supply voltage  $V_{IN}$  of the SSL3250A. It is possible in [Figure 3b](#) to leave the left side  $R_{ext}(R_{FL})$  connected to the emitter of Q1, floating. Leaving one side of  $R_{ext}(R_{FL})$  floating or unconnected is allowed, as it will not affect the normal functionality of the SSL3250A, but is recommended to use a high ohmic resistor to pull it up to a well-defined level, e.g., the supply voltage  $V_{IN}$  of the SSL3250A.

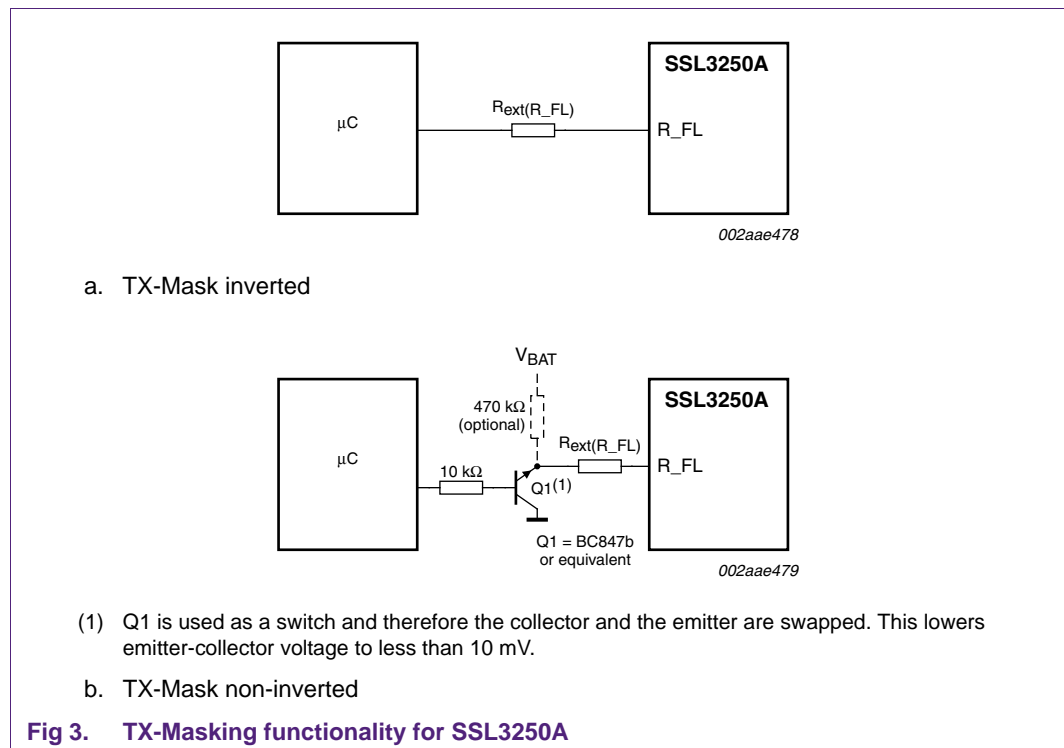

The TX-Mask input could be hardwired to the signal that activates the RF unit. If the RF unit is activated, the SSL3250A should reduce its power usage to make sure the battery is not overloaded. The timing of the SSL3250A has been matched to the general behavior of RF units.

2.2.3 Direct control mode

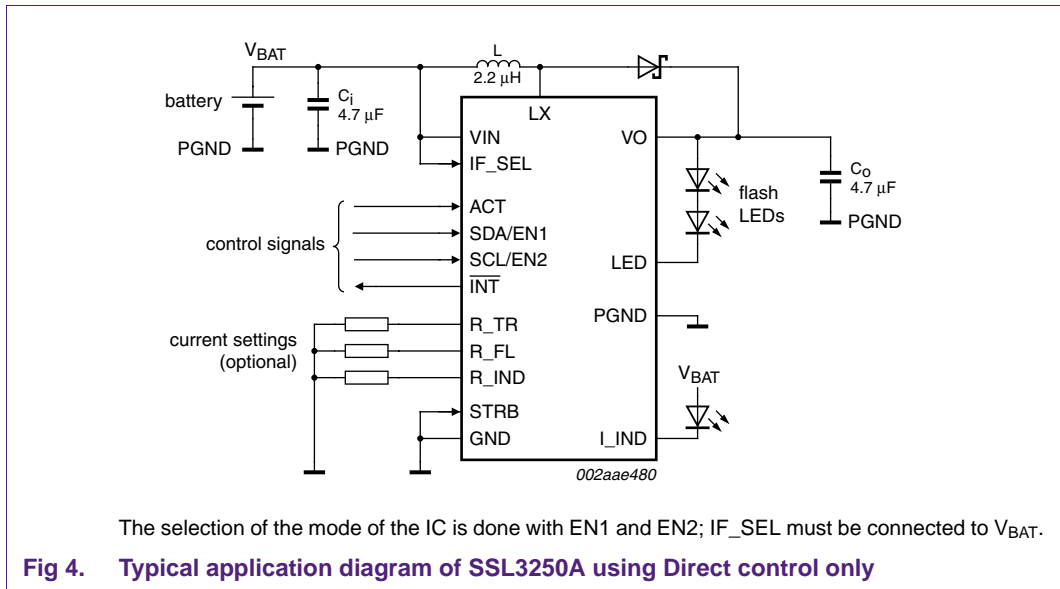

Using the SSL3250A as shown in [Figure 4](#) is the typical application for the SSL3250A in Direct control mode. It has the advantage of operating the driver without using I<sup>2</sup>C communication. This provides a short response time and a less complicated operation, minimizing flash-ON latency. However, it has less flexible control features for the different operating modes, e.g., the main LED and the indicator LED cannot be on at the same time. The Strobe pin (STRB) has no function.

To activate the different modes, Enable1 (EN1) and Enable2 (EN2) must be used while Activate (ACT) remains HIGH. The operating modes are Indicator, Torch and Flash modes. See [Table 1](#).

**Table 1. Enable definition**

ACT	EN2	EN1	Operational mode	LED active
0	X	X	Shutdown mode	-
1	0	0	Standby mode	-
1	0	1	Indicator mode	Indicator LED
1	1	0	Torch mode	Main LED
1	1	1	Flash mode	Main LED

The result is that the driver uses factory default settings as displayed in the SSL3250A data sheet. In Direct control mode, the use of the Timed flash mode is not possible and the maximum flash time is fixed at 820 ms. When the maximum flash time is exceeded, it generates a fault condition, which is signaled by the level of the Interrupt pin (INT) decreasing. This interrupt is automatically cleared when both EN1 and EN2 are set to zero.

The factory default currents and the formulas to adjust the LED currents are listed in [Table 2](#). The LED currents of the main LED and the indicator LED can be changed from the factory defaults (no resistors used), but this requires adding extra resistors. These

currents are fixed for the application. If an external adjustment is not needed, the external resistor pins R\_FL, R\_TR and R\_IND can be left open or floating. This will not affect the operation of the SSL3250A, but it is recommended to connect the unused pins to V<sub>BAT</sub>.

The factory defaults are given in [Table 2](#).

**Table 2. Factory defaults in Direct enable mode**

Operating mode	Factory default value (no resistor)	Adjustable range			Formula to adjust LED current with an external resistor
		Minimum	Preferred minimum	Maximum	
Indicator	10 mA	3.0 mA	3.0 mA	20 mA	$\frac{500}{I_{L\_IND}} = R_{ext(R\_IND)} (k\Omega)$
Torch	125 mA	50 mA	50 mA	200 mA	$\frac{6250}{I_{LED} (torch)} = R_{ext(R\_TR)} (k\Omega)$
Flash	500 mA	70 mA	215 mA	500 mA	$\frac{25000}{I_{LED} (flash)} = R_{ext(R\_FL)} (k\Omega)$

To minimize the amount of digital outputs used, some of the SSL3250A's inputs can be hardwired to signals already used by other parts of the mobile application.

For instance, EN1 and EN2 can be hardwired to the camera module or to the double action shutter button on the application. When the user wants to take a picture he has to press the button halfway. EN2 should be hardwired to the signal that activates the camera, which then also activates the Torch mode. The user can use the Torch mode to focus or to record streaming video. When the user has finished focusing and actually wants to take a picture, he has to press the shutter button fully. This action should also activate EN1 while EN2 is still active. This will activate the Flash mode on the SSL3250A and the 'picture save mode' on the camera module. When the user was recording streaming video he just releases the shutter button to stop recording. This will also deactivate EN1 and EN2 and stop the Flash mode.

## 2.3 PCB design and component placement

The components suitable for this design are listed in [Table 3](#). When designing a PCB layout for the SSL3250A, special attention should be paid to:

- Component placement
- Track width and length
- Usage of vias
- Thermal restrictions

In general, the PCB should be designed to accommodate all components as close as possible to the SSL3250A to minimize track resistance. When connecting capacitors, the GND connection should be as short as possible; as a result, the  $V_{BAT}$  and the VO tracks will be slightly longer. The pin arrangement of the device can make the usage of vias unavoidable. However it is advised, if possible, to avoid the use of vias in tracks to and from those capacitors. If vias are used, use at least 2 or 3 to establish a low ohmic connection.

In order to minimize EMI and to maximize the efficiency, the high current tracks to the coil,  $C_o$  and to the Flash LED should be short and wide, preferred track width is 15 mil per Ampere. If routing to another layer is unavoidable for one of the high current tracks, it is advised to use low ohmic vias and where possible to use two or more vias to lower overall track resistance. In general high-current tracks to and from the same component should run close to each other to minimize the surface of the accompanying current loop. In [Figure 5](#) the main current loops are shown for  $C_i$ , L, D and  $C_o$ . The tracks used for these loops should either be in the same plane close to each other or in different planes on top of each other.

[Figure 5](#) also shows the importance of the position of the output capacitor ( $C_o$ ) and the diode (D). Within every switching cycle, the loop area that carries a large inductor charge and discharge currents change. This change will cause a change in the magnetic field, which will generate currents in other circuits near this loop. Therefore, to keep these induced currents to a minimum,  $C_o$  and the diode (D) must be as close as possible to the SSL3250A.  $C_o$  has a higher priority to be placed close to the driver than  $C_i$ .  $C_i$  can best be placed near the inductor (L). The positive node of  $C_i$  should form a star connection. From this node a separate track should go to the inductor and to VIN of the SSL3250A.

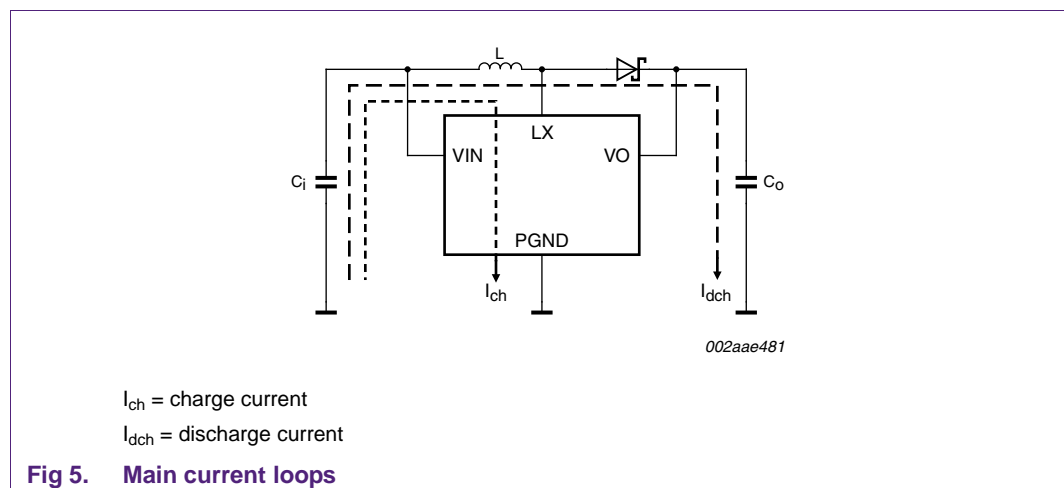

Although the driver has a high efficiency, some heat will be generated. To provide good heat dissipation a good connection from the exposed die pad to the solder pad and to the ground plane in the ground layer underneath has to be provided. This can be achieved by using multiple vias in the exposed die pad.

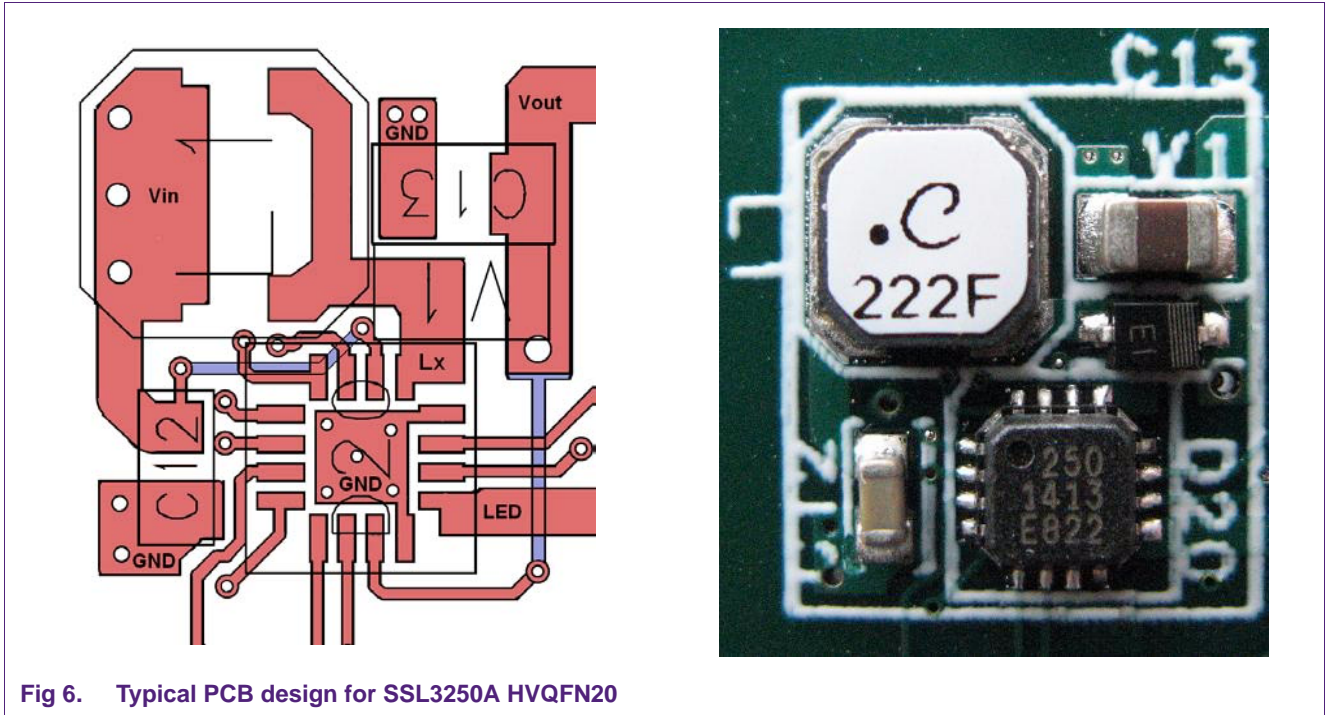

Fig 6. Typical PCB design for SSL3250A HVQFN20

## 2.4 Preferred components

Table 3. Component list

Part	Selection	Value	Case	Size (mm)	Supplier	Type
L	Preferred	2.2 $\mu$ H / 2.3 A / 16 $\Omega$	-	3 × 3 × 1.2	Toko	FDSE0312-2R2M
	Option	2.2 $\mu$ H / 2.5 A / 100 m $\Omega$	-	4 × 4 × 1.2	Coilcraft	LPS4012-222ML
C <sub>i</sub>	Minimum	4.7 $\mu$ F / 6.3 V / X5R	0603	1.75 × 0.95 × 0.95	Murata	GRM188R60J475K
	Preferred	10 $\mu$ F / 6.3 V / X5R	0603	1.75 × 0.95 × 0.95	Murata	GRM188R60J106M
	Option	4.7 $\mu$ F / 10 V / X5R	0603	1.75 × 0.95 × 0.95	Panasonic	ECJ1VB1A475K
	Preferred	10 $\mu$ F / 10 V / X5R	0603	1.75 × 0.95 × 0.95	Panasonic	ECJ1VB0J106M
C <sub>o</sub>	Minimum	4.7 $\mu$ F / 16 V / X5R	0805	2.15 × 1.4 × 1.4	Murata	GRM21BR61C475K
	Preferred	10 $\mu$ F / 16 V / X5R	0805	2.15 × 1.4 × 1.4	Murata	GRM21BR61C106K
	Minimum	10 $\mu$ F / 10 V / X5R	0603	1.75 × 0.95 × 0.95	Panasonic	ECJ2FB1C475K
	Preferred	22 $\mu$ F / 10 V / X5R	0805	2.15 × 1.4 × 1.4	Panasonic	ECJ2FB1A226M
D	Preferred	IF = 2 A max, V <sub>R</sub> = 20 V	SOD323F	1.7 × 1.25 × 0.72	NXP	PMEG2020EJ
	Option	IF ≤ 2 A max, V <sub>R</sub> = 23 V	SOD323	1.65 × 1.25 × 1.0	ST	BAT20J

### 2.4.1 C<sub>i</sub> capacitor

The C<sub>i</sub> capacitor in the typical application serves a double purpose, it is a decoupling capacitor for the internal controller and reference circuits inside the SSL3250A and it is supplying the large input ripple current. For a good input voltage decoupling a low ESR ceramic capacitor is highly recommended. A 4.7  $\mu$ F (X5R/X7R) / 6.3 V is the minimum recommended value. Since the input capacitor is supplying the input ripple current, a larger capacitor will improve the transient behavior of the regulator and the EMI behavior of the power supply. Taking capacitor DC bias and temperature derating specifications into account, a 10  $\mu$ F (X5R/X7R) is preferred. When the physical separation between a contact of C<sub>i</sub> and either supply pin of the SSL3250A becomes more than 5 mm, it is advised to implement extra 100 nF for decoupling of the SSL3250A.

Although the component count will increase, a further improvement is obtained by placing a smaller capacitor of 100 nF (X5R/X7R) parallel to the input capacitor.

When the circuit is used in other than battery powered applications and the input capacitor is located relatively far from the DC buffer capacitors, it is recommended to add a 150  $\mu$ F tantalum or 470  $\mu$ F electrolytic capacitor in parallel to the input capacitor. The ESR of this buffer capacitor is preferably higher as it also dampens the oscillations on the power supply caused by a possible high Q resonant LC circuit formed by the long power lines at the ceramic input capacitor. This electrolytic capacitor is also needed when doing efficiency measurements to obtain a good averaged input current from the supply.

### 2.4.2 C<sub>o</sub> capacitor

C<sub>o</sub> supplies the current in the LED when the SSL3250A is charging energy in the inductor. Although a 4.7  $\mu$ F / 16 V capacitor is sufficient for C<sub>o</sub>, it is advised to use 10  $\mu$ F / 16 V / X5R. The voltage derating characteristics of capacitors show a drop in value near the upper voltage limit of well above 50 %. Therefore a capacitor 4.7  $\mu$ F / 10 V / X5R will not have sufficient capacitance left when operated near the upper voltage limit. A 16 V capacitor, however, will not be operated near its upper voltage limit and therefore it will still have sufficient capacitance. Currently, the smallest available mass production case size for 4.7  $\mu$ F / 16 V / X5R is 0805. To squeeze the maximum out of size

and performance the Panasonic 10  $\mu\text{F}$  / 10 V / X5R is in 0603 case size. Although it will be driven to the maximum operating voltage the capacitance value left is still higher than that of a 4.7  $\mu\text{F}$  type. Another advantage of this capacitor is that the same part can be used as an input and an output capacitor.

### 2.4.3 L inductor

The inductor that has the smallest footprint and has proven to be very suitable for LED flash application (large power for short period) is the Toko FDSE 0312-2R2M. If sustained high output power is of main importance, the Coilcraft LPS4012-222\_L has proven to be a suitable inductor. It has small overall dimensions and a small footprint, but a higher temperature rise current and lower restive losses. Using this coil the SSL3250A would be able to generate a 0.5 A output current continuously. When selecting a suitable inductor, not only the inductance is important, but the saturation current is also an important parameter. It should be matched to the maximum coil peak current, which is set to 2.2 A. Since the coil only carries the large flash current for a short period, the temperature rise current is less important.

### 2.4.4 Diode

Because the SSL3250A is a non-synchronous boost flash LED driver, it requires an external Schottky rectifier diode to conduct the output current to the flash LEDs and the output capacitor. To select a suitable diode, the peak forward current rating of the diode must be equal or greater than the maximum inductor current. The maximum inductor current is limited to 2.2 A by the SSL3250A, so the peak repetitive forward current of the diode should be higher than this value. The diode average forward current must be significantly higher than the flash LED forward current, since the diode also carries the charge current of  $C_o$ . The NXP Semiconductors PMEG2020 is a Schottky barrier diode with a very low forward voltage, and is preferred for the application as the low forward voltage yields a very good efficiency. Although the average forward current is lower, the BAT20J would be a good option in the same size in the typical application. In case the SSL3250A is used at high ambient temperatures and low battery voltages, the average forward current in the diode might exceed this 1 A level and overstress the diode. Sustained stress on the diode can lead to destruction of the diode.

### 2.4.5 Flash LED

The SSL3250A is designed to operate with any LED that can handle large currents in a short period of time provided that the maximum forward voltage of the LED will not exceed 4.5 V at the maximum current of 500 mA or any given current lower than 400 mA. A typical LED would be the LXCL-PWF series from Philips Lumileds. The circuit was tested with the LXCL-PWF3 LED.

### 3. Software examples

#### 3.1 I<sup>2</sup>C control mode: untimed 350 mA flash

In [Table 4](#), the programming sequence is listed for untimed flash of 350 mA using the I<sup>2</sup>C control mode. For repetitive flashes, restart at step 5 for next flash. If Activate (ACT) pin has been reset in between flashes, restart at step 4. The flash strobe pin STRB is level sensitive in untimed mode. This means the time the STRB pin is held HIGH will determine the flash time up to a maximum of 820 ms. If the flash strobe pin STRB is held HIGH or the strobe bit in register 02h is set HIGH for a longer period than 820 ms, the time-out protection of the SSL3250A will be triggered and the INT pin will go LOW indicating a fault condition.

Reading the status register in step 6 may be omitted, but could be done to check for any problems of the driver like, shorted or open LED pin, operating temperature that is too high and flash time-out of the SSL3250A. Any fault condition will be flagged by the INT pin of the SSL3250A going LOW. Programming '00' in register 00h resets all error conditions and clears the INT flag, therefore the status register 03h has to be read first before register 00h is cleared by programming '00' to it.

**Table 4. Initialization for 350 mA flash**

Step	Action	Terminal	State	I <sup>2</sup> C commandAdr / reg / data (hex)	Comment
1	Apply power	VIN	> 2.7 V	-	V <sub>DD</sub> = 3.6 V typical
2	Initialize digital lines	IF_SEL	LOW	-	-
		STRB	LOW	-	-
		ACT	LOW	-	-
3	Activate device	ACT	HIGH	-	Turn on SSL3250A
4	Init device	SDA/SCL	write	30 00 00	Clear fault register; all LEDs off
				30 01 00	Timed mode off
				30 02 00	Flash strobe off
5	Set main LED flash current level	SDA/SCL	write	30 00 A8	Set flash current to 350 mA
6	Start condition (level sensitive)				
	preferred	STRB	HIGH	-	Keep STRB line HIGH for < 820 ms
	with I <sup>2</sup> C strobe latency	SDA/SCL	write	30 02 01	Set STRB bit HIGH for < 820 ms
	preferred	STRB	LOW	-	STRB line LOW
7	Read status register (not mandatory)	SDA/SCL	read	31 03 01	Get status from device
				31 03 01	Get status from device
8	Clear fault register	SDA/SCL	write	30 00 00	Clear status register; all LEDs off

### 3.2 I<sup>2</sup>C control mode: 492 ms timed flash 350 mA

The timed mode set-up of the SSL3250A is almost the same as the untimed mode. Only steps 4 and 6 are different. When step 4 and step 6 in [Table 4](#) are replaced by step 4 and step 6 listed in [Table 5](#), the SSL3250A will operate in timed mode.

In timed mode, the flash strobe pin STRB becomes positive edge sensitive. This means the time the STRB pin is held HIGH, or the time the STRB bit in register 02h is set HIGH will not influence the set flash time of 492 ms as set in step 4 of the example in [Table 5](#).

Once the timed mode is set, the SSL3250A will be triggered by a LOW-to-HIGH state change on the STRB pin or a 0-to-1 change in register 02h, even when the current in the current control register 00h is set to logic 0. If the current is 0 and the strobe is triggered, but the internal timer will not start before a flash current is programmed in the current control register. Once a valid current is programmed, the flash will state immediately because the strobe was already triggered.

In timed mode the  $\overline{\text{INT}}$  pin will not go LOW at the end of the timed period, indicating a time-out, not even if the time is set to the maximum time-out time of 820 ms.

**Table 5. Initialization for 350 mA timed flash using external strobe**

Step	Action	Terminal	State	I <sup>2</sup> C commandAdr / reg / data (hex)	Comment
4	Init device	SDA/SCL	write	30 00 00	Clear fault register; all LEDs off
				30 01 16	Timed mode ON, set flash time to 492 ms
				30 02 00	Flash strobe off
6	Start condition (edge sensitive)				
	Preferred	STRB	HIGH	-	Short positive pulse (1 $\mu$ s) on STRB
	with I <sup>2</sup> C strobe latency	SDA/SCL	write	30 02 01	Set STRB bit HIGH for 1 ms
	Preferred	STRB	LOW	-	STRB line LOW
	with I <sup>2</sup> C strobe latency	SDA/SCL	write	30 02 00	Set STRB bit LOW

### 3.3 I<sup>2</sup>C control mode: 125 mA Torch mode

The Torch mode set-up of the SSL3250A has the same initialization steps 1 to 4 as the flash in untimed mode set-up ([Table 4](#)). Again, only step 5 in [Table 6](#) below is needed to turn on the main LEDs in Torch mode. Reading the status register in step 6 may be omitted, but can be done to check any problems of the drive, like a shorted or open LED pin or an SSL3250A temperature being too high. Any fault condition will be flagged by the INT pin of the SSL3250A going LOW. Programming 00 in register 00h resets the error condition and clears the INT flag. Therefore, the status register 03h has to be read first before the register 00h is programmed to turning the Torch mode to all zero.

**Table 6. Initialization for 125 mA torch**

Step	Action	Terminal	State	I <sup>2</sup> C commandAdr / reg / data (hex)	Comment
5	Set main LED torch current level	SDA/SCL	write	30 00 30	Set torch current to 125 mA and turns on main LED
6	Read status register (not mandatory)	SDA/SCL	read	31 03 01	Get status from device check shorted or open LED connection.
7	Turn off Torch mode and clear fault register	SDA/SCL	write	30 00 00	Clear fault register; all LEDs off

### 3.4 I<sup>2</sup>C control mode: flash from Torch mode

In both timed and untimed mode, it is possible to directly flash from Torch mode. The Torch mode in this case can be used to properly focus the camera in low light environments. The drawback in flashing from Torch mode is that the STRB signal (either hardware or software) cannot be used to trigger the flash. The start of flash is only possible by programming a flash current value into the current control register **after** the STRB line or bit is asserted. Therefore, there will be some software delay before the Flash mode will start. The extra software propagation delay will be 300 μs when using a 100 kHz I<sup>2</sup>C-bus frequency. The time from sending the command to full flash will be less than 1 ms.

The flash can be turned off again by setting the STRB line LOW or programming the STRB bit to 0. Keep in mind that when the flash is turned off by programming the current in the current control register 00h to '00', the maximum flash ON period needs to be shortened by the propagation delay of the I<sup>2</sup>C command flash OFF. This delay is typically less than 0.5 ms using a 100 kHz I<sup>2</sup>C-bus frequency. Although the flash period is triggered by the strobe signal or command, the time-out timer will not start until a flash current level is programmed in current control register 00h.

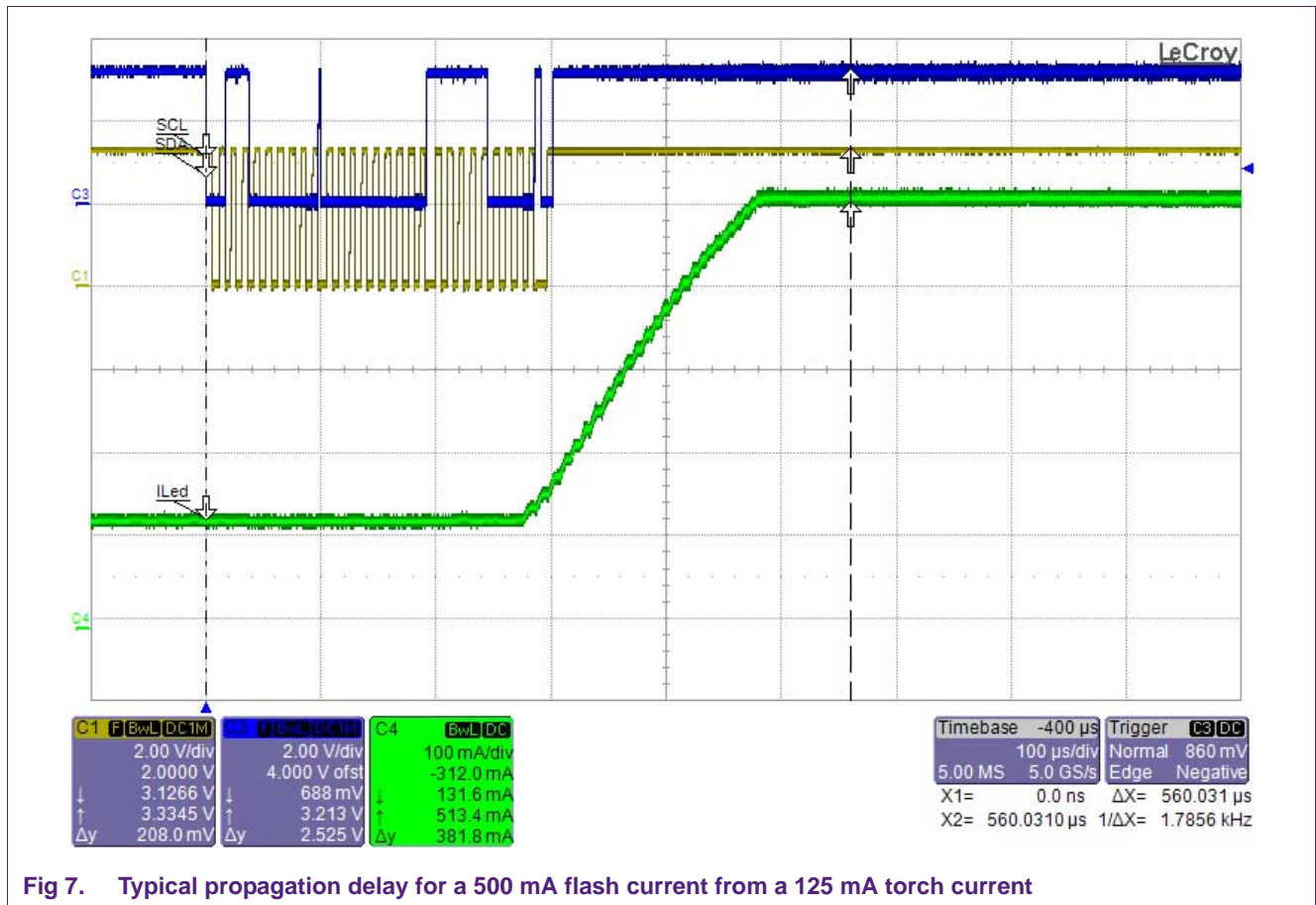

Fig 7. Typical propagation delay for a 500 mA flash current from a 125 mA torch current

The flash after Torch mode setup of the SSL3250A has the same initialization step 1 to step 4 as the flash in Untimed mode setup in [Table 4](#). Again, only step 5 in [Table 7](#) below is needed to turn on the main LEDs in Torch mode. Reading the status register in step 9 may be omitted, but can be done to check any problems of the drive, like a shorted or open LED pin or an SSL3250A temperature being too high. Any fault condition will be flagged by the INT pin of the SSL3250A going LOW. Programming 00 in register 00h resets the error condition and clears the INT flag. Therefore, the status register 03h has to be read first before the register 00h is programmed to turning the Torch mode to all zero.

**Table 7. Initialization for 350 mA flash from 125 mA torch**

Step	Action	Terminal	State	I <sup>2</sup> C commandAdr / reg / data (hex)	Comment
5	Set main LED torch current level	SDA/SCL	write	30 00 30	Set torch current to 125 mA and turns on main LED
6	Start condition (level sensitive)				
	Preferred	STRB	HIGH	-	Keep STRB line HIGH
	with I <sup>2</sup> C strobe latency	SDA/SCL	write	30 02 01	Set STRB bit HIGH
7	Set main LED flash current level	SDA/SCL	write	30 00 A8	Set flash current to 350 mA <b>and immediately triggers the flash once programmed</b>
8	Stop condition (level sensitive)				
	Preferred	STRB	LOW	-	STRB line LOW < (820 ms – propagation delay between step 6 and step 7)
	with I <sup>2</sup> C strobe latency	SDA/SCL	write	30 02 01	Set STRB bit LOW < (820 ms – propagation delay between step 6 and step 7)
9	Read status register (not mandatory)	SDA/SCL	read	31 03 01	Get status from device check shorted or open LED connection
10	Turn off Torch mode and clear fault register	SDA/SCL	write	30 00 00	Clear fault register; all LEDs off

### 3.5 Direct control mode: untimed 500 mA flash

In Direct control mode, only the control lines EN1 and EN2 control the state of the SSL3250A. The STRB pin has no function. For repetitive flashes, repeat steps 5 and 6. Any fault condition in Direct control mode will still be flagged by the INT pin of the SSL3250A going LOW, but since I<sup>2</sup>C communication is not possible the cause of the interrupt cannot be determined. The INT pin will only signal that there was a problem in the driver, like a shorted or open LED pin, a temperature that is too high or a flash time-out of the SSL3250A.

**Table 8. Initialization for a direct controlled 500 mA flash**

Step	Action	Terminal	State	I <sup>2</sup> C commandAdr / reg / data (hex)	Comment
1	Apply power	VIN	> 2.7 V	-	V <sub>DD</sub> = 3.6 V typical
2	Initialize digital lines	IF_SEL	HIGH	-	-
		STRB	LOW	-	Pin has no function in direct control mode
		ACT	LOW	-	-
3	Clear	EN1	LOW	-	Clear fault register; all LEDs off
		EN2	LOW	-	-
4	Activate device	ACT	HIGH	-	Turn on SSL3250A
5	Flash ON	EN1	HIGH	-	Turn on Main LED(s) Flash current set by R <sub>FL</sub> ; if R <sub>FL</sub> = ∞, then flash current = 500 mA
		EN2	LOW	-	-
6	Flash OFF	EN1	LOW	-	turn off Main LED(s) and clear fault register
		EN2	LOW	-	-

## 4. Abbreviations

**Table 9. Abbreviations**

Acronym	Description
EMI	ElectroMagnetic Interference
ESR	Equivalent Series Resistance
I <sup>2</sup> C-bus	Inter Integrated Circuit bus
IC	Integrated Circuit
LC	inductor-capacitor filter
LED	Light-Emitting Diode
PCB	Printed-Circuit Board
RF	Radio Frequency

## 5. Legal information

---

### 5.1 Definitions

**Draft** — The document is a draft version only. The content is still under internal review and subject to formal approval, which may result in modifications or additions. NXP Semiconductors does not give any representations or warranties as to the accuracy or completeness of information included herein and shall have no liability for the consequences of use of such information.

### 5.2 Disclaimers

**General** — Information in this document is believed to be accurate and reliable. However, NXP Semiconductors does not give any representations or warranties, expressed or implied, as to the accuracy or completeness of such information and shall have no liability for the consequences of use of such information.

**Right to make changes** — NXP Semiconductors reserves the right to make changes to information published in this document, including without limitation specifications and product descriptions, at any time and without notice. This document supersedes and replaces all information supplied prior to the publication hereof.

**Suitability for use** — NXP Semiconductors products are not designed, authorized or warranted to be suitable for use in medical, military, aircraft, space or life support equipment, nor in applications where failure or malfunction of a NXP Semiconductors product can reasonably be expected to result in personal injury, death or severe property or environmental damage. NXP Semiconductors accepts no liability for inclusion and/or use of NXP Semiconductors products in such equipment or applications and therefore such inclusion and/or use is at the customer's own risk.

**Applications** — Applications that are described herein for any of these products are for illustrative purposes only. NXP Semiconductors makes no representation or warranty that such applications will be suitable for the specified use without further testing or modification.

### 5.3 Trademarks

Notice: All referenced brands, product names, service names and trademarks are the property of their respective owners.

**I<sup>2</sup>C-bus** — logo is a trademark of NXP B.V.

## 6. Contents

---

<b>1</b>	<b>Introduction</b> .....	<b>3</b>
<b>2</b>	<b>Application Information</b> .....	<b>3</b>
2.1	General description .....	3
2.2	Application diagrams .....	3
2.2.1	I <sup>2</sup> C control mode .....	3
2.2.2	I <sup>2</sup> C control mode with TX-Masking .....	4
2.2.3	Direct control mode .....	6
2.3	PCB design and component placement .....	8
2.4	Preferred components .....	10
2.4.1	C <sub>i</sub> capacitor .....	10
2.4.2	C <sub>o</sub> capacitor .....	10
2.4.3	L inductor .....	11
2.4.4	Diode .....	11
2.4.5	Flash LED .....	11
<b>3</b>	<b>Software examples</b> .....	<b>12</b>
3.1	I <sup>2</sup> C control mode: untimed 350 mA flash .....	12
3.2	I <sup>2</sup> C control mode: 492 ms timed flash 350 mA .....	13
3.3	I <sup>2</sup> C control mode: 125 mA Torch mode .....	13
3.4	I <sup>2</sup> C control mode: flash from Torch mode .....	14
3.5	Direct control mode: untimed 500 mA flash ..	16
<b>4</b>	<b>Abbreviations</b> .....	<b>16</b>
<b>5</b>	<b>Legal information</b> .....	<b>17</b>
5.1	Definitions .....	17
5.2	Disclaimers .....	17
5.3	Trademarks .....	17
<b>6</b>	<b>Contents</b> .....	<b>18</b>

Please be aware that important notices concerning this document and the product(s) described herein, have been included in section 'Legal information'.



© NXP B.V. 2009.

All rights reserved.

For more information, please visit: <http://www.nxp.com>

For sales office addresses, please send an email to: [salesaddresses@nxp.com](mailto:salesaddresses@nxp.com)

Date of release: 24 February 2009

Document identifier: AN10733\_1