

DATA SHEET



PCA9511

Level shifting hot swappable I²C-bus
and SMBus buffer

Product data sheet
Supersedes data of 2004 Oct 05

2009 May 08

Level shifting hot swappable I²C-bus and SMBus buffer

PCA9512

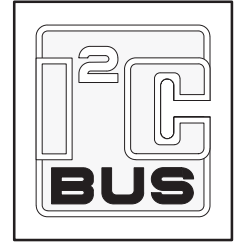

DESCRIPTION

The PCA9512 is a hot swappable I²C and SMBus buffer that allows I/O card insertion into a live backplane without corruption of the data and clock buses and includes two dedicated supply voltage pins to provide level shifting between 3.3 V and 5 V systems while maintaining the best noise margin for each voltage level. Either pin may be powered with supply voltages ranging from 2.7 V to 5.5 V with no constraints on which supply voltage is higher. Control circuitry prevents the backplane from being connected to the card until a stop bit or bus idle occurs on the backplane without bus contention on the card. When the connection is made, the PCA9512 provides bi-directional buffering, keeping the backplane and card capacitances isolated.

The dynamic offset design of the PCA9510/11/12/13/14 I/O drivers allow them to be connected to another PCA9510/11/12/13/14 device in series or in parallel and to the A side of the PCA9517. The PCA9510/11/12/13/14 can **not** connect to the static offset I/Os used on the PCA9515/15A/16/16A/17 B side and PCA9518.

FEATURES

- Bi-directional buffer for SDA and SCL lines increases fanout and prevents SDA and SCL corruption during live board insertion and removal from multi-point backplane systems
- Compatible with I²C standard mode, I²C fast mode, and SMBus standards
- $\Delta V/\Delta t$ rise time accelerators on all SDA and SCL lines with ability to disable $\Delta V/\Delta t$ rise time accelerators through the ACC pin for lightly loaded systems
- Rise time accelerator requires the pull-up voltage and respective V_{DD} to be supplied by the same voltage
- 5 V to 3.3 V level translation with optimum noise margin
- High-impedance SDA, SCL pins for V_{CC} or $V_{CC2} = 0$ V
- 1 V precharge on all SDA and SCL lines
- Supports clock stretching and multiple master arbitration/synchronization
- Operating power supply voltage range: 2.7 V to 5.5 V
- 0 kHz to 400 kHz clock frequency
- ESD protection exceeds 2000 V HBM per JESD22-A114, 200 V MM per JESD22-A115 and 1000 V CDM per JESD22-C101
- Latch-up testing is done to JESDEC Standard JESD78 which exceeds 100 mA
- Packages offered: SO8, TSSOP8 (MSOP8)

APPLICATION

- cPCI, VME, AdvancedTCA cards and other multi-point backplane cards that are required to be inserted or removed from an operating system.

ORDERING INFORMATION

PACKAGES	TEMPERATURE RANGE	ORDER CODE	TOPSIDE MARK	DRAWING NUMBER
8-pin plastic SO	-40 °C to +85 °C	PCA9512D	PCA9512	SOT96-1
8-pin plastic TSSOP (MSOP)	-40 °C to +85 °C	PCA9512DP	9512	SOT505-1

Standard packing quantities and other packaging data are available at www.standardics.nxp.com/packaging/.

PIN CONFIGURATION

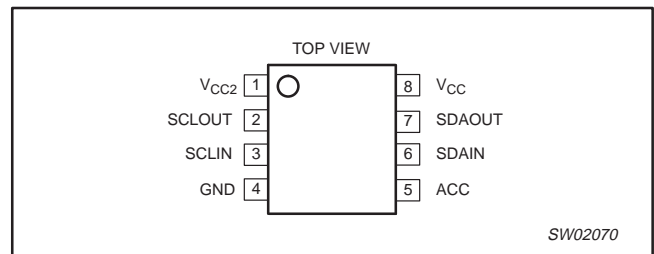

Figure 1. Pin configuration.

PIN DESCRIPTION

PIN	SYMBOL	DESCRIPTION
1	V _{CC2}	Supply voltage for devices on the card I ² C-buses. Connect pull-up resistors from SDAOUT and SCLOUT to this pin.
2	SCLOUT	Serial clock output to and from the SCL bus on the card.
3	SCLIN	Serial clock input to and from the SCL bus on the backplane.
4	GND	Ground. Connect this pin to a ground plane for best results.
5	ACC	CMOS threshold digital input pin that enables and disables the rise-time accelerators on all four SDA and SCL pins. ACC enables all accelerators when set to V _{CC2} , and turns them off when set to GND.
6	SDAIN	Serial data input to and from the SDA bus on the backplane/long distance bus.
7	SDAOUT	Serial data output to and from the SDA bus on the card.
8	V _{CC}	Power supply. From the backplane, connect pull-up resistors from SDAIN and SCLIN to this pin.

Level shifting hot swappable I²C-bus and SMBus buffer

PCA9512

TYPICAL APPLICATION

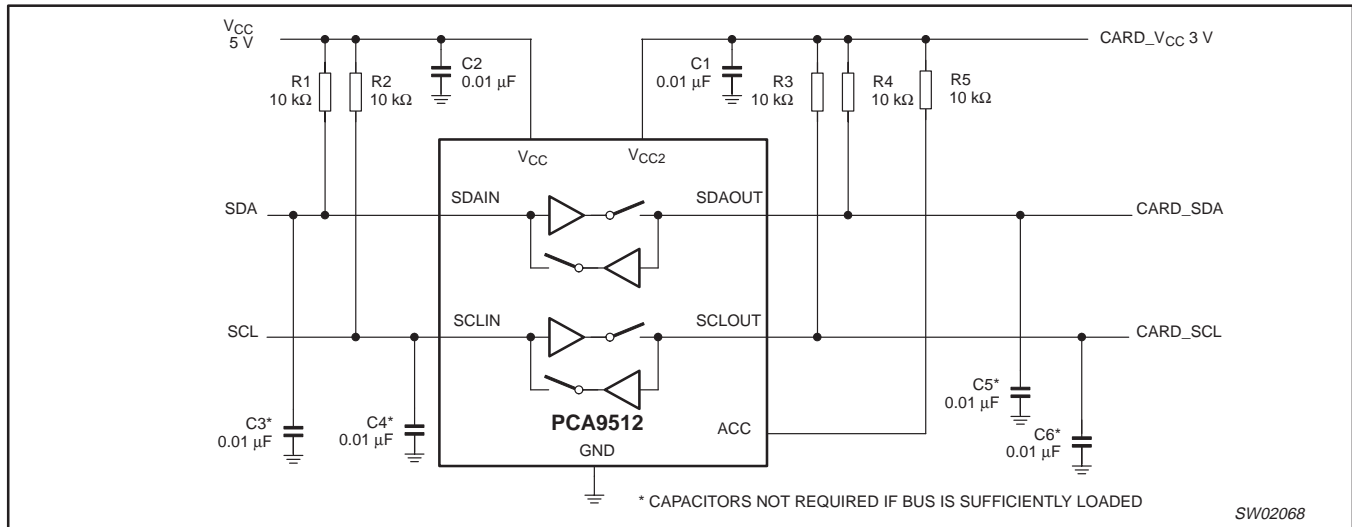

Figure 2. Typical application

BLOCK DIAGRAM

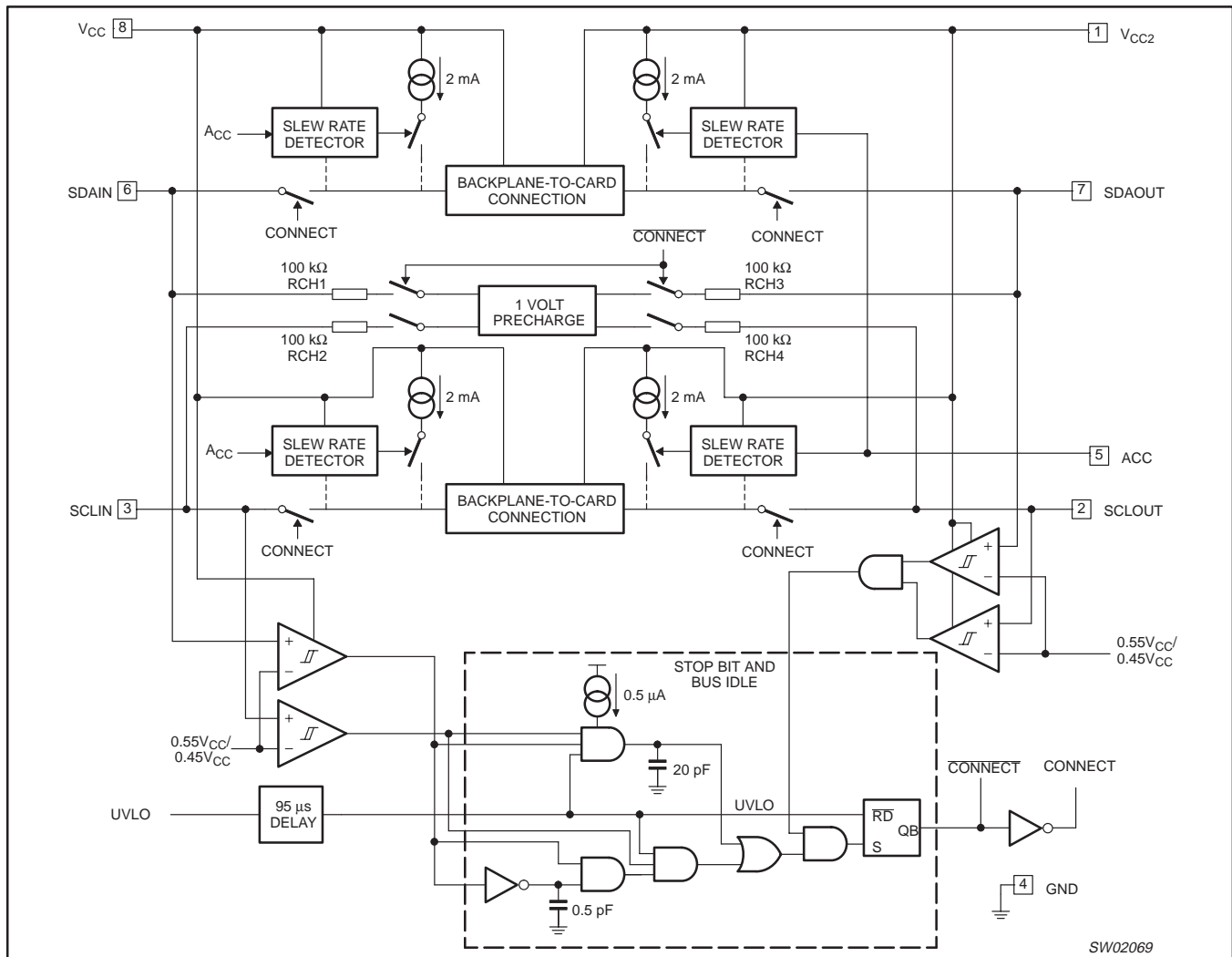

Figure 3. Block diagram.

Level shifting hot swappable I²C-bus and SMBus buffer

PCA9512

FEATURE SELECTION CHART

FEATURES	PCA9510	PCA9511	PCA9512	PCA9513	PCA9514
Idle detect	Yes	Yes	Yes	Yes	Yes
High impedance SDA, SCL pins for $V_{CC} = 0\text{ V}$	Yes	Yes	Yes	Yes	Yes
Rise time accelerator circuitry on all SDA and SCL lines	—	Yes	Yes	Yes	Yes
Rise time accelerator circuitry hardware disable pin for lightly loaded systems	—	—	Yes	—	—
Rise time accelerator threshold 0.8 V vs 0.6 V improves noise margin	—	—	—	Yes	Yes
Ready open drain output	Yes	Yes	—	Yes	Yes
Two V_{CC} pins to support 5 V to 3.3 V level translation with improved noise margins	—	—	Yes	—	—
1 V precharge on all SDA and SCL lines	IN only	Yes	Yes	—	—
92 μA current source on SCLIN and SDAIN for PICMG applications	—	—	—	Yes	—

OPERATION

Start-up

When the PCA9512 is powered up either V_{CC} or V_{CC2} may rise first and either may be more positive or they may be equal, however the PCA9512 will not leave the under voltage lock out/initialization state until both V_{CC} and V_{CC2} have gone above 2.5 V. If either V_{CC} or V_{CC2} drops below 2.0 V it will return to the under voltage lock out/initialization state. In the under voltage lock out state the connection circuitry is disabled, the rise time accelerators are disabled, and the precharge circuitry is also disabled. After both V_{CC} and V_{CC2} are valid, independent of which is higher, the PCA9512 enters the initialization state, during this state the 1 V precharge circuitry is activated and pulls up the SDA and SCL pins to 1 V through individual 100 k Ω nominal resistors. At the end of the initialization state the "Stop Bit And Bus Idle" detect circuit is enabled. When all the SDA and SCL pins have been HIGH for the bus idle time or when all pins are HIGH and a stop condition is seen on the SDAIN and SCLIN pins, the connect circuitry is activated, connecting SDAIN to SDAOUT and SCLIN to SCLOUT. The 1 V precharge circuitry is disabled when the connection is made, unless the ACC pin is LOW, the rise time accelerators are enabled at this time also.

Connection Circuitry

Once the connection circuitry is activated, the behavior of SDAIN and SDAOUT as well as SCLIN and SCLOUT become identical with each acting as a bidirectional buffer that isolated the input bus capacitance from the output bus capacitance while communicating the logic levels. If $V_{CC} \neq V_{CC2}$, then a level shifting function is also performed between input and output. A LOW forced on either SDAIN or SDAOUT will cause the other pin to be driven LOW by the

PCA9512. The same is also true for the SCL pins. Noise between $0.7V_{CC}$ and V_{CC} on the SDAIN and SCLIN pins and $0.7V_{CC2}$ and V_{CC2} on the SDAOUT and SCLOUT pins is generally ignored because a falling edge is only recognized when it falls below the $0.7V_{CC}$ for SDAIN and SCLIN (or $0.7V_{CC2}$ for SDAOUT and SCLOUT pins) with a slew rate of at least 1.25 V/ μs . When a falling edge is seen on one pin the other pin in the pair turns on a pull down driver that is reference to a small voltage above the falling pin. The driver will pull the pin down at a slow rate determined by the driver and the load. The first falling pin may have a fast or slow slew rate, if it is faster than the pull down slew rate then the initial pull down rate will continue until it is LOW. If the first falling pin has a slow slew rate then the second pin will be pulled down at its initial slew rate only until it is just above the first pin voltage then they will both continue down at the slew rate of the first. Once both sides are LOW they will remain LOW until all the external drivers have stopped driving LOWs. If both sides are being driven LOW to the same or nearly the same value by external drivers, which is the case for clock stretching and is typically the case for acknowledge, and one side external driver stops driving, that pin will rise and rise above the nominal offset voltage until the internal driver catches up and pulls it back down to the offset voltage. This bounce is worst for low capacitances and low resistances, and may become excessive. When the last external driver stops driving a LOW, that pin will bounce up and settle out just above the other pin as both rise together with a slew rate determined by the internal slew rate control and the RC time constant. As long as the slew rate is at least 1.25 V/ μs , when the pin voltage exceed 0.6 V the rise time accelerator circuits are turned on and the pull down driver is turned off. If the ACC pin is LOW the rise time accelerator circuits will be disabled but the pull down driver will still turn off.

Level shifting hot swappable I²C-bus and SMBus buffer

PCA9512

Maximum number of devices in series

Each buffer adds about 0.065 V dynamic level offset at 25 °C with the offset larger at higher temperatures. Maximum offset (V_{OS}) is 0.150 V. The LOW level at the signal origination end (master) is dependent upon the load and the only specification point is the I²C-bus specification of 3 mA will produce $V_{OL} < 0.4$ V, although if lightly loaded the V_{OL} may be ~ 0.1 V. Assuming $V_{OL} = 0.1$ V and $V_{OS} = 0.1$ V, the level after four buffers would be 0.5 V, which is only about 0.1 V below the threshold of the rising edge accelerator (about 0.6 V). With great care a system with four buffers may work, but as the V_{OL} moves up from 0.1 V, noise or bounces on the line will result in firing the rising edge accelerator thus introducing false clock edges. Generally it is recommended to limit the number of buffers in series to two.

The PCA9510 (rise time accelerator is permanently disabled) and the PCA9512 (rise time accelerator can be turned off) are a little different with the rise time accelerator turned off because the rise time accelerator will not pull the node up, but the same logic that turns on the accelerator turns the pull-down off. If the V_{IL} is above ~ 0.6 V and a rising edge is detected, the pull-down will turn off and will not turn back on until a falling edge is detected; so if the noise is small enough it may be possible to use more than two PCA9510 or PCA9512 parts in series but is not recommended.

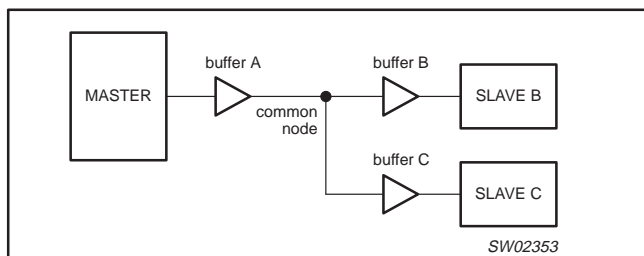

Figure 4.

Consider a system with three buffers connected to a common node and communication between the Master and Slave B that are connected at either end of Buffer A and Buffer B in series as shown in Figure 4. Consider if the V_{OL} at the input of Buffer A is 0.3 V and the V_{OL} of Slave B (when acknowledging) is 0.4 V with the direction changing from Master to Slave B and then from Slave B to Master. Before the direction change you would observe V_{IL} at the input of Buffer A of 0.3 V and its output, the common node, is ~ 0.4 V. The output of Buffer B and Buffer C would be ~ 0.5 V, but Slave B is driving 0.4 V, so the voltage at Slave B is 0.4 V. The output of Buffer C is ~ 0.5 V. When the Master pull-down turns off, the input of Buffer A rises and so does its output, the common node, because it

is the only part driving the node. The common node will rise to 0.5 V before Buffer B's output turns on, if the pull-up is strong the node will bounce. If the bounce goes above the threshold for the rising edge accelerator ~ 0.6 V the accelerators on both Buffer A and Buffer C will fire contending with the output of Buffer B. The node on the input of Buffer A will go HIGH as will the input node of Buffer C. After the common node voltage is stable for a while the rising edge accelerators will turn off and the common node will return to ~ 0.5 V because the Buffer B is still on. The voltage at both the Master and Slave C nodes would then fall to ~ 0.6 V until Slave B turned off. This would not cause a failure on the data line as long as the return to 0.5 V on the common node (~ 0.6 V at the Master and Slave C) occurred before the data setup time. If this were the SCL line, the parts on Buffer A and Buffer C would see a false clock rather than a stretched clock, which would cause a system error.

Propagation Delays

The delay for a rising edge is determined by the combined pull-up current from the bus resistors and the PCA9512 and the effective capacitance on the lines. If the pull-up currents are the same, any difference in capacitance between the two sides. The t_{PLH} may be negative if the output capacitance is less than the input capacitance and would be positive if the output capacitance is larger than the input capacitance, when the currents are the same.

The t_{PHL} can never be negative because the output does not start to fall until the input is below $0.7V_{CC}$ (or $0.7V_{CC2}$ for SDAOUT and SCLOUT) and the output pull down turn on has a nonzero delay, and the output has a limited maximum slew rate and even if the input slew rate is slow enough that the output catches up it will still lag the falling voltage of the input by the offset voltage, The maximum t_{PHL} occurs when the input is driven LOW with zero delay and the output is still limited by its turn on delay and the falling edge slew rate, The output falling edge slew rate (which is a function of temperature, V_{CC} or V_{CC2} , and process) as well as load current and load capacitance.

Rise Time Accelerators

During positive bus transitions a 2 mA current source is switched on to quickly slew the SDA and SCL lines HIGH once the input level of 0.6 V is exceeded. The rising edge rate should be at least 1.25 V/ μ s to guarantee turn on of the accelerators.

ACC Boost Current Enable

Users having lightly loaded systems may wish to disable the rise-time accelerators. Driving this pin to ground turns off the rise-time accelerators on all four SDA and SCL pins. Driving this pin to the V_{CC2} voltage enables normal operation of the rise-time accelerators.

Level shifting hot swappable I²C-bus and SMBus buffer

PCA9512

Resistor Pull-up Value Selection

The system pull-up resistors must be strong enough to provide a positive slew rate of 1.25 V/μs on the SDA and SCL pins, in order to activate the boost pull-up currents during rising edges. Choose maximum resistor value using the formula:

$$R \leq (V_{CC(MIN)} - 0.6) (800,000)/C$$

where R is the pull-up resistor value in ohms, V_{CC(MIN)} is the minimum V_{CC} voltage and C is the equivalent bus capacitance in picofarads (pF).

In addition, regardless of the bus capacitance, always choose R ≤ 16 kΩ for V_{CC} = 5.5 V maximum, R ≤ 24 kΩ for V_{CC} = 3.6 V maximum. The start-up circuitry requires logic HIGH voltages on SDAOUT and SCLOUT to connect the backplane to the card, and these pull-up values are needed to overcome the precharge voltage. See the curves in Figures 5 and 6 for guidance in resistor pull-up selection.

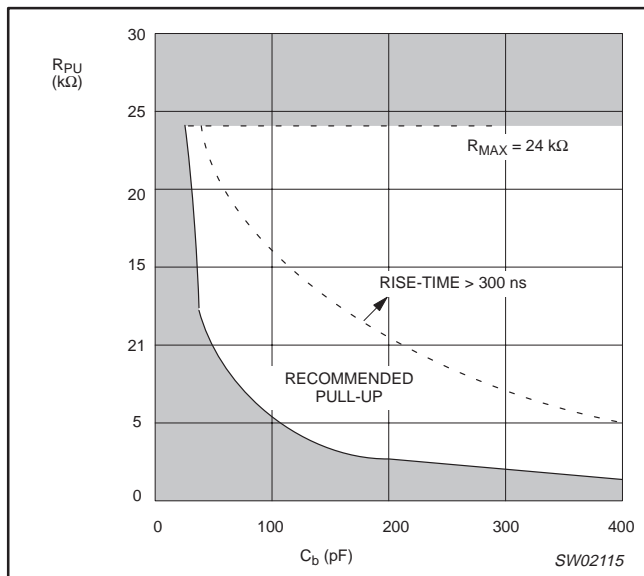

Figure 5. Bus requirements for 3.3 V systems

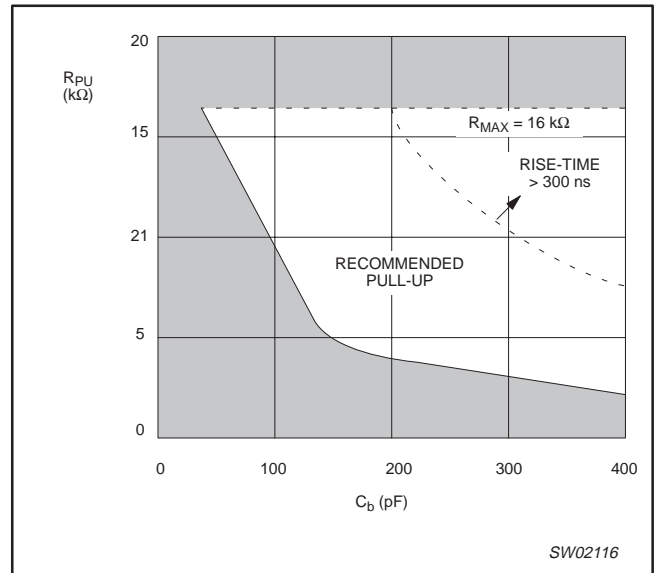

Figure 6. Bus requirements for 5 V systems

Minimum SDA and SCL Capacitance Requirements

The device connection circuitry requires a minimum capacitance loading on the SDA and SCL pins in order to function properly. The value of this capacitance is a function of V_{CC} and the bus pull-up resistance. Estimate the bus capacitance on both the backplane and the card data and clock buses, and refer to Figures 5 and 6 to choose appropriate pull-up resistor values. Note from the figures that 5 V systems should have at least 47 pF capacitance on their buses and 3.3 V systems should have at least 22 pF capacitance for proper operation of the PCA9512. Although the device has been designed to be marginally stable with smaller capacitance loads, for applications with less capacitance, provisions need to be made to add a capacitor to ground to ensure these minimum capacitance conditions if oscillations are noticed during initial signal integrity verification.

Level shifting hot swappable I²C-bus and SMBus buffer

PCA9512

Hot Swapping and Capacitance Buffering Application

Figures 7 through 9 illustrate the usage of the PCA9512 in applications that take advantage of both its hot swapping and capacitance buffering features. In all of these applications, note that if the I/O cards were plugged directly into the backplane, all of the backplane and card capacitances would add directly together, making rise- and fall-time requirements difficult to meet. Placing a

PCA9512 on the edge of each card, however, isolates the card capacitance from the backplane. For a given I/O card, the PCA9512 drives the capacitance of everything on the card and the backplane must drive only the capacitance of the bus buffer, which is less than 10 pF, the connector, trace, and all additional cards on the backplane.

See Application Note *AN10160, Hot Swap Bus Buffer* for more information on applications and technical assistance.

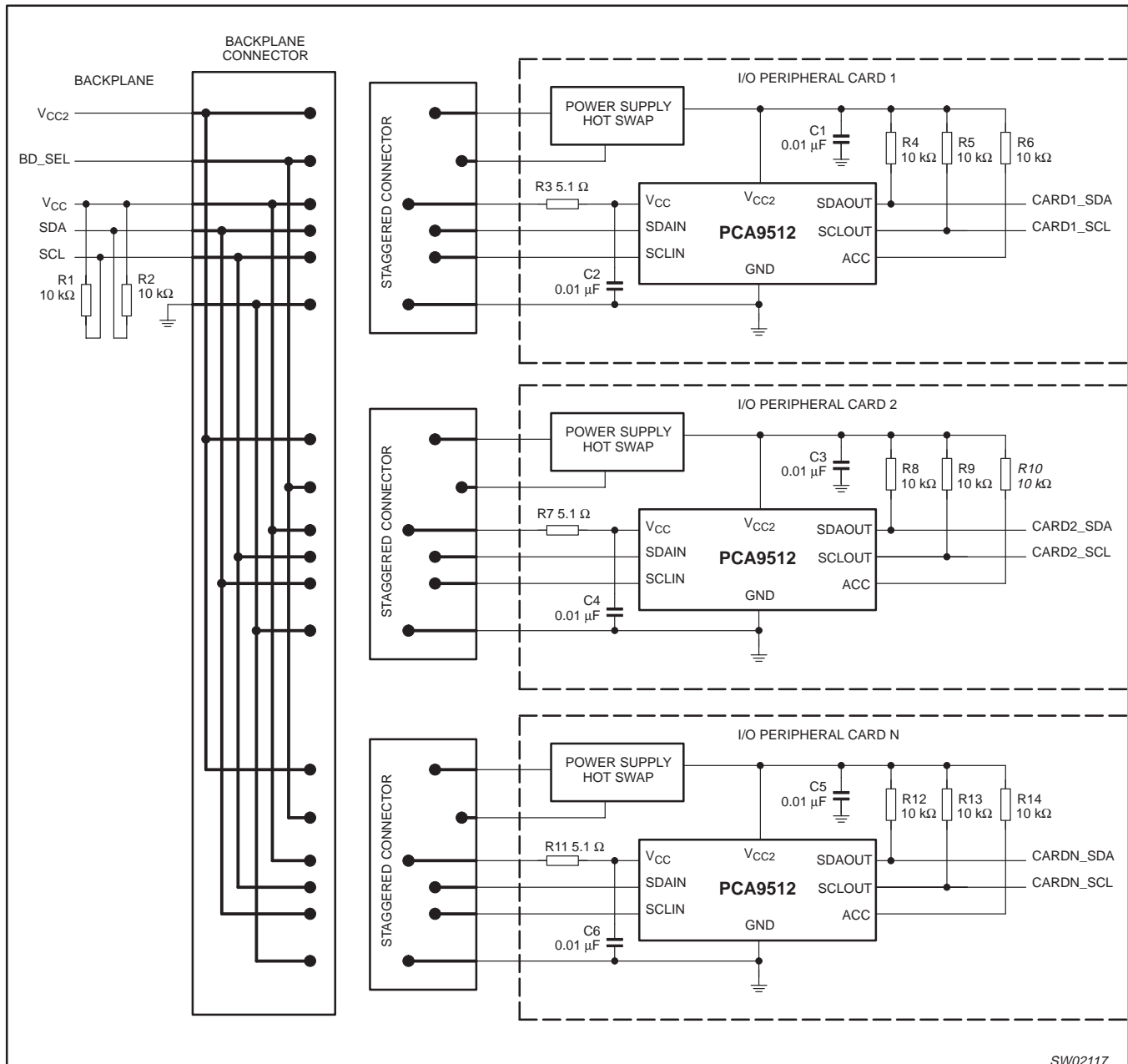

NOTE: Application assumes bus capacitance within "proper operation" region of Figures 5 and 6.

Figure 7. Hot swapping multiple I/O cards into a backplane using the PCA9512 in a CompactPCI, VME, and AdvancedTCA system

Level shifting hot swappable I²C-bus and SMBus buffer

PCA9512

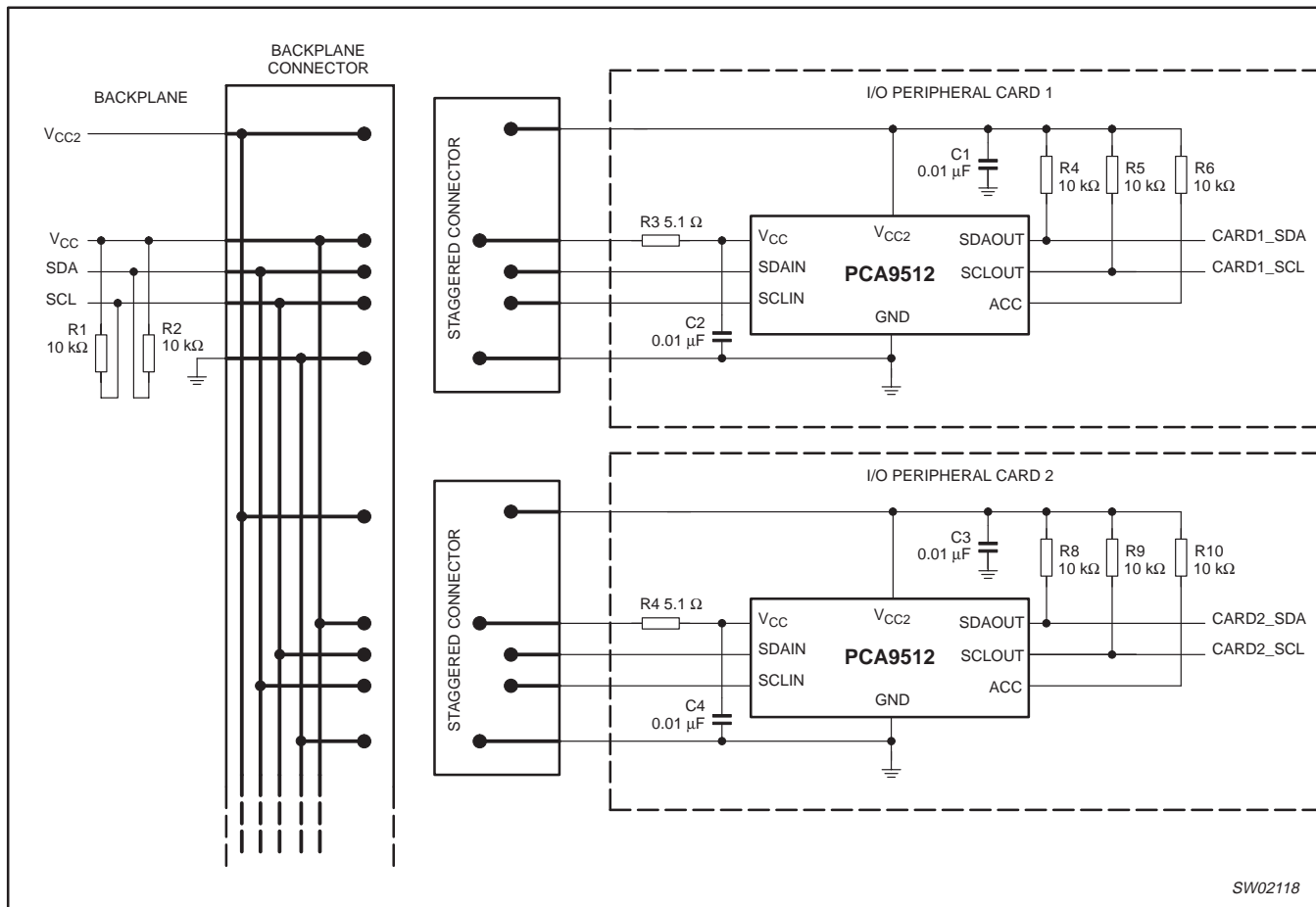

SW02118

NOTE: Application assumes bus capacitance within “proper operation” region of Figures 5 and 6.

Figure 8. Hot swapping multiple I/O cards into a backplane using the PCA9512 with a custom connector

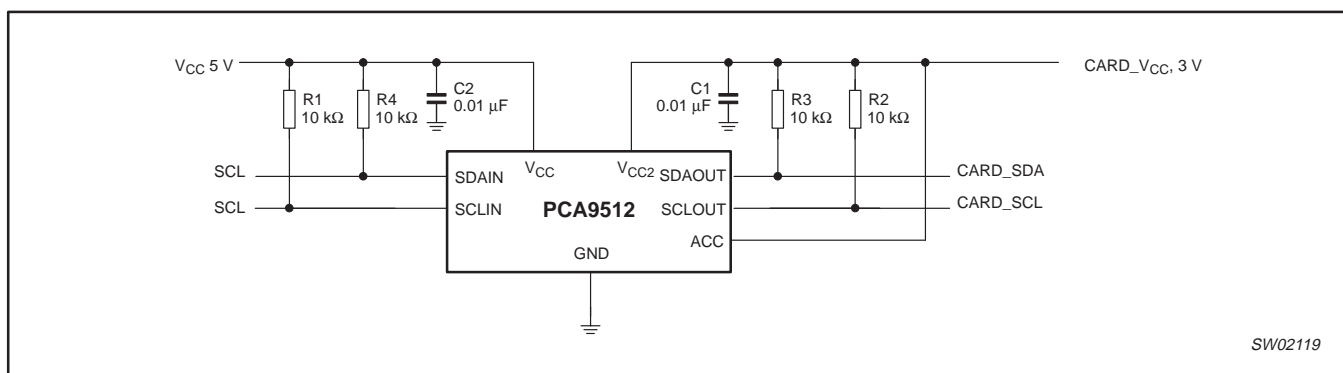

SW02119

NOTE: Application assumes bus capacitance within “proper operation” region of Figures 5 and 6.

Figure 9. 5 V to 3.3 V level translator and bus buffer

Level shifting hot swappable I²C-bus and SMBus buffer

PCA9512

ABSOLUTE MAXIMUM RATINGS

Limiting values in accordance with the Absolute Maximum System (IEC 134).
Voltages with respect to pin GND.

SYMBOL	PARAMETER	LIMITS		UNIT
		MIN.	MAX.	
V _{CC}	Supply voltage range V _{CC}	-0.5	+7	V
V _{CC2}	Supply voltage range V _{CC2}	-0.5	+7	V
V _n	SDAIN, SCLIN, SDAOUT, SCLOUT, ACC	-0.5	+7	V
I _I	Maximum current for inputs	-	± 20	mA
I _{IO}	Maximum current for I/O pins	-	± 50	mA
T _{opr}	Operating temperature range	-40	+85	°C
T _{stg}	Storage temperature range	-65	+125	°C
T _{sld}	Lead soldering temperature (10 sec max)	—	+300	°C
T _{j(max)}	Maximum junction temperature	—	+125	°C

NOTE:

- Stresses beyond those listed may cause permanent damage to the device. These are stress ratings only and functional operation of the device at these or any other conditions beyond those indicated under "recommended operating conditions" is not implied. Exposure to absolute-maximum-rated conditions for extended periods may affect device reliability.

Level shifting hot swappable I²C-bus and SMBus buffer

PCA9512

ELECTRICAL CHARACTERISTICS

$V_{CC} = 2.7\text{ V to }5.5\text{ V}$; $T_{amb} = -40\text{ }^{\circ}\text{C to }+85\text{ }^{\circ}\text{C}$ unless otherwise noted.

SYMBOL	PARAMETER	TEST CONDITIONS	LIMITS			UNIT
			MIN.	TYP.	MAX.	
Power supply						
V_{CC}	Supply voltage	Note 1.	2.7	—	5.5	V
V_{CC2}	Card side supply voltage	Note 1.	2.7	—	5.5	V
I_{VCC1}	V_{CC} supply current	$V_{CC} = 5.5\text{ V}$; $V_{SDAIN} = V_{SCLIN} = 0\text{ V}$	—	1.2	3.6	mA
I_{VCC2}	V_{CC} supply current	$V_{CC} = 5.5\text{ V}$; $V_{SDAOUT} = V_{SCLOUT} = 0\text{ V}$	—	1.1	2.4	mA
Start-up circuitry						
V_{PRE}	Precharge voltage	SDA, SCL floating; Note 1.	0.8	1.1	1.2	V
t_{EN}	Enable time on power-up	Note 6.	—	180	—	μs
t_{IDLE}	Bus idle time	Notes 1 and 7.	50	140	250	μs
Rise time accelerators						
$I_{PULLUPAC}$	Transient boosted pull-up current	Positive transition on SDA, SCL, $ACC = 0.7\text{ V} \times V_{CC2}$; $V_{CC} = 2.7\text{ V}$; Slew rate = $1.25\text{ V}/\mu\text{s}$; Note 2, Note 8	1	2	—	mA
V_{ACCDIS}	Accelerator disable threshold		$0.3 \times V_{CC2}$	$0.5 \times V_{CC2}$	—	V
V_{ACCEN}	Accelerator enable threshold		—	$0.5 \times V_{CC2}$	$0.7 \times V_{CC2}$	V
I_{VACC}	A_{CC} input current		-1	± 0.1	1	μA
t_{PDOFF}	A_{CC} delay, on/off		—	5	—	ns
Input-output connection						
V_{OS}	Input-output offset voltage	$10\text{ k}\Omega$ to V_{CC} on SDA, SCL; $V_{CC} = 3.3\text{ V}$, $V_{CC2} = 3.3\text{ V}$; $V_{IN} = 0.2\text{ V}$; Note 1; Note 3.	0	70	150	mV
f_{SCL_SDA}	operating frequency	Guaranteed by design, not subject to test	0	—	400	kHz
C_{IN}	Digital input capacitance	Guaranteed by design, not subject to test	—	—	10	pF
V_{OL}	LOW-level output voltage	Input = 0 V. SDA, SCL pins; $I_{SINK} = 3\text{ mA}$; $V_{CC} = 2.7\text{ V}$; $V_{CC2} = 2.7\text{ V}$; Note 1.	0	—	0.4	V
I_{LI}	Input leakage current	SDA, SCL pins = $V_{CC} = 5.5\text{ V}$; $V_{CC2} = 5.5\text{ V}$	-1	—	5	μA
Timing characteristics						
f_{I2C}	I ² C operating frequency	Note 4	0	—	400	kHz
t_{BUF}	Bus free time between stop and start condition	Note 4	1.3	—	—	μs
$t_{HD;STA}$	Hold time after (repeated) start condition	Note 4	0.6	—	—	μs
$t_{SU;STA}$	Repeated start condition setup time	Note 4	0.6	—	—	μs
$t_{SU;STO}$	Stop condition setup time	Note 4	0.6	—	—	μs
$t_{HD;DAT}$	Data hold time	Note 4	300	—	—	ns
$t_{SU;DAT}$	Data setup time	Note 4	100	—	—	ns
t_{LOW}	Clock LOW period	Note 4	1.3	—	—	μs
t_{HIGH}	Clock HIGH period	Note 4	0.6	—	—	μs
t_f	Clock, data fall time	Notes 4 and 5	$20 + 0.1 \times C_B$	—	300	ns
t_r	Clock, data rise time	Notes 4 and 5	$20 + 0.1 \times C_B$	—	300	ns

NOTES:

1. This specification applies over the full operating temperature range.
2. $I_{PULLUPAC}$ varies with temperature and V_{CC} voltage, as shown in the Typical Performance Characteristics section.

Level shifting hot swappable I²C-bus and SMBus buffer

PCA9512

3. The connection circuitry always regulates its output to a higher voltage than its input. The magnitude of this offset voltage as a function of the pull-up resistor and V_{CC} voltage is shown in the Typical Performance Characteristics section.
4. Guaranteed by design, not production tested.
5. C_B = total capacitance of one bus line in pF.
6. Enable time is from power-up of V_{CC} and V_{CC2} ≥ 2.7 V to when idle or stop time begins.
7. Idle time is from when SDAx and SCLx are HIGH after enable time has been met.
8. Input pull-up voltage should not exceed power supply voltage in operating mode because the rise time accelerator will clamp the voltage to the positive supply rail.

TYPICAL PERFORMANCE CHARACTERISTICS

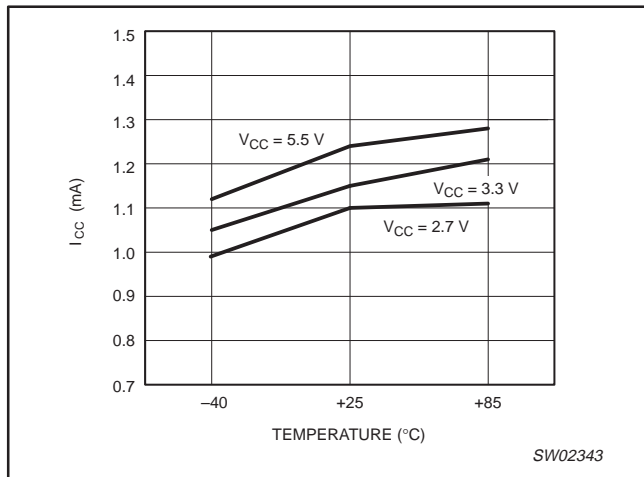

Figure 10. I_{CC} versus Temperature (Note 1)

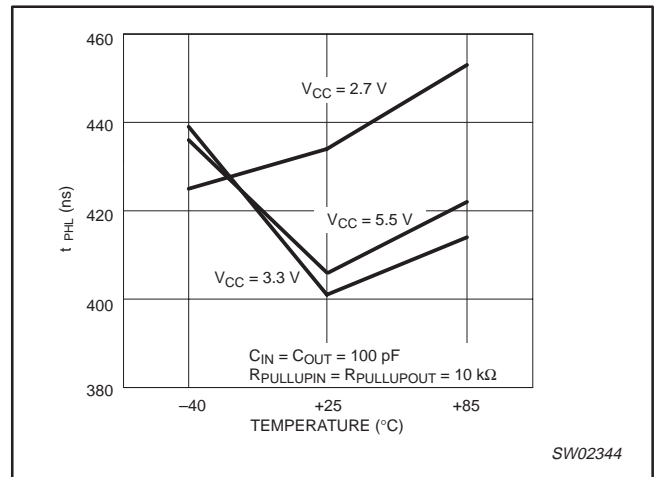

Figure 12. Input-output t_{PHL} versus Temperature

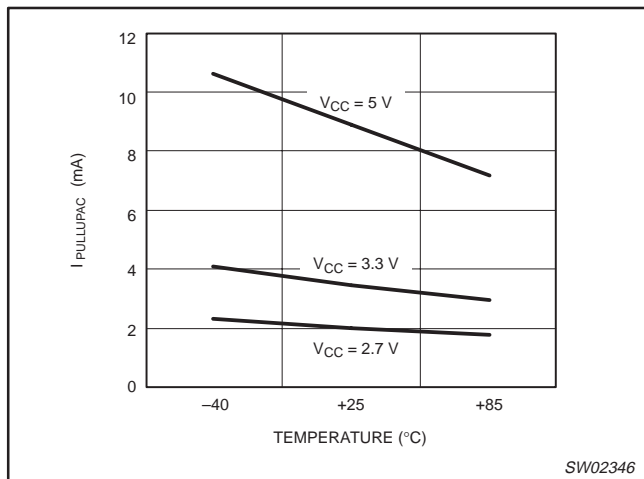

Figure 11. I_{PULLUPAC} versus Temperature

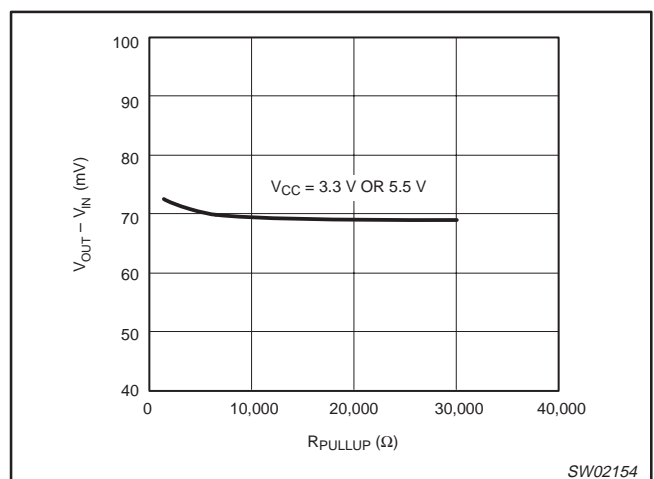

Figure 13. Connection circuitry V_{OUT} - V_{IN}

NOTE:

1. I_{CC2} (Pin 1) typical current averages 0.1 mA less than I_{CC} on Pin 8.

Level shifting hot swappable I²C-bus and SMBus buffer

PCA9512

TEST CIRCUIT

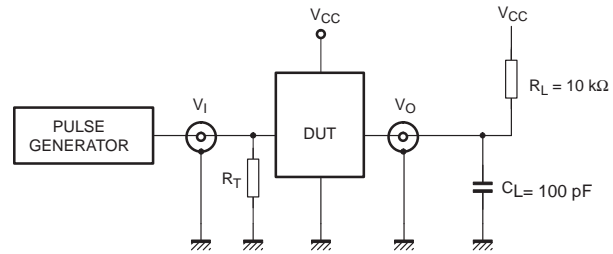

DEFINITIONS

R_L = Load resistor.

C_L = Load capacitance includes jig and probe capacitance

R_T = Termination resistance should be equal to the output impedance Z_O of the pulse generators.

SW02345

Figure 14. Test circuitry for switching times

Level shifting hot swappable I²C-bus and SMBus buffer

PCA9512

SO8: plastic small outline package; 8 leads; body width 3.9 mm

SOT96-1

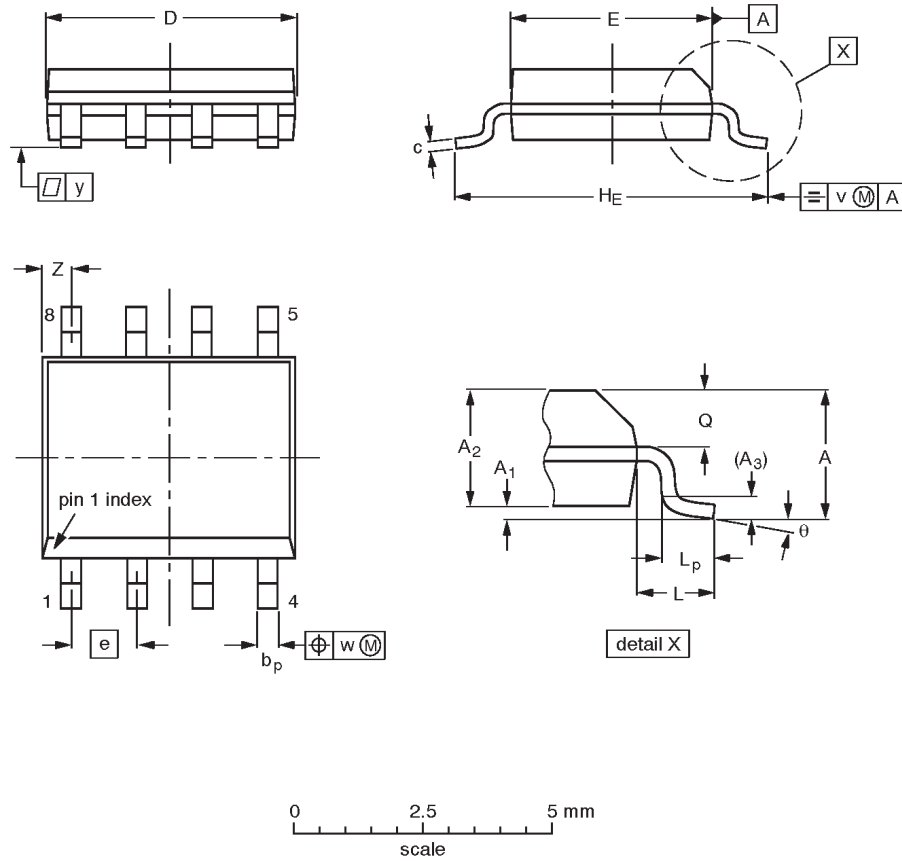

DIMENSIONS (inch dimensions are derived from the original mm dimensions)

UNIT	A max.	A ₁	A ₂	A ₃	b _p	c	D ⁽¹⁾	E ⁽²⁾	e	H _E	L	L _p	Q	v	w	y	z ⁽¹⁾	θ
mm	1.75	0.25 0.10	1.45 1.25	0.25	0.49 0.36	0.25 0.19	5.0 4.8	4.0 3.8	1.27	6.2 5.8	1.05	1.0 0.4	0.7 0.6	0.25	0.25	0.1	0.7 0.3	8° 0°
inches	0.069	0.010 0.004	0.057 0.049	0.01	0.019 0.014	0.0100 0.0075	0.20 0.19	0.16 0.15	0.05	0.244 0.228	0.041	0.039 0.016	0.028 0.024	0.01	0.01	0.004	0.028 0.012	

Notes

1. Plastic or metal protrusions of 0.15 mm (0.006 inch) maximum per side are not included.
2. Plastic or metal protrusions of 0.25 mm (0.01 inch) maximum per side are not included.

OUTLINE VERSION	REFERENCES				EUROPEAN PROJECTION	ISSUE DATE
	IEC	JEDEC	JEITA			
SOT96-1	076E03	MS-012				99-12-27 03-02-18

Level shifting hot swappable I²C-bus and SMBus buffer

PCA9512

TSSOP8: plastic thin shrink small outline package; 8 leads; body width 3 mm

SOT505-1

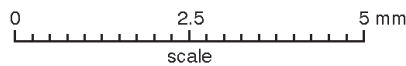
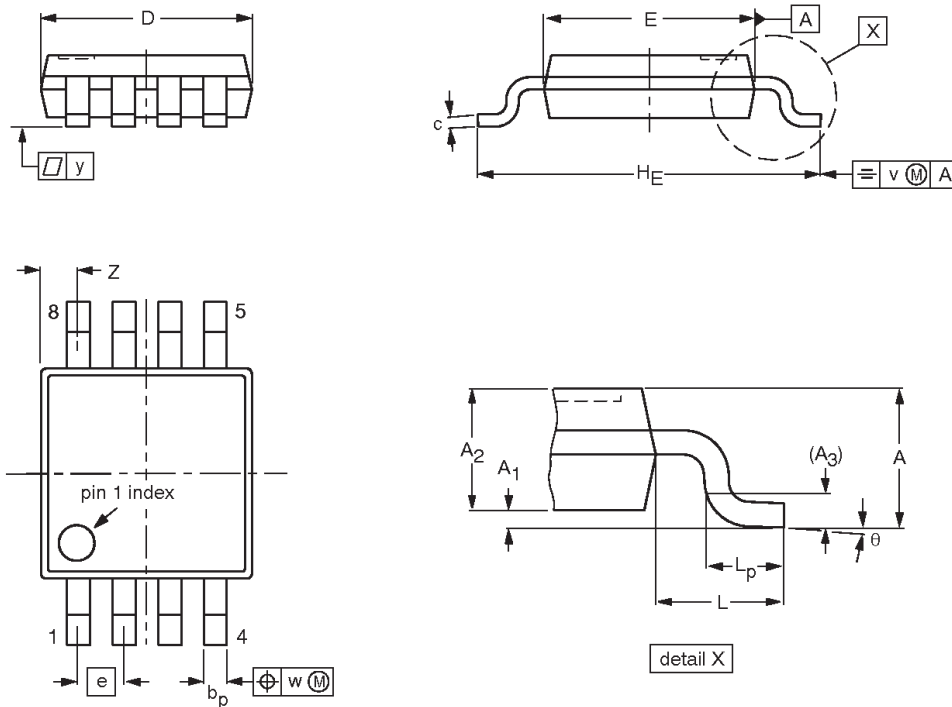

DIMENSIONS (mm are the original dimensions)

UNIT	A max.	A ₁	A ₂	A ₃	b _p	c	D ⁽¹⁾	E ⁽²⁾	e	H _E	L	L _p	v	w	y	Z ⁽¹⁾	θ
mm	1.1	0.15 0.05	0.95 0.80	0.25	0.45 0.25	0.28 0.15	3.1 2.9	3.1 2.9	0.65	5.1 4.7	0.94	0.7 0.4	0.1	0.1	0.1	0.70 0.35	6° 0°

Notes

1. Plastic or metal protrusions of 0.15 mm maximum per side are not included.
2. Plastic or metal protrusions of 0.25 mm maximum per side are not included.

OUTLINE VERSION	REFERENCES				EUROPEAN PROJECTION	ISSUE DATE
	IEC	JEDEC	JEITA			
SOT505-1						99-04-09 03-02-18

Level shifting hot swappable I²C-bus and SMBus buffer

PCA9512

REVISION HISTORY

Rev	Date	Description
PCA9512_2	20090508	Product data sheet. Modifications: <ul style="list-style-type: none">• Page 2, Features section: added (new) 4th bullet item• Page 2, Features section: deleted (old) 9th bullet item ("5.5 V tolerant I/Os")• Electrical characteristics table: added table note 8 and its reference in the "Test conditions" column of sub-section "Rise time accelerators", symbol I_{PULLUPAC}• Updated legal disclaimers.
PCA9512_1	20041005	Product data sheet (9397 750 14005).

Level shifting hot swappable I²C-bus and SMBus buffer

PCA9512

Legal Information

Data sheet status

Document status ^{[1][2]}	Product status ^[3]	Definition
Objective [short] data sheet	Development	This document contains data from the objective specification for product development.
Preliminary [short] data sheet	Qualification	This document contains data from the preliminary specification.
Product [short] data sheet	Production	This document contains the product specification.

[1] Please consult the most recently issued document before initiating or completing a design.

[2] The term 'short data sheet' is explained in section "Definitions".

[3] The product status of device(s) described in this document may have changed since this document was published and may differ in case of multiple devices. The latest product status information is available on the Internet at URL <http://www.nxp.com>.

Definitions

Draft — The document is a draft version only. The content is still under internal review and subject to formal approval, which may result in modifications or additions. NXP Semiconductors does not give any representations or warranties as to the accuracy or completeness of information included herein and shall have no liability for the consequences of use of such information.

Short data sheet — A short data sheet is an extract from a full data sheet with the same product type number(s) and title. A short data sheet is intended for quick reference only and should not be relied upon to contain detailed and full information. For detailed and full information see the relevant full data sheet, which is available on request via the local NXP Semiconductors sales office. In case of any inconsistency or conflict with the short data sheet, the full data sheet shall prevail.

Disclaimers

General — Information in this document is believed to be accurate and reliable. However, NXP Semiconductors does not give any representations or warranties, expressed or implied, as to the accuracy or completeness of such information and shall have no liability for the consequences of use of such information.

Right to make changes — NXP Semiconductors reserves the right to make changes to information published in this document, including without limitation specifications and product descriptions, at any time and without notice. This document supersedes and replaces all information supplied prior to the publication hereof.

Suitability for use — NXP Semiconductors products are not designed, authorized or warranted to be suitable for use in medical, military, aircraft, space or life support equipment, nor in applications where failure or malfunction of an NXP Semiconductors product can reasonably be expected to result in personal injury, death or severe property or environmental damage. NXP Semiconductors accepts no liability for inclusion and/or use of

NXP Semiconductors products in such equipment or applications and therefore such inclusion and/or use is at the customer's own risk.

Applications — Applications that are described herein for any of these products are for illustrative purposes only. NXP Semiconductors makes no representation or warranty that such applications will be suitable for the specified use without further testing or modification.

Limiting values — Stress above one or more limiting values (as defined in the Absolute Maximum Ratings System of IEC 60134) may cause permanent damage to the device. Limiting values are stress ratings only and operation of the device at these or any other conditions above those given in the Characteristics sections of this document is not implied. Exposure to limiting values for extended periods may affect device reliability.

Terms and conditions of sale — NXP Semiconductors products are sold subject to the general terms and conditions of commercial sale, as published at <http://www.nxp.com/profile/terms>, including those pertaining to warranty, intellectual property rights infringement and limitation of liability, unless explicitly otherwise agreed to in writing by NXP Semiconductors. In case of any inconsistency or conflict between information in this document and such terms and conditions, the latter will prevail.

No offer to sell or license — Nothing in this document may be interpreted or construed as an offer to sell products that is open for acceptance or the grant, conveyance or implication of any license under any copyrights, patents or other industrial or intellectual property rights.

Export control — This document as well as the item(s) described herein may be subject to export control regulations. Export might require a prior authorization from national authorities.

Trademarks

Notice: All referenced brands, product names, service names and trademarks are the property of their respective owners.

I²C-bus — logo is a trademark of NXP B.V.

Contact information

For additional information please visit: <http://www.nxp.com>

For sales office addresses, send an e-mail to: salesaddresses@nxp.com

Please be aware that important notices concerning this document and the product(s) described herein, have been included in section "Legal information".

founded by

PHILIPS

© NXP B.V. 2009. All rights reserved.

For more information, please visit <http://www.nxp.com>.

For sales office addresses, please send an email to: salesaddresses@nxp.com.

Date of release: 20090508

Document identifier: PCA9512_2