

74HC3GU04

Inverter

Rev. 03 — 11 May 2009

Product data sheet

1. General description

The 74HC3GU04 is a high-speed Si-gate CMOS device. This device provides three inverter gates with unbuffered outputs.

The 74HC3GU04 has CMOS input switching levels and supply voltage range 2 V to 6 V.

2. Features

- Wide supply voltage range from 2.0 V to 6.0 V
- Symmetrical output impedance
- High noise immunity
- Low-power dissipation
- Balanced propagation delays
- Multiple package options
- ESD protection:
 - ◆ HBM JESD22-A114E exceeds 2000 V
 - ◆ MM JESD22-A115-A exceeds 200 V
- Specified from $-40\text{ }^{\circ}\text{C}$ to $+85\text{ }^{\circ}\text{C}$ and $-40\text{ }^{\circ}\text{C}$ to $+125\text{ }^{\circ}\text{C}$

3. Ordering information

Table 1. Ordering information

Type number	Package			
	Temperature range	Name	Description	Version
74HC3GU04DP	$-40\text{ }^{\circ}\text{C}$ to $+125\text{ }^{\circ}\text{C}$	TSSOP8	plastic thin shrink small outline package; 8 leads; body width 3 mm; lead length 0.5 mm	SOT505-2
74HC3GU04DC	$-40\text{ }^{\circ}\text{C}$ to $+125\text{ }^{\circ}\text{C}$	VSSOP8	plastic very thin shrink small outline package; 8 leads; body width 2.3 mm	SOT765-1
74HC3GU04GD	$-40\text{ }^{\circ}\text{C}$ to $+125\text{ }^{\circ}\text{C}$	XSON8U	plastic extremely thin small outline package; no leads; 8 terminals; UTLP based; body $3 \times 2 \times 0.5$ mm	SOT996-2

4. Marking

Table 2. Marking

Type number	Marking code
74HC3GU04DP	HU04
74HC3GU04DC	HU4
74HC3GU04GD	HU4

5. Functional diagram

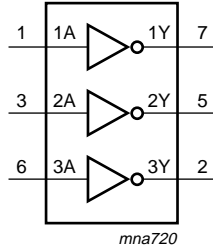

Fig 1. Logic symbol

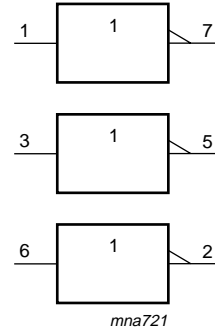

Fig 2. IEC logic symbol

6. Pinning information

6.1 Pinning

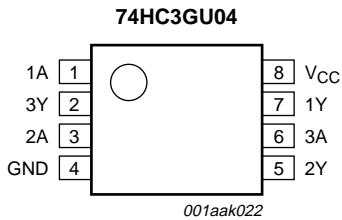

Fig 3. Pin configuration SOT505-2 (TSSOP8) and SOT765-1 (VSSOP8)

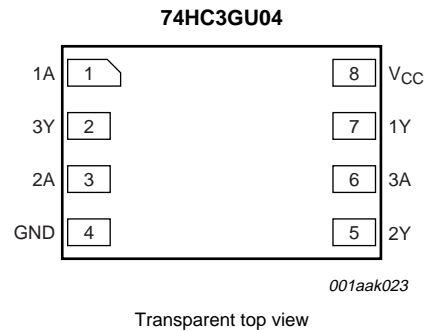

Fig 4. Pin configuration SOT996-2 (XSON8U)

6.2 Pin description

Table 3. Pin description

Symbol	Pin	Description
1A, 2A, 3A	1, 3, 6	data input
1Y, 2Y, 3Y	7, 5, 2	data output
GND	4	ground (0 V)
V _{CC}	8	supply voltage

7. Functional description

Table 4. Function table [1]

Input	Output
nA	nY
L	H
H	L

[1] H = HIGH voltage level; L = LOW voltage level.

8. Limiting values

Table 5. Limiting values

In accordance with the Absolute Maximum Rating System (IEC 60134). Voltages are referenced to GND (ground = 0 V).

Symbol	Parameter	Conditions	Min	Max	Unit
V_{CC}	supply voltage		-0.5	+7.0	V
I_{IK}	input clamping current	$V_I < -0.5\text{ V}$ or $V_I > V_{CC} + 0.5\text{ V}$	[1] -	± 20	mA
I_{OK}	output clamping current	$V_O < -0.5\text{ V}$ or $V_O > V_{CC} + 0.5\text{ V}$	[1] -	± 20	mA
I_O	output current	$V_O = -0.5\text{ V}$ to $(V_{CC} + 0.5\text{ V})$	[1] -	± 25	mA
I_{CC}	quiescent supply current		[1] -	50	mA
I_{GND}	ground current		[1] -50	-	mA
T_{stg}	storage temperature		-65	+150	°C
P_{tot}	total power dissipation	$T_{amb} = -40\text{ °C}$ to $+125\text{ °C}$	[2] -	300	mW

[1] The input and output voltage ratings may be exceeded if the input and output current ratings are observed.

[2] For TSSOP8 package: above 55 °C the value of P_{tot} derates linearly with 2.5 mW/K.
 For VSSOP8 package: above 110 °C the value of P_{tot} derates linearly with 8 mW/K.
 For XSON8U package: above 118 °C the value of P_{tot} derates linearly with 7.8 mW/K.

9. Recommended operating conditions

Table 6. Recommended operating conditions

Voltages are referenced to GND (ground = 0 V).

Symbol	Parameter	Conditions	Min	Typ	Max	Unit
V_{CC}	supply voltage		2.0	5.0	6.0	V
V_I	input voltage		0	-	V_{CC}	V
V_O	output voltage		0	-	V_{CC}	V
T_{amb}	ambient temperature		-40	+25	+125	°C
$\Delta t/\Delta V$	input transition rise and fall rate	$V_{CC} = 2.0\text{ V}$	-	-	625	ns/V
		$V_{CC} = 4.5\text{ V}$	-	1.67	139	ns/V
		$V_{CC} = 6.0\text{ V}$	-	-	83	ns/V

10. Static characteristics

Table 7. Static characteristics

Voltages are referenced to GND (ground = 0 V).

Symbol	Parameter	Conditions	-40 °C to +85 °C			-40 °C to +125 °C		Unit
			Min	Typ ^[1]	Max	Min	Max	
V _{IH}	HIGH-level input voltage	V _{CC} = 2.0 V	1.7	1.1	-	1.7	-	V
		V _{CC} = 4.5 V	3.6	2.4	-	3.6	-	V
		V _{CC} = 6.0 V	4.8	3.1	-	4.8	-	V
V _{IL}	LOW-level input voltage	V _{CC} = 2.0 V	-	0.9	0.3	-	0.3	V
		V _{CC} = 4.5 V	-	2.1	0.9	-	0.9	V
		V _{CC} = 6.0 V	-	2.9	1.2	-	1.2	V
V _{OH}	HIGH-level output voltage	V _I = V _{IH} or V _{IL}						
		I _O = -20 μA; V _{CC} = 2.0 V	1.9	2.0	-	1.9	-	V
		I _O = -20 μA; V _{CC} = 4.5 V	4.4	4.5	-	4.4	-	V
		I _O = -20 μA; V _{CC} = 6.0 V	5.9	6.0	-	5.9	-	V
		I _O = -4.0 mA; V _{CC} = 4.5 V	4.13	4.32	-	3.7	-	V
V _{OL}	LOW-level output voltage	V _I = V _{IH} or V _{IL}						
		I _O = 20 μA; V _{CC} = 2.0 V	-	0	0.1	-	0.1	V
		I _O = 20 μA; V _{CC} = 4.5 V	-	0	0.1	-	0.1	V
		I _O = 20 μA; V _{CC} = 6.0 V	-	0	0.1	-	0.1	V
		I _O = 4.0 mA; V _{CC} = 4.5 V	-	0.15	0.33	-	0.4	V
I _I	input leakage current	V _I = V _{CC} or GND; V _{CC} = 6.0 V	-	-	±1.0	-	±1.0	μA
		I _O = 0 A; V _{CC} = 6.0 V	-	-	10	-	20	μA
I _{CC}	supply current	per input pin; V _I = V _{CC} or GND; I _O = 0 A; V _{CC} = 6.0 V	-	-	10	-	20	μA
C _I	input capacitance		-	3.0	-	-	-	pF

[1] All typical values are measured at T_{amb} = 25 °C.

11. Dynamic characteristics

Table 8. Dynamic characteristics

Voltages are referenced to GND (ground = 0 V); for test circuit see [Figure 6](#).

Symbol	Parameter	Conditions	-40 °C to +85 °C			-40 °C to +125 °C		Unit
			Min	Typ ^[1]	Max	Min	Max	
t _{pd}	propagation delay	nA to nY; see Figure 5 ^[2]						
		V _{CC} = 2.0 V	-	13	75	-	90	ns
		V _{CC} = 4.5 V	-	6	15	-	18	ns
		V _{CC} = 6.0 V	-	5	13	-	15	ns

Table 8. Dynamic characteristics ...continued
 Voltages are referenced to GND (ground = 0 V); for test circuit see [Figure 6](#).

Symbol	Parameter	Conditions	-40 °C to +85 °C			-40 °C to +125 °C		Unit
			Min	Typ ^[1]	Max	Min	Max	
t _t	transition time	nY; see Figure 5						
		V _{CC} = 2.0 V	-	18	95	-	125	ns
		V _{CC} = 4.5 V	-	6	19	-	25	ns
		V _{CC} = 6.0 V	-	5	16	-	20	ns
C _{PD}	power dissipation capacitance	V _I = GND to V _{CC}	-	5	-	-	-	pF

- [1] All typical values are measured at T_{amb} = 25 °C.
- [2] t_{pd} is the same as t_{PLH} and t_{PHL}.
- [3] t_t is the same as t_{TLH} and t_{THL}.
- [4] C_{PD} is used to determine the dynamic power dissipation (P_D in μW).
 $P_D = C_{PD} \times V_{CC}^2 \times f_i \times N + \Sigma(C_L \times V_{CC}^2 \times f_o)$ where:
 f_i = input frequency in MHz;
 f_o = output frequency in MHz;
 C_L = output load capacitance in pF;
 V_{CC} = supply voltage in V;
 N = number of inputs switching;
 Σ(C_L × V_{CC}² × f_o) = sum of outputs.

12. Waveforms

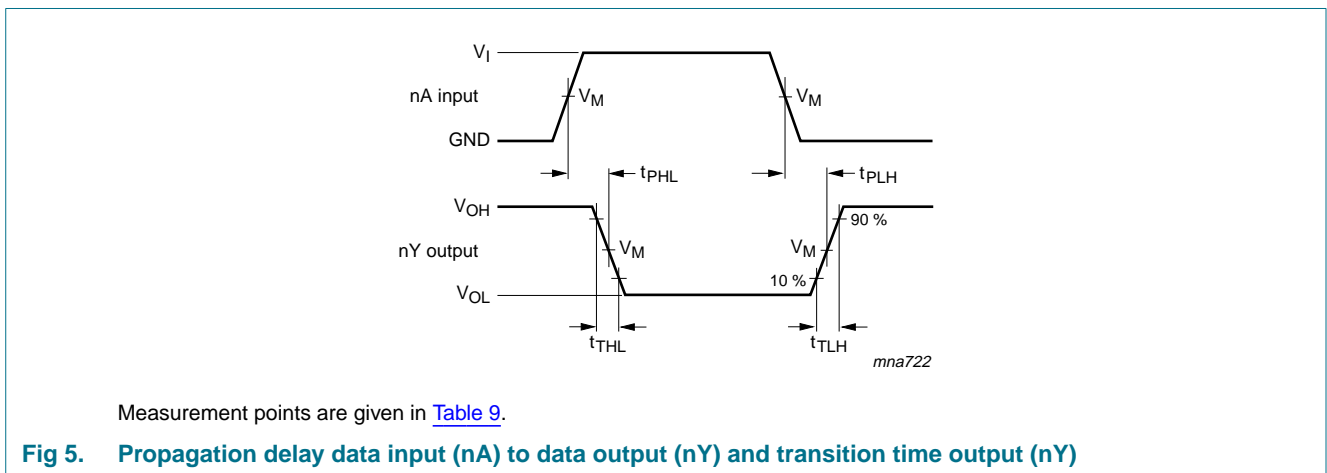
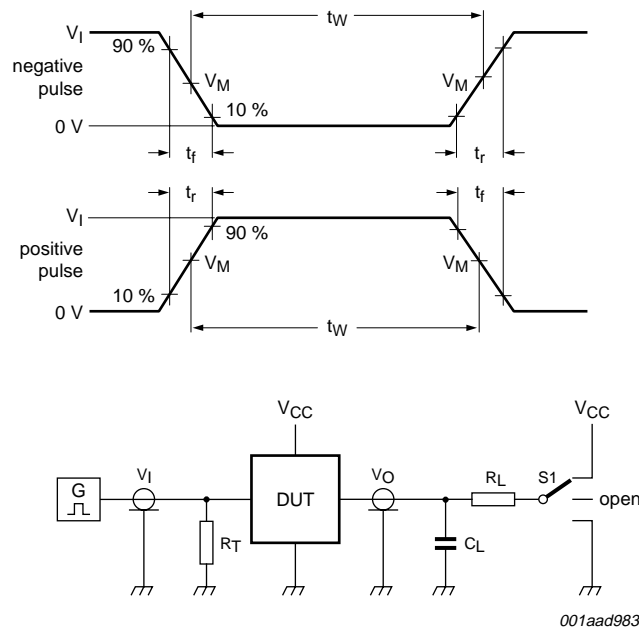

Table 9. Measurement points

Type	Input	Output
	V _M	V _M
74HC3GU04	0.5 × V _{CC}	0.5 × V _{CC}



Test data is given in [Table 10](#).

Definitions for test circuit:

R_T = Termination resistance should be equal to output impedance Z_o of the pulse generator.

C_L = Load capacitance including jig and probe capacitance.

R_L = Load resistance.

$S1$ = Test selection switch.

Fig 6. Test circuit for measuring switching times

Table 10. Test data

Type	Input		Load		S1 position
	V_I	t_r, t_f	C_L	R_L	t_{PHL}, t_{PLH}
74HC3GU04	GND to V_{CC}	≤ 6 ns	50 pF	1 k Ω	open

12.1 Additional characteristics

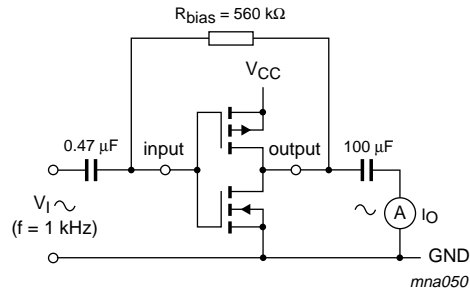

$$g_{fs} = \frac{\Delta I_o}{\Delta V_i}$$

V_O is constant.

Fig 7. Test set-up for measuring forward transconductance

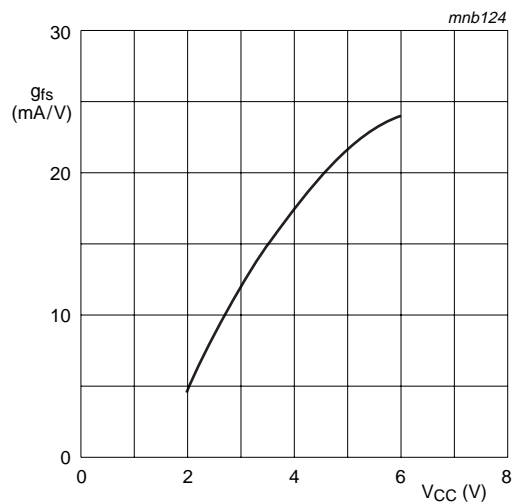

T_{amb} = 25 °C.

Fig 8. Typical forward transconductance as a function of supply voltage

13. Typical transfer characteristics

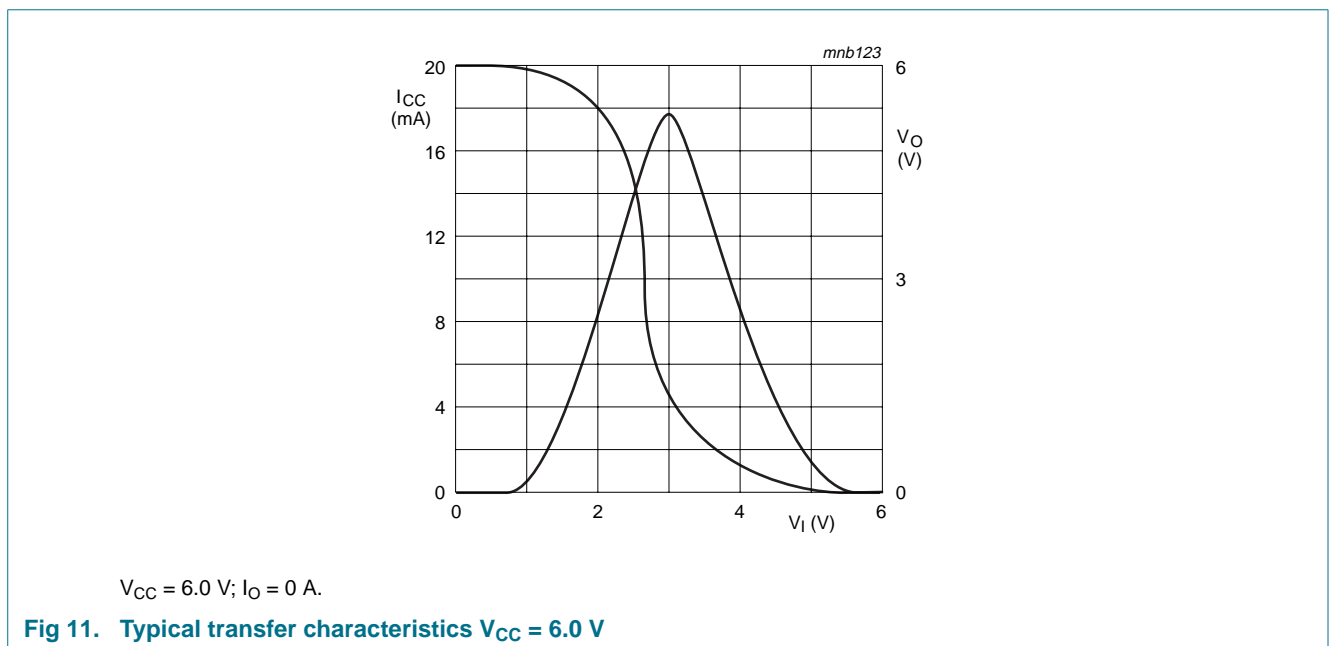
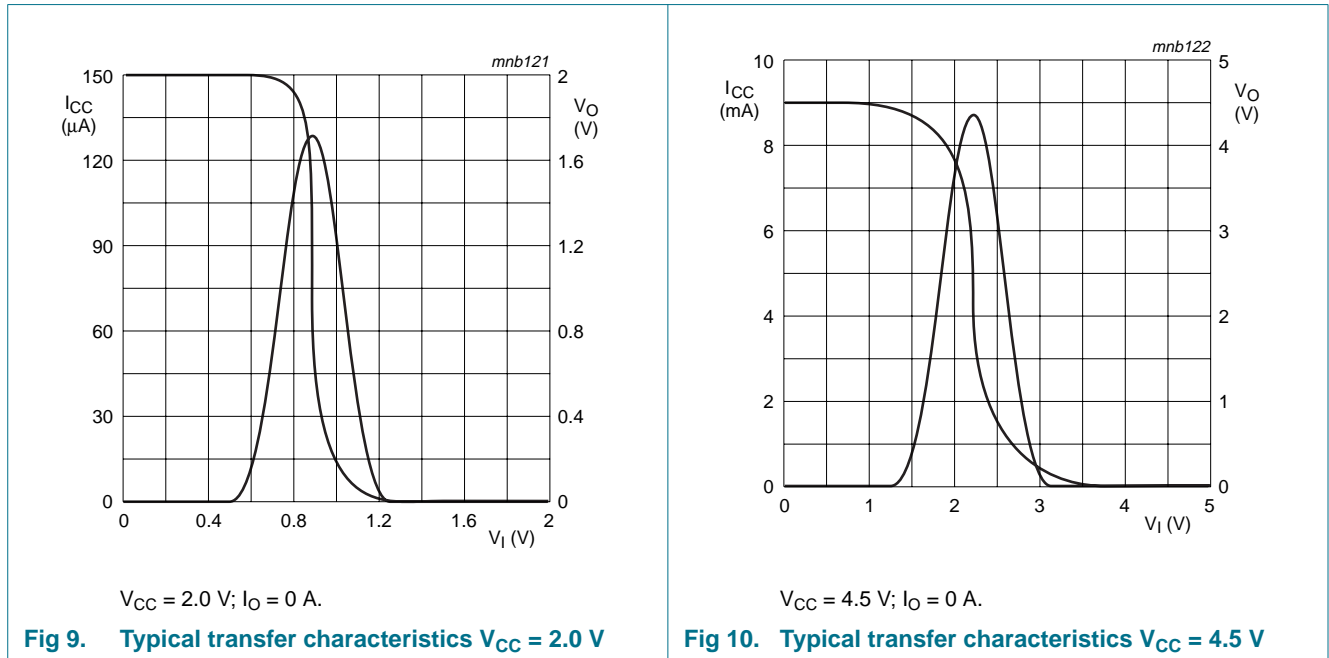

14. Application information

Some applications for the 74HC3GU04 are:

- Linear amplifier (see [Figure 12](#))
- Crystal oscillator (see [Figure 14](#)).

Remark: All values given are typical values unless otherwise specified.

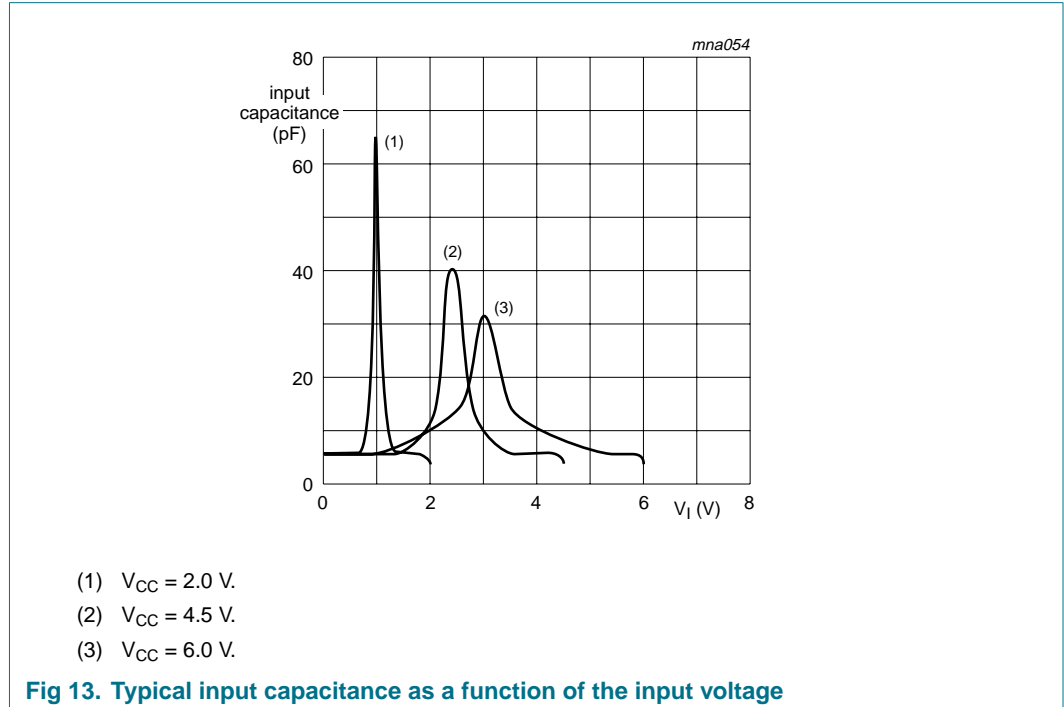
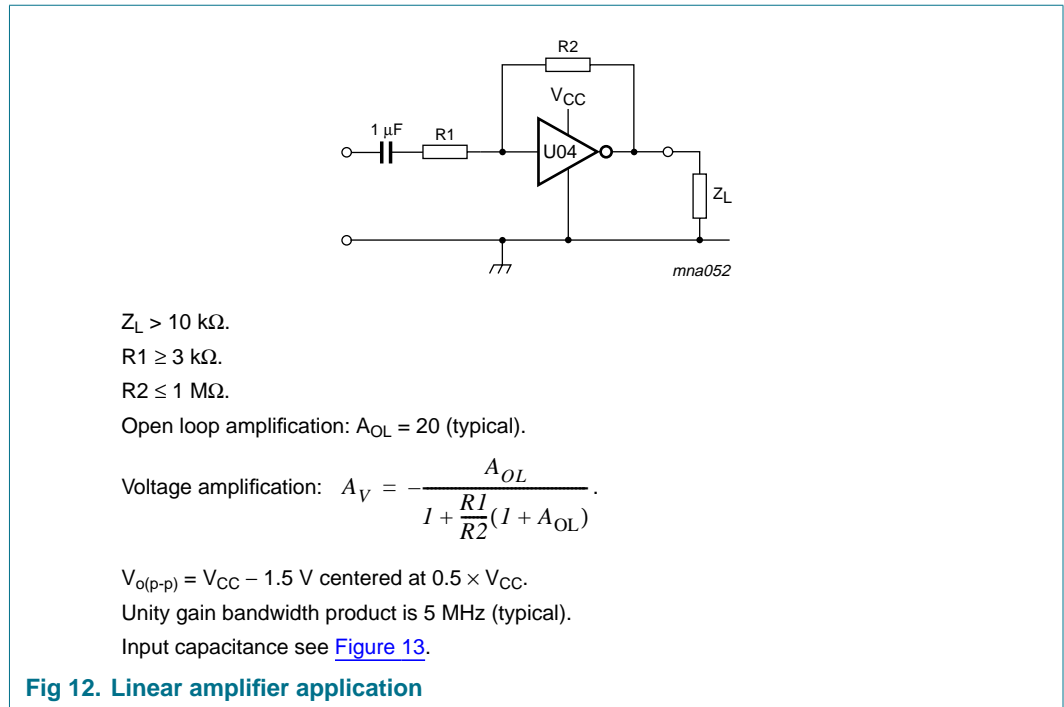

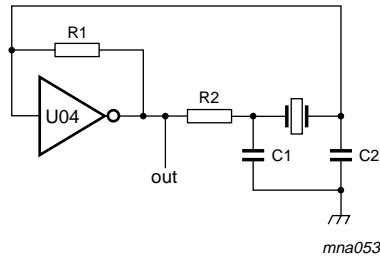

Test data is given in [Table 11](#) and [Table 12](#).

C1 = 47 pF (typical).

C2 = 22 pF (typical).

R1 = 1 MΩ to 10 MΩ (typical).

R2 optimum value depends on the frequency and required stability against changes in V_{CC} or average minimum I_{CC} ($I_{CC} = 2 \text{ mA}$ at $V_{CC} = 3.0 \text{ V}$ and $f = 1 \text{ MHz}$)

Fig 14. Crystal oscillator application

Table 11. External components for resonator (f < 1 MHz)

Frequency	R1	R2	C1	C2
10 kHz to 15.9 kHz	2.2 MΩ	220 kΩ	56 pF	20 pF
16 kHz to 24.9 kHz	2.2 MΩ	220 kΩ	56 pF	10 pF
25 kHz to 54.9 kHz	2.2 MΩ	100 kΩ	56 pF	10 pF
55 kHz to 129.9 kHz	2.2 MΩ	100 kΩ	47 pF	5 pF
130 kHz to 199.9 kHz	2.2 MΩ	47 kΩ	47 pF	5 pF
200 kHz to 349.9 kHz	2.2 MΩ	47 kΩ	47 pF	5 pF
350 kHz to 600 kHz	2.2 MΩ	47 kΩ	47 pF	5 pF

Table 12. Optimum value for R2

Frequency	R2	Optimum
3 kHz	2.0 kΩ	minimum required I_{CC}
	8.0 kΩ	minimum influence due to change in V_{CC}
6 kHz	1.0 kΩ	minimum required I_{CC}
	4.7 kΩ	minimum influence by V_{CC}
10 kHz	0.5 kΩ	minimum required I_{CC}
	2.0 kΩ	minimum influence by V_{CC}
14 kHz	0.5 kΩ	minimum required I_{CC}
	2.0 kΩ	minimum influence by V_{CC}
> 14 kHz	replace R2 by C3 = 35 pF (typical)	

15. Package outline

TSSOP8: plastic thin shrink small outline package; 8 leads; body width 3 mm; lead length 0.5 mm SOT505-2

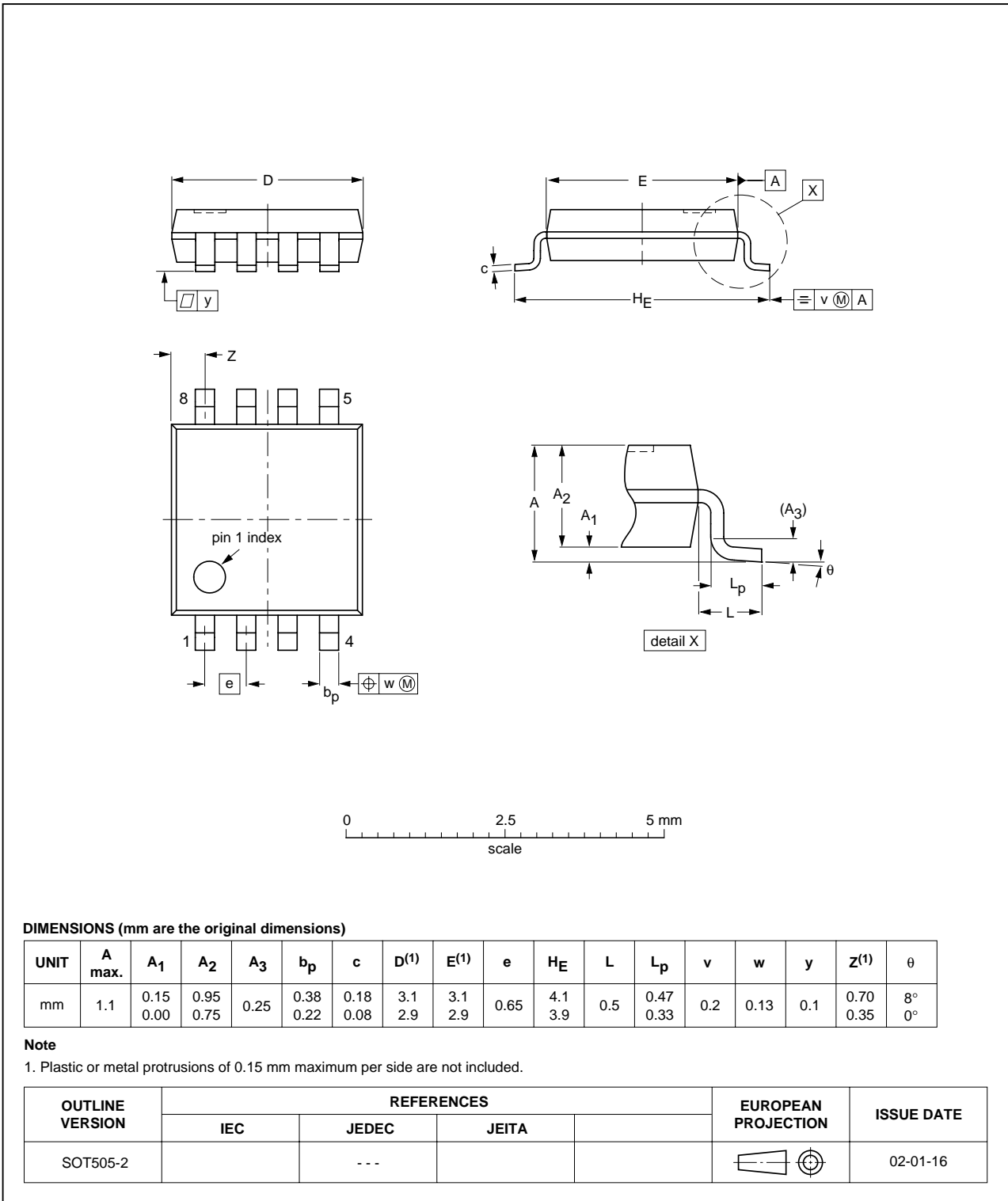

Fig 15. Package outline SOT505-2 (TSSOP8)

VSSOP8: plastic very thin shrink small outline package; 8 leads; body width 2.3 mm

SOT765-1

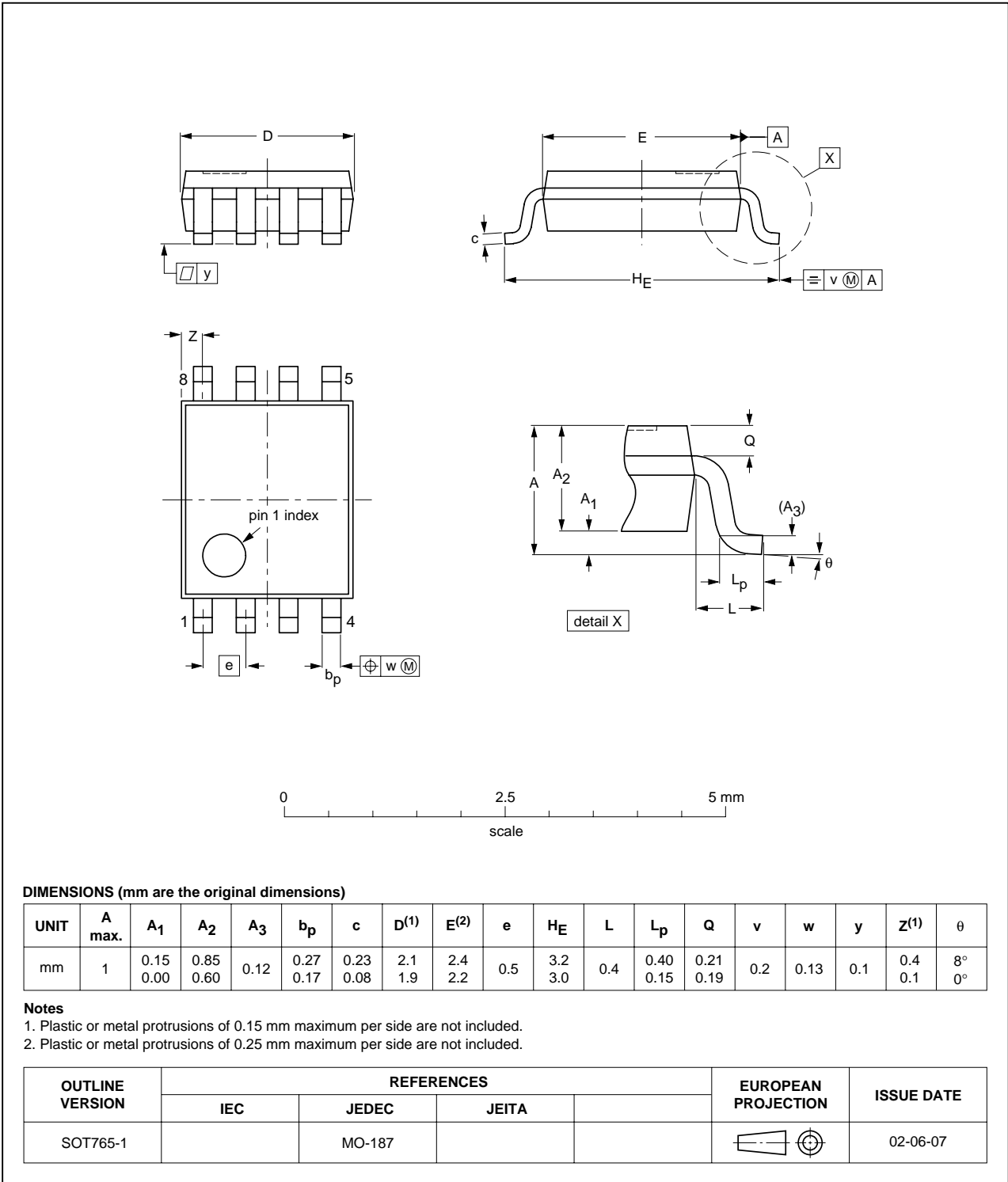

Fig 16. Package outline SOT765-1 (VSSOP8)

XSON8U: plastic extremely thin small outline package; no leads;
8 terminals; UTLP based; body 3 x 2 x 0.5 mm

SOT996-2

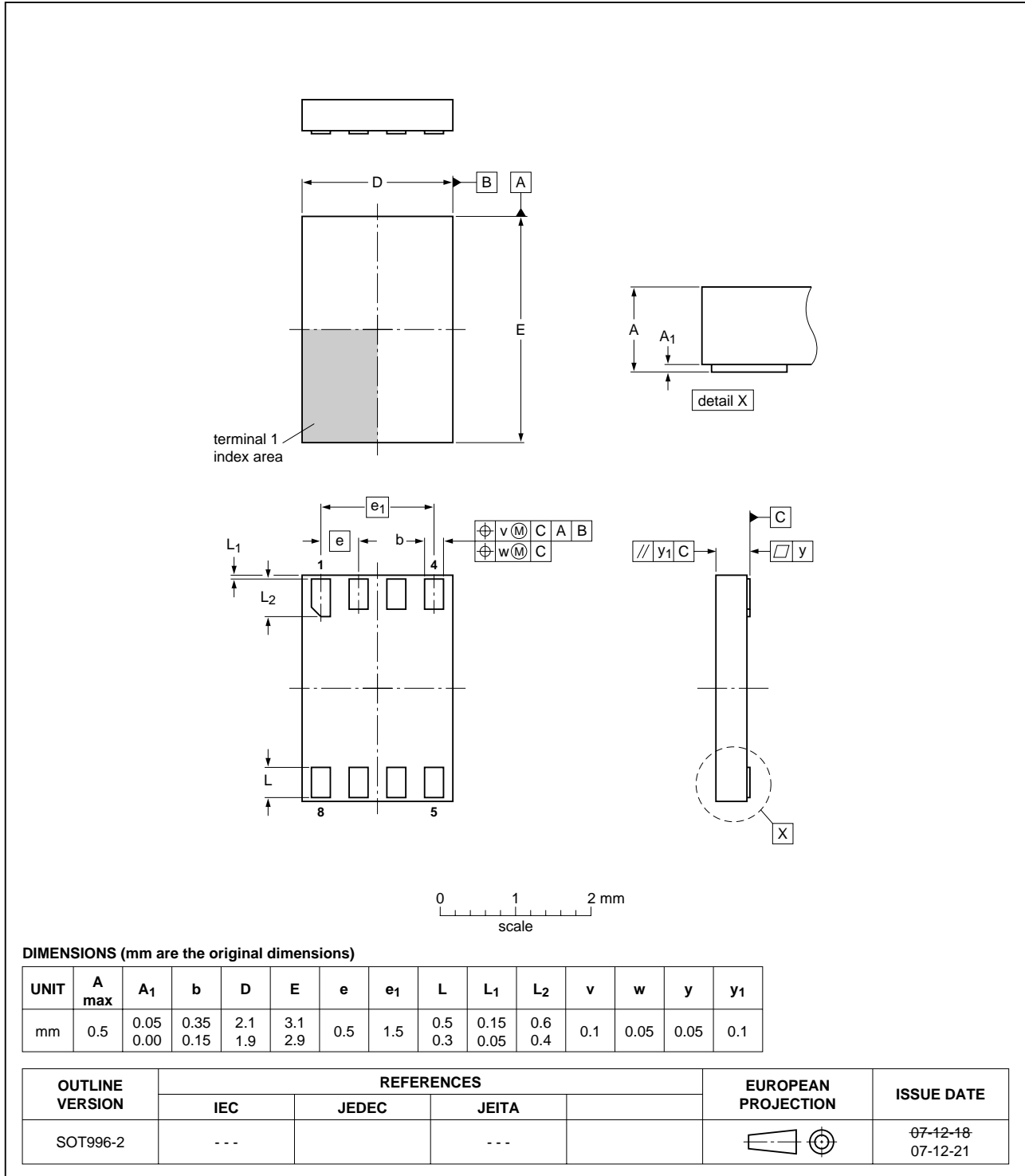

Fig 17. Package outline SOT996-2 (XSON8U)

16. Abbreviations

Table 13. Abbreviations

Acronym	Description
CMOS	Complementary Metal Oxide Semiconductor
DUT	Device Under Test
ESD	ElectroStatic Discharge
HBM	Human Body Model
MM	Machine Model
TTL	Transistor-Transistor Logic

17. Revision history

Table 14. Revision history

Document ID	Release date	Data sheet status	Change notice	Supersedes
74HC3GU04_3	20090511	Product data sheet	-	74HC3GU04_2
Modifications:	<ul style="list-style-type: none"> The format of this data sheet has been redesigned to comply with the new identity guidelines of NXP Semiconductors. Legal texts have been adapted to the new company name where appropriate. Added type number 74HC3GU04GD (XSON8U package) 			
74HC3GU04_2	20031126	Product specification	-	74HC3GU04_1
74HC3GU04_1	20030818	Product specification	-	-

18. Legal information

18.1 Data sheet status

Document status ^{[1][2]}	Product status ^[3]	Definition
Objective [short] data sheet	Development	This document contains data from the objective specification for product development.
Preliminary [short] data sheet	Qualification	This document contains data from the preliminary specification.
Product [short] data sheet	Production	This document contains the product specification.

[1] Please consult the most recently issued document before initiating or completing a design.

[2] The term 'short data sheet' is explained in section "Definitions".

[3] The product status of device(s) described in this document may have changed since this document was published and may differ in case of multiple devices. The latest product status information is available on the Internet at URL <http://www.nxp.com>.

18.2 Definitions

Draft — The document is a draft version only. The content is still under internal review and subject to formal approval, which may result in modifications or additions. NXP Semiconductors does not give any representations or warranties as to the accuracy or completeness of information included herein and shall have no liability for the consequences of use of such information.

Short data sheet — A short data sheet is an extract from a full data sheet with the same product type number(s) and title. A short data sheet is intended for quick reference only and should not be relied upon to contain detailed and full information. For detailed and full information see the relevant full data sheet, which is available on request via the local NXP Semiconductors sales office. In case of any inconsistency or conflict with the short data sheet, the full data sheet shall prevail.

18.3 Disclaimers

General — Information in this document is believed to be accurate and reliable. However, NXP Semiconductors does not give any representations or warranties, expressed or implied, as to the accuracy or completeness of such information and shall have no liability for the consequences of use of such information.

Right to make changes — NXP Semiconductors reserves the right to make changes to information published in this document, including without limitation specifications and product descriptions, at any time and without notice. This document supersedes and replaces all information supplied prior to the publication hereof.

Suitability for use — NXP Semiconductors products are not designed, authorized or warranted to be suitable for use in medical, military, aircraft, space or life support equipment, nor in applications where failure or malfunction of an NXP Semiconductors product can reasonably be expected to result in personal injury, death or severe property or environmental

damage. NXP Semiconductors accepts no liability for inclusion and/or use of NXP Semiconductors products in such equipment or applications and therefore such inclusion and/or use is at the customer's own risk.

Applications — Applications that are described herein for any of these products are for illustrative purposes only. NXP Semiconductors makes no representation or warranty that such applications will be suitable for the specified use without further testing or modification.

Limiting values — Stress above one or more limiting values (as defined in the Absolute Maximum Ratings System of IEC 60134) may cause permanent damage to the device. Limiting values are stress ratings only and operation of the device at these or any other conditions above those given in the Characteristics sections of this document is not implied. Exposure to limiting values for extended periods may affect device reliability.

Terms and conditions of sale — NXP Semiconductors products are sold subject to the general terms and conditions of commercial sale, as published at <http://www.nxp.com/profile/terms>, including those pertaining to warranty, intellectual property rights infringement and limitation of liability, unless explicitly otherwise agreed to in writing by NXP Semiconductors. In case of any inconsistency or conflict between information in this document and such terms and conditions, the latter will prevail.

No offer to sell or license — Nothing in this document may be interpreted or construed as an offer to sell products that is open for acceptance or the grant, conveyance or implication of any license under any copyrights, patents or other industrial or intellectual property rights.

Export control — This document as well as the item(s) described herein may be subject to export control regulations. Export might require a prior authorization from national authorities.

18.4 Trademarks

Notice: All referenced brands, product names, service names and trademarks are the property of their respective owners.

19. Contact information

For more information, please visit: <http://www.nxp.com>

For sales office addresses, please send an email to: salesaddresses@nxp.com

20. Contents

1	General description	1
2	Features	1
3	Ordering information	1
4	Marking	1
5	Functional diagram	2
6	Pinning information	2
6.1	Pinning	2
6.2	Pin description	2
7	Functional description	3
8	Limiting values	3
9	Recommended operating conditions	3
10	Static characteristics	4
11	Dynamic characteristics	4
12	Waveforms	5
12.1	Additional characteristics	7
13	Typical transfer characteristics	8
14	Application information	8
15	Package outline	11
16	Abbreviations	14
17	Revision history	14
18	Legal information	15
18.1	Data sheet status	15
18.2	Definitions	15
18.3	Disclaimers	15
18.4	Trademarks	15
19	Contact information	15
20	Contents	16

Please be aware that important notices concerning this document and the product(s) described herein, have been included in section 'Legal information'.



© NXP B.V. 2009.

All rights reserved.

For more information, please visit: <http://www.nxp.com>

For sales office addresses, please send an email to: salesaddresses@nxp.com

Date of release: 11 May 2009

Document identifier: 74HC3GU04_3