

74AUP1Z125

Low-power X-tal driver with enable and internal resistor

Rev. 02 — 7 August 2008

Product data sheet

1. General description

The 74AUP1Z125 combines the functions of the 74AUP1GU04 and 74AUP1G125 with enable circuitry and an internal bias resistor to provide a device optimized for use in crystal oscillator applications.

When not in use the $\overline{\text{EN}}$ input can be driven HIGH, pulling up the X1 input and putting the device in a low power disable mode. Schmitt trigger action at the $\overline{\text{EN}}$ input makes the circuit tolerant to slower input rise and fall times across the entire V_{CC} range from 0.8 V to 3.6 V.

This device is fully specified for partial power-down applications using I_{OFF} at output Y. The I_{OFF} circuitry disables the output Y, preventing the damaging backflow current through the device when it is powered down.

The integration of the two devices into the 74AUP1Z125 produces the benefits of a compact footprint, lower power dissipation and stable operation over a wide range of frequency and temperature.

2. Features

- Wide supply voltage range from 0.8 V to 3.6 V
- High noise immunity
- ESD protection:
 - ◆ HBM JESD22-A114E Class 3A exceeds 5000 V
 - ◆ MM JESD22-A115-A exceeds 200 V
 - ◆ CDM JESD22-C101C exceeds 1000 V
- Latch-up performance exceeds 100 mA per JESD 78 Class II
- Inputs accept voltages up to 3.6 V
- Low noise overshoot and undershoot < 10 % of V_{CC}
- I_{OFF} circuitry provides partial Power-down mode operation at output Y
- Multiple package options
- Specified from $-40\text{ }^{\circ}\text{C}$ to $+85\text{ }^{\circ}\text{C}$ and $-40\text{ }^{\circ}\text{C}$ to $+125\text{ }^{\circ}\text{C}$

3. Ordering information

Table 1. Ordering information

Type number	Package			Version
	Temperature range	Name	Description	
74AUP1Z125GW	-40 °C to +125 °C	SC-88	plastic surface-mounted package; 6 leads	SOT363
74AUP1Z125GM	-40 °C to +125 °C	XSON6	plastic extremely thin small outline package; no leads; 6 terminals; body 1 × 1.45 × 0.5 mm	SOT886
74AUP1Z125GF	-40 °C to +125 °C	XSON6	plastic extremely thin small outline package; no leads; 6 terminals; body 1 × 1 × 0.5 mm	SOT891

4. Marking

Table 2. Marking

Type number	Marking code
74AUP1Z125GW	55
74AUP1Z125GM	55
74AUP1Z125GF	55

5. Functional diagram

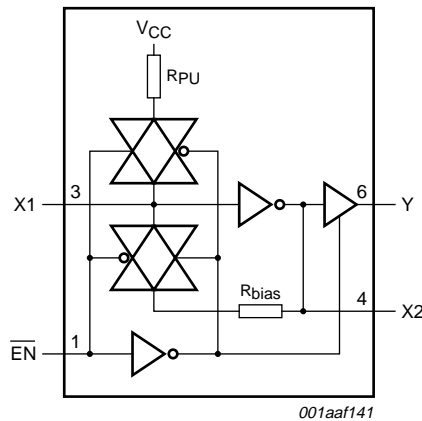

R_{PU} = pull-up resistance.

R_{bias} = bias resistance.

Fig 1. Logic symbol

6. Pinning information

6.1 Pinning

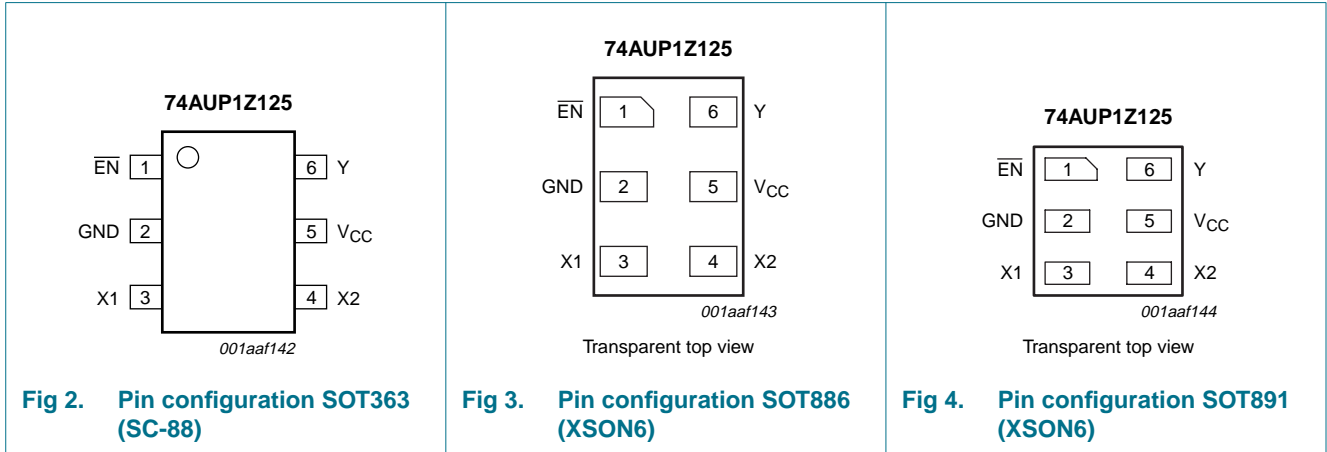

6.2 Pin description

Table 3. Pin description

Symbol	Pin	Description
$\overline{\text{EN}}$	1	enable input (active LOW)
GND	2	ground (0 V)
X1	3	data input
X2	4	unbuffered output
V _{CC}	5	supply voltage
Y	6	data output

7. Functional description

Table 4. Function table^[1]

Input		Output		
$\overline{\text{EN}}$	X1	X2	Y	
L	L	H	H	
L	H	L	L	
H	L	H	Z	
H	H	L	Z	

[1] H = HIGH voltage level;
 L = LOW voltage level;
 Z = high-impedance OFF-state.

8. Limiting values

Table 5. Limiting values

In accordance with the Absolute Maximum Rating System (IEC 60134). Voltages are referenced to GND (ground = 0 V).

Symbol	Parameter	Conditions	Min	Max	Unit
V_{CC}	supply voltage		-0.5	+4.6	V
I_{IK}	input clamping current	$V_I < 0$ V	-50	-	mA
V_I	input voltage		[1] -0.5	+4.6	V
I_{OK}	output clamping current	$V_O < 0$ V	-50	-	mA
V_O	output voltage	Active mode and Power-down mode	[1] -0.5	+4.6	V
I_O	output current	$V_O = 0$ V to V_{CC}	-	± 20	mA
I_{CC}	supply current		-	50	mA
I_{GND}	ground current		-50	-	mA
T_{stg}	storage temperature		-65	+150	°C
P_{tot}	total power dissipation	$T_{amb} = -40$ °C to +125 °C	[2] -	250	mW

[1] The input and output voltage ratings may be exceeded if the input and output current ratings are observed.

[2] For SC-88 packages: above 87.5 °C the value of P_{tot} derates linearly with 4.0 mW/K.
 For XSON6 packages: above 45 °C the value of P_{tot} derates linearly with 2.4 mW/K.

9. Recommended operating conditions

Table 6. Recommended operating conditions

Symbol	Parameter	Conditions	Min	Max	Unit
V_{CC}	supply voltage		0.8	3.6	V
V_I	input voltage		0	3.6	V
V_O	output voltage		0	V_{CC}	V
T_{amb}	ambient temperature		-40	+125	°C
$\Delta t/\Delta V$	input transition rise and fall rate	$V_{CC} = 0.8$ V to 3.6 V	-	200	ns/V

10. Static characteristics

Table 7. Static characteristics

At recommended operating conditions; voltages are referenced to GND (ground = 0 V).

Symbol	Parameter	Conditions	Min	Typ	Max	Unit
T_{amb} = 25 °C						
V _{IH}	HIGH-level input voltage	X1 input				
		V _{CC} = 0.8 V to 3.6 V	0.75 × V _{CC}	-	-	V
		$\overline{\text{EN}}$ input				
		V _{CC} = 0.8 V	0.70 × V _{CC}	-	-	V
		V _{CC} = 0.9 V to 1.95 V	0.65 × V _{CC}	-	-	V
		V _{CC} = 2.3 V to 2.7 V	1.6	-	-	V
		V _{CC} = 3.0 V to 3.6 V	2.0	-	-	V
V _{IL}	LOW-level input voltage	X1 input				
		V _{CC} = 0.8 V to 3.6 V	-	-	0.25 × V _{CC}	V
		$\overline{\text{EN}}$ input				
		V _{CC} = 0.8 V	-	-	0.30 × V _{CC}	V
		V _{CC} = 0.9 V to 1.95 V	-	-	0.35 × V _{CC}	V
		V _{CC} = 2.3 V to 2.7 V	-	-	0.7	V
		V _{CC} = 3.0 V to 3.6 V	-	-	0.9	V
V _{OH}	HIGH-level output voltage	Y output; V _I at X1 input = V _{IH} or V _{IL}				
		I _O = -20 μA; V _{CC} = 0.8 V to 3.6 V	V _{CC} - 0.1	-	-	V
		I _O = -1.1 mA; V _{CC} = 1.1 V	0.75 × V _{CC}	-	-	V
		I _O = -1.7 mA; V _{CC} = 1.4 V	1.11	-	-	V
		I _O = -1.9 mA; V _{CC} = 1.65 V	1.32	-	-	V
		I _O = -2.3 mA; V _{CC} = 2.3 V	2.05	-	-	V
		I _O = -3.1 mA; V _{CC} = 2.3 V	1.9	-	-	V
		I _O = -2.7 mA; V _{CC} = 3.0 V	2.72	-	-	V
		I _O = -4.0 mA; V _{CC} = 3.0 V	2.6	-	-	V
		X2 output; V _I = GND or V _{CC}				
		I _O = -20 μA; V _{CC} = 0.8 V to 3.6 V	V _{CC} - 0.1	-	-	V
		I _O = -1.1 mA; V _{CC} = 1.1 V	0.75 × V _{CC}	-	-	V
		I _O = -1.7 mA; V _{CC} = 1.4 V	1.11	-	-	V
		I _O = -1.9 mA; V _{CC} = 1.65 V	1.32	-	-	V
		I _O = -2.3 mA; V _{CC} = 2.3 V	2.05	-	-	V
		I _O = -3.1 mA; V _{CC} = 2.3 V	1.9	-	-	V
		I _O = -2.7 mA; V _{CC} = 3.0 V	2.72	-	-	V
I _O = -4.0 mA; V _{CC} = 3.0 V	2.6	-	-	V		

Table 7. Static characteristics ...continued

At recommended operating conditions; voltages are referenced to GND (ground = 0 V).

Symbol	Parameter	Conditions	Min	Typ	Max	Unit	
V _{OL}	LOW-level output voltage	Y output; V _I at X1 input = V _{IH} or V _{IL}					
		I _O = 20 μA; V _{CC} = 0.8 V to 3.6 V	-	-	0.1	V	
		I _O = 1.1 mA; V _{CC} = 1.1 V	-	-	0.3 × V _{CC}	V	
		I _O = 1.7 mA; V _{CC} = 1.4 V	-	-	0.31	V	
		I _O = 1.9 mA; V _{CC} = 1.65 V	-	-	0.31	V	
		I _O = 2.3 mA; V _{CC} = 2.3 V	-	-	0.31	V	
		I _O = 3.1 mA; V _{CC} = 2.3 V	-	-	0.44	V	
		I _O = 2.7 mA; V _{CC} = 3.0 V	-	-	0.31	V	
		I _O = 4.0 mA; V _{CC} = 3.0 V	-	-	0.44	V	
		X2 output; V _I = GND or V _{CC}					
		I _O = 20 μA; V _{CC} = 0.8 V to 3.6 V	-	-	0.1	V	
		I _O = 1.1 mA; V _{CC} = 1.1 V	-	-	0.3 × V _{CC}	V	
		I _O = 1.7 mA; V _{CC} = 1.4 V	-	-	0.31	V	
		I _O = 1.9 mA; V _{CC} = 1.65 V	-	-	0.31	V	
		I _O = 2.3 mA; V _{CC} = 2.3 V	-	-	0.31	V	
		I _O = 3.1 mA; V _{CC} = 2.3 V	-	-	0.44	V	
		I _O = 2.7 mA; V _{CC} = 3.0 V	-	-	0.31	V	
		I _O = 4.0 mA; V _{CC} = 3.0 V	-	-	0.44	V	
I _I	input leakage current	X1 input					
		V _I = $\overline{\text{EN}}$ = V _{CC} ; V _{CC} = 0 V to 3.6 V	-	-	±0.1	μA	
		$\overline{\text{EN}}$ input					
		V _I = GND to 3.6 V; V _{CC} = 0 V to 3.6 V	-	-	±0.1	μA	
I _{pu}	pull-up current	X1 input; $\overline{\text{EN}}$ = V _{CC}					
		V _I = GND; V _{CC} = 0.8 V to 3.6 V	-	-	15	μA	
I _{OZ}	OFF-state output current	Y output; V _O = 0 V to 3.6 V; V _{CC} = 0 V to 3.6 V; $\overline{\text{EN}}$ = V _{CC}	-	-	±0.1	μA	
I _{OFF}	power-off leakage current	V _I or V _O = 0 V to 3.6 V; V _{CC} = 0 V	[1]	-	±0.2	μA	
ΔI _{OFF}	additional power-off leakage current	V _I or V _O = 0 V to 3.6 V; V _{CC} = 0 V to 0.2 V	[1]	-	±0.2	μA	
I _{CC}	supply current	V _I = GND or V _{CC} ; I _O = 0 A; V _{CC} = 0.8 V to 3.6 V	-	-	75	μA	
ΔI _{CC}	additional supply current	$\overline{\text{EN}}$ input					
		V _I = V _{CC} - 0.6 V; I _O = 0 A; V _{CC} = 3.3 V	-	-	40	μA	
C _I	input capacitance	X1 input					
		V _{CC} = 0 V to 3.6 V; V _I = GND or V _{CC}	-	1.3	-	pF	
		$\overline{\text{EN}}$ input					
		V _{CC} = 0 V to 3.6 V; V _I = GND or V _{CC}	-	0.8	-	pF	

Table 7. Static characteristics ...continued

At recommended operating conditions; voltages are referenced to GND (ground = 0 V).

Symbol	Parameter	Conditions	Min	Typ	Max	Unit
C _O	output capacitance	X2 output				
		V _O = GND; V _{CC} = 0 V	-	1.5	-	pF
		Y output				
		V _O = GND; V _{CC} = 0 V	-	1.7	-	pF
g _{fs}	forward transconductance	see Figure 10 and Figure 11				
		V _{CC} = 0.8 V	-	-	-	mA/V
		V _{CC} = 1.1 V to 1.3 V	0.2	-	9.9	mA/V
		V _{CC} = 1.4 V to 1.6 V	3.9	-	17.7	mA/V
		V _{CC} = 1.65 V to 1.95 V	7.9	-	24.3	mA/V
		V _{CC} = 2.3 V to 2.7 V	18	-	30.7	mA/V
		V _{CC} = 3.0 V to 3.6 V	20.5	-	32.4	mA/V
R _{bias}	bias resistance	$\overline{\text{EN}}$ = GND; f _i = 0 Hz; V _I = 0 V or V _{CC} ; See Figure 5 ; for frequency behavior see Figure 6	1.08	1.62	3.08	MΩ
T_{amb} = -40 °C to +85 °C						
V _{IH}	HIGH-level input voltage	X1 input				
		V _{CC} = 0.8 V to 3.6 V	0.75 × V _{CC}	-	-	V
		$\overline{\text{EN}}$ input				
		V _{CC} = 0.8 V	0.70 × V _{CC}	-	-	V
		V _{CC} = 0.9 V to 1.95 V	0.65 × V _{CC}	-	-	V
		V _{CC} = 2.3 V to 2.7 V	1.6	-	-	V
V _{IL}	LOW-level input voltage	X1 input				
		V _{CC} = 0.8 V to 3.6 V	-	-	0.25 × V _{CC}	V
		$\overline{\text{EN}}$ input				
		V _{CC} = 0.8 V	-	-	0.30 × V _{CC}	V
		V _{CC} = 0.9 V to 1.95 V	-	-	0.35 × V _{CC}	V
		V _{CC} = 2.3 V to 2.7 V	-	-	0.7	V
		V _{CC} = 3.0 V to 3.6 V	-	-	0.9	V

Table 7. Static characteristics ...continued

At recommended operating conditions; voltages are referenced to GND (ground = 0 V).

Symbol	Parameter	Conditions	Min	Typ	Max	Unit		
V _{OH}	HIGH-level output voltage	Y output; V _I at X1 input = V _{IH} or V _{IL}						
		I _O = -20 μA; V _{CC} = 0.8 V to 3.6 V	V _{CC} - 0.1	-	-	V		
		I _O = -1.1 mA; V _{CC} = 1.1 V	0.7 × V _{CC}	-	-	V		
		I _O = -1.7 mA; V _{CC} = 1.4 V	1.03	-	-	V		
		I _O = -1.9 mA; V _{CC} = 1.65 V	1.30	-	-	V		
		I _O = -2.3 mA; V _{CC} = 2.3 V	1.97	-	-	V		
		I _O = -3.1 mA; V _{CC} = 2.3 V	1.85	-	-	V		
		I _O = -2.7 mA; V _{CC} = 3.0 V	2.67	-	-	V		
		I _O = -4.0 mA; V _{CC} = 3.0 V	2.55	-	-	V		
		X2 output; V _I = GND or V _{CC}						
		I _O = -20 μA; V _{CC} = 0.8 V to 3.6 V	V _{CC} - 0.1	-	-	V		
		I _O = -1.1 mA; V _{CC} = 1.1 V	0.7 × V _{CC}	-	-	V		
		I _O = -1.7 mA; V _{CC} = 1.4 V	1.03	-	-	V		
		I _O = -1.9 mA; V _{CC} = 1.65 V	1.30	-	-	V		
		I _O = -2.3 mA; V _{CC} = 2.3 V	1.97	-	-	V		
		I _O = -3.1 mA; V _{CC} = 2.3 V	1.85	-	-	V		
		I _O = -2.7 mA; V _{CC} = 3.0 V	2.67	-	-	V		
		I _O = -4.0 mA; V _{CC} = 3.0 V	2.55	-	-	V		
		V _{OL}	LOW-level output voltage	Y output; V _I at X1 input = V _{IH} or V _{IL}				
				I _O = 20 μA; V _{CC} = 0.8 V to 3.6 V	-	-	0.1	V
I _O = 1.1 mA; V _{CC} = 1.1 V	-			-	0.3 × V _{CC}	V		
I _O = 1.7 mA; V _{CC} = 1.4 V	-			-	0.37	V		
I _O = 1.9 mA; V _{CC} = 1.65 V	-			-	0.35	V		
I _O = 2.3 mA; V _{CC} = 2.3 V	-			-	0.33	V		
I _O = 3.1 mA; V _{CC} = 2.3 V	-			-	0.45	V		
I _O = 2.7 mA; V _{CC} = 3.0 V	-			-	0.33	V		
I _O = 4.0 mA; V _{CC} = 3.0 V	-			-	0.45	V		
X2 output; V _I = GND or V _{CC}								
I _O = 20 μA; V _{CC} = 0.8 V to 3.6 V	-			-	0.1	V		
I _O = 1.1 mA; V _{CC} = 1.1 V	-			-	0.3 × V _{CC}	V		
I _O = 1.7 mA; V _{CC} = 1.4 V	-			-	0.37	V		
I _O = 1.9 mA; V _{CC} = 1.65 V	-			-	0.35	V		
I _O = 2.3 mA; V _{CC} = 2.3 V	-			-	0.33	V		
I _O = 3.1 mA; V _{CC} = 2.3 V	-			-	0.45	V		
I _O = 2.7 mA; V _{CC} = 3.0 V	-			-	0.33	V		
I _O = 4.0 mA; V _{CC} = 3.0 V	-			-	0.45	V		

Table 7. Static characteristics ...continued

At recommended operating conditions; voltages are referenced to GND (ground = 0 V).

Symbol	Parameter	Conditions	Min	Typ	Max	Unit
I_I	input leakage current	X1 input $V_I = \overline{EN} = V_{CC}; V_{CC} = 0 \text{ V to } 3.6 \text{ V}$	-	-	± 0.5	μA
		\overline{EN} input $V_I = \text{GND to } 3.6 \text{ V}; V_{CC} = 0 \text{ V to } 3.6 \text{ V}$	-	-	± 0.5	μA
I_{pu}	pull-up current	X1 input; $\overline{EN} = V_{CC}$ $V_I = \text{GND}; V_{CC} = 0.8 \text{ V to } 3.6 \text{ V}$	-	-	15	μA
I_{OZ}	OFF-state output current	Y output; $V_O = 0 \text{ V to } 3.6 \text{ V}; V_{CC} = 0 \text{ V to } 3.6 \text{ V}; \overline{EN} = V_{CC}$	-	-	± 0.5	μA
I_{OFF}	power-off leakage current	V_I or $V_O = 0 \text{ V to } 3.6 \text{ V}; V_{CC} = 0 \text{ V}$	[1]	-	± 0.5	μA
ΔI_{OFF}	additional power-off leakage current	V_I or $V_O = 0 \text{ V to } 3.6 \text{ V}; V_{CC} = 0 \text{ V to } 0.2 \text{ V}$	[1]	-	± 0.6	μA
I_{CC}	supply current	$V_I = \text{GND or } V_{CC}; I_O = 0 \text{ A}; V_{CC} = 0.8 \text{ V to } 3.6 \text{ V}$	-	-	75	μA
ΔI_{CC}	additional supply current	\overline{EN} input $V_I = V_{CC} - 0.6 \text{ V}; I_O = 0 \text{ A}; V_{CC} = 3.3 \text{ V}$	-	-	50	μA
g_{fs}	forward transconductance	see Figure 10 and Figure 11 $V_{CC} = 0.8 \text{ V}$	-	-	-	mA/V
		$V_{CC} = 1.1 \text{ V to } 1.3 \text{ V}$	-	-	10.8	mA/V
		$V_{CC} = 1.4 \text{ V to } 1.6 \text{ V}$	1.8	-	21.2	mA/V
		$V_{CC} = 1.65 \text{ V to } 1.95 \text{ V}$	7.5	-	29.9	mA/V
		$V_{CC} = 2.3 \text{ V to } 2.7 \text{ V}$	15.0	-	38.0	mA/V
		$V_{CC} = 3.0 \text{ V to } 3.6 \text{ V}$	17.8	-	39.2	mA/V
R_{bias}	bias resistance	$\overline{EN} = \text{GND}; f_i = 0 \text{ Hz}; V_I = 0 \text{ V or } V_{CC}$; See Figure 5 ; for frequency behavior see Figure 6	1.07	-	3.11	$\text{M}\Omega$

Table 7. Static characteristics ...continued

At recommended operating conditions; voltages are referenced to GND (ground = 0 V).

Symbol	Parameter	Conditions	Min	Typ	Max	Unit
T_{amb} = -40 °C to +125 °C						
V _{IH}	HIGH-level input voltage	X1 input				
		V _{CC} = 0.8 V to 3.6 V	0.75 × V _{CC}	-	-	V
		$\overline{\text{EN}}$ input				
		V _{CC} = 0.8 V	0.75 × V _{CC}	-	-	V
		V _{CC} = 0.9 V to 1.95 V	0.70 × V _{CC}	-	-	V
V _{IL}	LOW-level input voltage	X1 input				
		V _{CC} = 0.8 V to 3.6 V	-	-	0.25 × V _{CC}	V
		$\overline{\text{EN}}$ input				
		V _{CC} = 0.8 V	-	-	0.25 × V _{CC}	V
		V _{CC} = 0.9 V to 1.95 V	-	-	0.30 × V _{CC}	V
V _{OH}	HIGH-level output voltage	Y output; V _I at X1 input = V _{IH} or V _{IL}				
		I _O = -20 μA; V _{CC} = 0.8 V to 3.6 V	V _{CC} - 0.11	-	-	V
		I _O = -1.1 mA; V _{CC} = 1.1 V	0.6 × V _{CC}	-	-	V
		I _O = -1.7 mA; V _{CC} = 1.4 V	0.93	-	-	V
		I _O = -1.9 mA; V _{CC} = 1.65 V	1.17	-	-	V
		I _O = -2.3 mA; V _{CC} = 2.3 V	1.77	-	-	V
		I _O = -3.1 mA; V _{CC} = 2.3 V	1.67	-	-	V
		I _O = -2.7 mA; V _{CC} = 3.0 V	2.40	-	-	V
		I _O = -4.0 mA; V _{CC} = 3.0 V	2.30	-	-	V
		X2 output; V _I = GND or V _{CC}				
		I _O = -20 μA; V _{CC} = 0.8 V to 3.6 V	V _{CC} - 0.11	-	-	V
		I _O = -1.1 mA; V _{CC} = 1.1 V	0.6 × V _{CC}	-	-	V
		I _O = -1.7 mA; V _{CC} = 1.4 V	0.93	-	-	V
		I _O = -1.9 mA; V _{CC} = 1.65 V	1.17	-	-	V
		I _O = -2.3 mA; V _{CC} = 2.3 V	1.77	-	-	V
		I _O = -3.1 mA; V _{CC} = 2.3 V	1.67	-	-	V
		I _O = -2.7 mA; V _{CC} = 3.0 V	2.40	-	-	V
		I _O = -4.0 mA; V _{CC} = 3.0 V	2.30	-	-	V

Table 7. Static characteristics ...continued

At recommended operating conditions; voltages are referenced to GND (ground = 0 V).

Symbol	Parameter	Conditions	Min	Typ	Max	Unit	
V _{OL}	LOW-level output voltage	Y output; V _I = V _{IH} or V _{IL}					
		I _O = 20 μA; V _{CC} = 0.8 V to 3.6 V	-	-	0.11	V	
		I _O = 1.1 mA; V _{CC} = 1.1 V	-	-	0.33 × V _{CC}	V	
		I _O = 1.7 mA; V _{CC} = 1.4 V	-	-	0.41	V	
		I _O = 1.9 mA; V _{CC} = 1.65 V	-	-	0.39	V	
		I _O = 2.3 mA; V _{CC} = 2.3 V	-	-	0.36	V	
		I _O = 3.1 mA; V _{CC} = 2.3 V	-	-	0.50	V	
		I _O = 2.7 mA; V _{CC} = 3.0 V	-	-	0.36	V	
		I _O = 4.0 mA; V _{CC} = 3.0 V	-	-	0.50	V	
		X2 output; V _I = GND or V _{CC}					
		I _O = 20 μA; V _{CC} = 0.8 V to 3.6 V	-	-	0.11	V	
		I _O = 1.1 mA; V _{CC} = 1.1 V	-	-	0.33 × V _{CC}	V	
		I _O = 1.7 mA; V _{CC} = 1.4 V	-	-	0.41	V	
		I _O = 1.9 mA; V _{CC} = 1.65 V	-	-	0.39	V	
		I _O = 2.3 mA; V _{CC} = 2.3 V	-	-	0.36	V	
		I _O = 3.1 mA; V _{CC} = 2.3 V	-	-	0.50	V	
		I _O = 2.7 mA; V _{CC} = 3.0 V	-	-	0.36	V	
		I _O = 4.0 mA; V _{CC} = 3.0 V	-	-	0.50	V	
I _I	input leakage current	X1 input					
		V _I = $\overline{\text{EN}}$ = V _{CC} ; V _{CC} = 0 V to 3.6 V	-	-	±0.75	μA	
		$\overline{\text{EN}}$ input					
		V _I = GND to 3.6 V; V _{CC} = 0 V to 3.6 V	-	-	±0.75	μA	
I _{pu}	pull-up current	X1 input; $\overline{\text{EN}}$ = V _{CC}					
		V _I = GND; V _{CC} = 0.8 V to 3.6 V	-	-	15	μA	
I _{OZ}	OFF-state output current	Y output; V _O = 0 V to 3.6 V; V _{CC} = 0 V to 3.6 V; $\overline{\text{EN}}$ = V _{CC}	-	-	±0.75	μA	
I _{OFF}	power-off leakage current	V _I or V _O = 0 V to 3.6 V; V _{CC} = 0 V	[1]	-	±0.75	μA	
ΔI _{OFF}	additional power-off leakage current	V _I or V _O = 0 V to 3.6 V; V _{CC} = 0 V to 0.2 V	[1]	-	±0.75	μA	
I _{CC}	supply current	V _I = GND or V _{CC} ; I _O = 0 A; V _{CC} = 0.8 V to 3.6 V	-	-	75	μA	
ΔI _{CC}	additional supply current	$\overline{\text{EN}}$ input					
		V _I = V _{CC} - 0.6 V; I _O = 0 A; V _{CC} = 3.3 V	-	-	75	μA	

Table 7. Static characteristics ...continued

At recommended operating conditions; voltages are referenced to GND (ground = 0 V).

Symbol	Parameter	Conditions	Min	Typ	Max	Unit
g _{fs}	forward transconductance	see Figure 10 and Figure 11				
		V _{CC} = 0.8 V	-	-	-	mA/V
		V _{CC} = 1.1 V to 1.3 V	-	-	10.8	mA/V
		V _{CC} = 1.4 V to 1.6 V	1.8	-	21.2	mA/V
		V _{CC} = 1.65 V to 1.95 V	6.9	-	29.9	mA/V
		V _{CC} = 2.3 V to 2.7 V	13.4	-	38.0	mA/V
		V _{CC} = 3.0 V to 3.6 V	15.8	-	39.2	mA/V
R _{bias}	bias resistance	$\overline{EN} = \text{GND}$; f _i = 0 Hz; V _I = 0 V or V _{CC} ; See Figure 5 ; for frequency behavior see Figure 6	1.07	-	3.11	MΩ

[1] Only for output Y and input \overline{EN} .

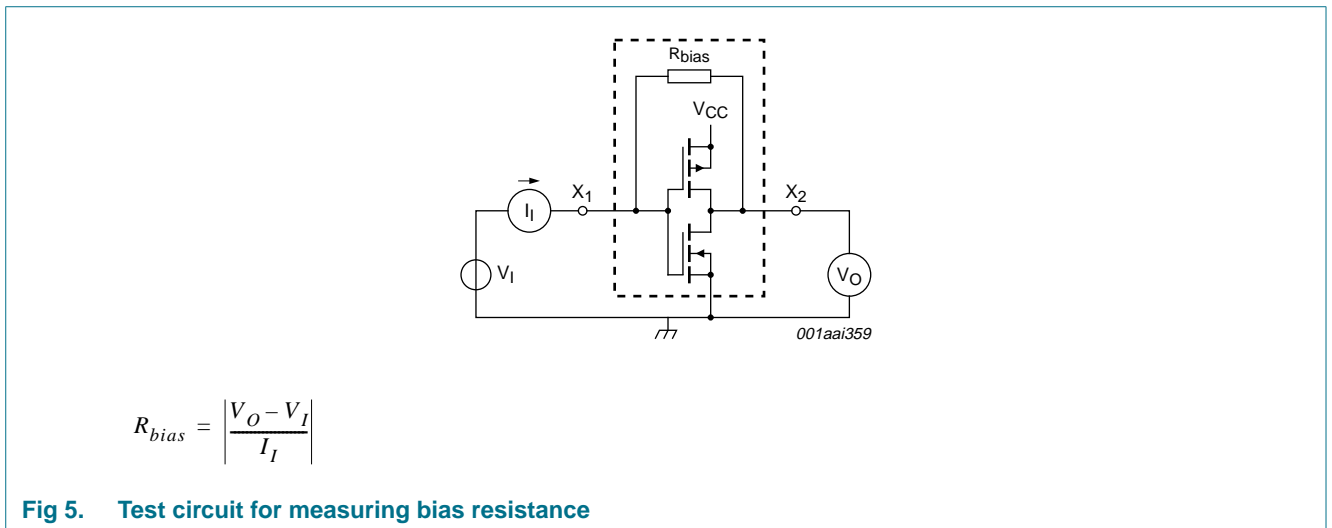

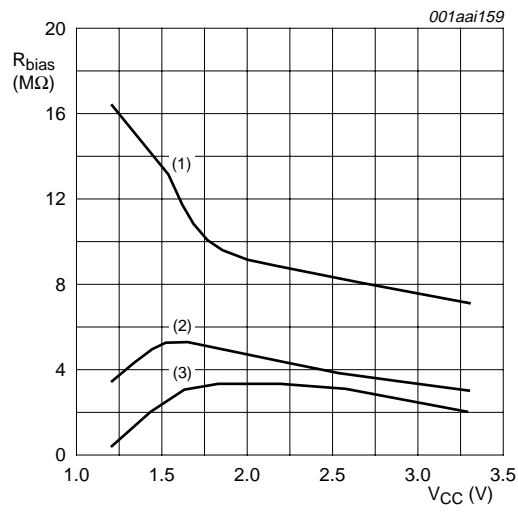

- (1) $f_i = 30 \text{ kHz}$.
- (2) $f_i = 1 \text{ MHz}$.
- (3) $f_i = 10 \text{ MHz}$.

Fig 6. Typical bias resistance versus supply voltage

11. Dynamic characteristics

Table 8. Dynamic characteristics

Voltages are referenced to GND (ground = 0 V); for test circuit see [Figure 9](#).

Symbol	Parameter	Conditions	25 °C			-40 °C to +125 °C			Unit
			Min	Typ ^[1]	Max	Min	Max (85 °C)	Max (125 °C)	
C_L = 5 pF									
t _{pd}	propagation delay	X1 to X2; see Figure 7	[2]						
		V _{CC} = 0.8 V	-	6.2	-	-	-	-	ns
		V _{CC} = 1.1 V to 1.3 V	0.9	2.3	4.4	0.9	4.8	5.3	ns
		V _{CC} = 1.4 V to 1.6 V	0.7	1.7	3.1	0.6	3.4	3.8	ns
		V _{CC} = 1.65 V to 1.95 V	0.5	1.4	2.6	0.5	2.9	3.2	ns
		V _{CC} = 2.3 V to 2.7 V	0.4	1.1	2.0	0.4	2.3	2.6	ns
		V _{CC} = 3.0 V to 3.6 V	0.3	1.0	1.8	0.3	2.1	2.4	ns
		X1 to Y; see Figure 7	[2]						
		V _{CC} = 0.8 V	-	18.5	-	-	-	-	ns
		V _{CC} = 1.1 V to 1.3 V	2.8	5.9	12.5	3.2	14.8	16.3	ns
		V _{CC} = 1.4 V to 1.6 V	2.2	4.2	7.7	2.6	9.1	10.1	ns
		V _{CC} = 1.65 V to 1.95 V	1.9	3.5	6.2	2.2	7.8	8.6	ns
		V _{CC} = 2.3 V to 2.7 V	1.6	2.9	4.8	1.9	6.2	6.9	ns
		V _{CC} = 3.0 V to 3.6 V	1.4	2.6	4.1	1.7	4.7	5.2	ns
t _{en}	enable time	$\overline{\text{EN}}$ to Y; see Figure 8	[3]						
		V _{CC} = 0.8 V	-	31.2	-	-	-	-	ns
		V _{CC} = 1.1 V to 1.3 V	3.1	6.1	13.8	2.9	16.3	18.0	ns
		V _{CC} = 1.4 V to 1.6 V	2.5	4.3	8.2	2.3	9.7	10.7	ns
		V _{CC} = 1.65 V to 1.95 V	2.1	3.6	6.5	2.0	7.6	8.4	ns
		V _{CC} = 2.3 V to 2.7 V	1.8	2.9	4.8	1.7	5.8	6.4	ns
		V _{CC} = 3.0 V to 3.6 V	1.7	2.6	4.1	1.7	4.7	5.2	ns
t _{dis}	disable time	$\overline{\text{EN}}$ to Y; see Figure 8	[4]						
		V _{CC} = 0.8 V	-	11.1	-	-	-	-	ns
		V _{CC} = 1.1 V to 1.3 V	2.5	4.5	9.0	2.9	9.4	10.4	ns
		V _{CC} = 1.4 V to 1.6 V	2.0	3.3	6.4	2.3	6.7	7.4	ns
		V _{CC} = 1.65 V to 1.95 V	1.9	3.2	6.0	2.0	6.4	7.1	ns
		V _{CC} = 2.3 V to 2.7 V	1.4	2.3	4.4	1.7	4.7	5.2	ns
		V _{CC} = 3.0 V to 3.6 V	1.7	2.6	4.4	1.7	4.9	5.4	ns

Table 8. Dynamic characteristics ...continued
 Voltages are referenced to GND (ground = 0 V); for test circuit see [Figure 9](#).

Symbol	Parameter	Conditions	25 °C			–40 °C to +125 °C			Unit
			Min	Typ ^[1]	Max	Min	Max (85 °C)	Max (125 °C)	
C_L = 10 pF									
t _{pd}	propagation delay	X1 to X2; see Figure 7	[2]						
		V _{CC} = 0.8 V	-	9.6	-	-	-	-	ns
		V _{CC} = 1.1 V to 1.3 V	1.2	3.1	6.1	1.2	6.8	7.5	ns
		V _{CC} = 1.4 V to 1.6 V	1.0	2.3	4.0	0.9	4.6	5.1	ns
		V _{CC} = 1.65 V to 1.95 V	0.8	1.9	3.3	0.7	3.8	4.2	ns
		V _{CC} = 2.3 V to 2.7 V	0.6	1.5	2.7	0.6	3.1	3.5	ns
		V _{CC} = 3.0 V to 3.6 V	0.5	1.3	2.4	0.5	2.7	3.0	ns
		X1 to Y; see Figure 7	[2]						
		V _{CC} = 0.8 V	-	21.4	-	-	-	-	ns
		V _{CC} = 1.1 V to 1.3 V	3.2	6.7	14.3	3.6	16.2	17.9	ns
		V _{CC} = 1.4 V to 1.6 V	2.1	4.9	8.9	3.0	10.1	11.2	ns
		V _{CC} = 1.65 V to 1.95 V	1.9	4.1	6.9	2.6	8.0	8.8	ns
		V _{CC} = 2.3 V to 2.7 V	2.1	3.4	5.4	2.3	6.6	7.3	ns
		V _{CC} = 3.0 V to 3.6 V	1.8	3.1	4.8	2.1	5.6	6.2	ns
t _{en}	enable time	$\overline{\text{EN}}$ to Y; see Figure 8	[3]						
		V _{CC} = 0.8 V	-	34.4	-	-	-	-	ns
		V _{CC} = 1.1 V to 1.3 V	3.6	6.9	15.5	3.4	16.0	17.6	ns
		V _{CC} = 1.4 V to 1.6 V	2.3	5.0	9.3	2.2	9.6	10.6	ns
		V _{CC} = 1.65 V to 1.95 V	2.0	4.2	7.2	1.9	7.9	8.7	ns
		V _{CC} = 2.3 V to 2.7 V	1.8	3.4	5.5	1.7	6.4	7.1	ns
		V _{CC} = 3.0 V to 3.6 V	1.7	3.2	4.9	1.7	5.5	6.1	ns
t _{dis}	disable time	$\overline{\text{EN}}$ to Y; see Figure 8	[4]						
		V _{CC} = 0.8 V	-	13.0	-	-	-	-	ns
		V _{CC} = 1.1 V to 1.3 V	3.4	5.7	10.4	3.4	10.8	11.9	ns
		V _{CC} = 1.4 V to 1.6 V	2.1	4.2	7.6	2.2	8.0	8.8	ns
		V _{CC} = 1.65 V to 1.95 V	2.2	4.3	7.3	1.9	7.6	8.4	ns
		V _{CC} = 2.3 V to 2.7 V	1.6	3.1	5.3	1.7	5.5	6.1	ns
		V _{CC} = 3.0 V to 3.6 V	2.1	3.8	6.0	1.7	6.5	7.2	ns

Table 8. Dynamic characteristics ...continuedVoltages are referenced to GND (ground = 0 V); for test circuit see [Figure 9](#).

Symbol	Parameter	Conditions	25 °C			–40 °C to +125 °C			Unit
			Min	Typ ^[1]	Max	Min	Max (85 °C)	Max (125 °C)	
C_L = 15 pF									
t _{pd}	propagation delay	X1 to X2; see Figure 7	[2]						
		V _{CC} = 0.8 V	-	13.0	-	-	-	-	ns
		V _{CC} = 1.1 V to 1.3 V	1.6	3.8	7.9	1.4	8.8	9.7	ns
		V _{CC} = 1.4 V to 1.6 V	1.3	2.8	4.9	1.1	5.7	6.3	ns
		V _{CC} = 1.65 V to 1.95 V	1.0	2.3	4.0	0.9	4.7	5.2	ns
		V _{CC} = 2.3 V to 2.7 V	0.8	1.9	3.2	0.8	3.7	4.1	ns
		V _{CC} = 3.0 V to 3.6 V	0.7	1.6	2.9	0.7	3.3	3.7	ns
		X1 to Y; see Figure 7	[2]						
		V _{CC} = 0.8 V	-	24.2	-	-	-	-	ns
		V _{CC} = 1.1 V to 1.3 V	3.6	7.5	16.1	4.0	17.6	19.4	ns
		V _{CC} = 1.4 V to 1.6 V	3.0	5.4	9.7	3.3	10.6	11.7	ns
		V _{CC} = 1.65 V to 1.95 V	2.2	4.6	7.7	2.9	9.0	9.9	ns
		V _{CC} = 2.3 V to 2.7 V	2.0	3.9	6.1	2.6	7.3	8.1	ns
		V _{CC} = 3.0 V to 3.6 V	2.0	3.6	5.4	2.3	5.9	6.5	ns
t _{en}	enable time	$\overline{\text{EN}}$ to Y; see Figure 8	[3]						
		V _{CC} = 0.8 V	-	37.5	-	-	-	-	ns
		V _{CC} = 1.1 V to 1.3 V	4.0	7.7	17.2	3.7	17.5	19.3	ns
		V _{CC} = 1.4 V to 1.6 V	3.0	5.5	10.0	2.5	10.2	11.3	ns
		V _{CC} = 1.65 V to 1.95 V	2.3	4.7	7.9	2.1	9.2	10.2	ns
		V _{CC} = 2.3 V to 2.7 V	2.0	3.9	6.2	2.0	7.4	8.2	ns
		V _{CC} = 3.0 V to 3.6 V	2.0	3.6	5.5	1.9	6.0	6.6	ns
t _{dis}	disable time	$\overline{\text{EN}}$ to Y; see Figure 8	[4]						
		V _{CC} = 0.8 V	-	14.8	-	-	-	-	ns
		V _{CC} = 1.1 V to 1.3 V	4.3	6.8	11.2	3.7	12.4	13.7	ns
		V _{CC} = 1.4 V to 1.6 V	3.0	5.1	8.1	2.5	8.9	9.8	ns
		V _{CC} = 1.65 V to 1.95 V	3.0	5.4	8.0	2.1	9.3	10.3	ns
		V _{CC} = 2.3 V to 2.7 V	2.1	3.9	6.1	2.0	7.3	8.1	ns
		V _{CC} = 3.0 V to 3.6 V	2.9	5.1	7.2	1.9	7.9	8.7	ns

Table 8. Dynamic characteristics ...continued
 Voltages are referenced to GND (ground = 0 V); for test circuit see [Figure 9](#).

Symbol	Parameter	Conditions	25 °C			–40 °C to +125 °C			Unit
			Min	Typ ^[1]	Max	Min	Max (85 °C)	Max (125 °C)	
C_L = 30 pF									
t _{pd}	propagation delay	X1 to X2; see Figure 7	[2]						
		V _{CC} = 0.8 V	-	23.2	-	-	-	-	ns
		V _{CC} = 1.1 V to 1.3 V	2.4	6.0	13.1	2.2	14.8	16.3	ns
		V _{CC} = 1.4 V to 1.6 V	2.0	4.2	7.6	1.8	9.0	9.9	ns
		V _{CC} = 1.65 V to 1.95 V	1.7	3.6	6.1	1.5	7.2	8.0	ns
		V _{CC} = 2.3 V to 2.7 V	1.4	2.9	4.8	1.3	5.7	6.3	ns
		V _{CC} = 3.0 V to 3.6 V	1.2	2.5	4.3	1.1	5.1	5.7	ns
		X1 to Y; see Figure 7	[2]						
		V _{CC} = 0.8 V	-	32.6	-	-	-	-	ns
		V _{CC} = 1.1 V to 1.3 V	4.8	9.6	21.0	5.0	21.7	23.9	ns
		V _{CC} = 1.4 V to 1.6 V	4.0	6.9	12.4	4.3	13.5	14.9	ns
		V _{CC} = 1.65 V to 1.95 V	2.9	5.9	9.8	3.8	10.7	11.8	ns
		V _{CC} = 2.3 V to 2.7 V	2.7	5.0	7.5	3.3	8.2	9.1	ns
		V _{CC} = 3.0 V to 3.6 V	2.7	4.7	6.8	3.1	7.7	8.5	ns
t _{en}	enable time	$\overline{\text{EN}}$ to Y; see Figure 8	[3]						
		V _{CC} = 0.8 V	-	47.1	-	-	-	-	ns
		V _{CC} = 1.1 V to 1.3 V	5.2	9.9	21.0	4.8	21.7	23.9	ns
		V _{CC} = 1.4 V to 1.6 V	4.0	7.1	12.4	3.1	13.5	14.9	ns
		V _{CC} = 1.65 V to 1.95 V	3.0	6.0	9.9	2.8	10.7	11.8	ns
		V _{CC} = 2.3 V to 2.7 V	2.7	5.0	7.7	2.6	8.1	9.0	ns
		V _{CC} = 3.0 V to 3.6 V	2.7	4.8	6.8	2.6	7.7	8.5	ns
t _{dis}	disable time	$\overline{\text{EN}}$ to Y; see Figure 8	[4]						
		V _{CC} = 0.8 V	-	20.3	-	-	-	-	ns
		V _{CC} = 1.1 V to 1.3 V	6.0	10.2	15.3	4.8	16.5	18.2	ns
		V _{CC} = 1.4 V to 1.6 V	4.4	7.8	11.2	3.1	12.3	13.6	ns
		V _{CC} = 1.65 V to 1.95 V	5.1	8.8	12.5	2.8	13.3	14.7	ns
		V _{CC} = 2.3 V to 2.7 V	3.6	6.3	8.6	2.6	9.5	10.5	ns
		V _{CC} = 3.0 V to 3.6 V	5.2	8.8	11.5	2.6	13.0	14.3	ns

Table 8. Dynamic characteristics ...continued

Voltages are referenced to GND (ground = 0 V); for test circuit see [Figure 9](#).

Symbol	Parameter	Conditions	25 °C			–40 °C to +125 °C			Unit
			Min	Typ ^[1]	Max	Min	Max (85 °C)	Max (125 °C)	
C_L = 5 pF, 10 pF, 15 pF and 30 pF									
C _{PD}	power dissipation capacitance	f _i = 1 MHz; \overline{EN} = GND; V _I = GND to V _{CC}		[5][6]					
		V _{CC} = 0.8 V	-	7.1	-	-	-	-	pF
		V _{CC} = 1.1 V to 1.3 V	-	12.9	-	-	-	-	pF
		V _{CC} = 1.4 V to 1.6 V	-	19.2	-	-	-	-	pF
		V _{CC} = 1.65 V to 1.95 V	-	19.9	-	-	-	-	pF
		V _{CC} = 2.3 V to 2.7 V	-	21.6	-	-	-	-	pF
		V _{CC} = 3.0 V to 3.6 V	-	24.3	-	-	-	-	pF

- [1] All typical values are measured at nominal V_{CC}.
- [2] t_{pd} is the same as t_{PLH} and t_{PHL}.
- [3] t_{en} is the same as t_{PZH} and t_{PZL}.
- [4] t_{dis} is the same as t_{PHZ} and t_{PLZ}.
- [5] C_{PD} is used to determine the dynamic power dissipation (P_D in μW).
 $P_D = C_{PD} \times V_{CC}^2 \times f_i \times N + \Sigma(C_L \times V_{CC}^2 \times f_o)$ where:
 f_i = input frequency in MHz;
 f_o = output frequency in MHz;
 C_L = output load capacitance in pF;
 V_{CC} = supply voltage in V;
 N = number of inputs switching;
 $\Sigma(C_L \times V_{CC}^2 \times f_o)$ = sum of the outputs.
- [6] Feedback current is included in C_{PD}.

12. Waveforms

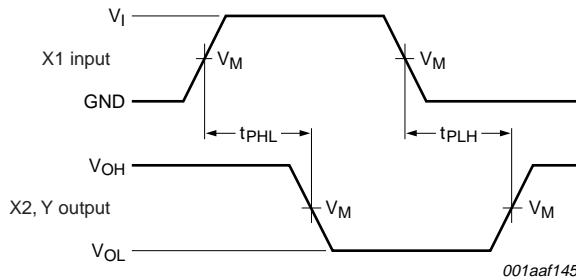

Measurement points are given in [Table 9](#).
 Logic levels: V_{OL} and V_{OH} are typical output voltage drop that occur with the output load.

Fig 7. The input (X1) to output (X2, Y) propagation delays

Table 9. Measurement points

Supply voltage	Output	Input		
V_{CC}	V_M	V_M	V_I	$t_r = t_f$
0.8 V to 3.6 V	$0.5 \times V_{CC}$	$0.5 \times V_{CC}$	V_{CC}	≤ 3.0 ns

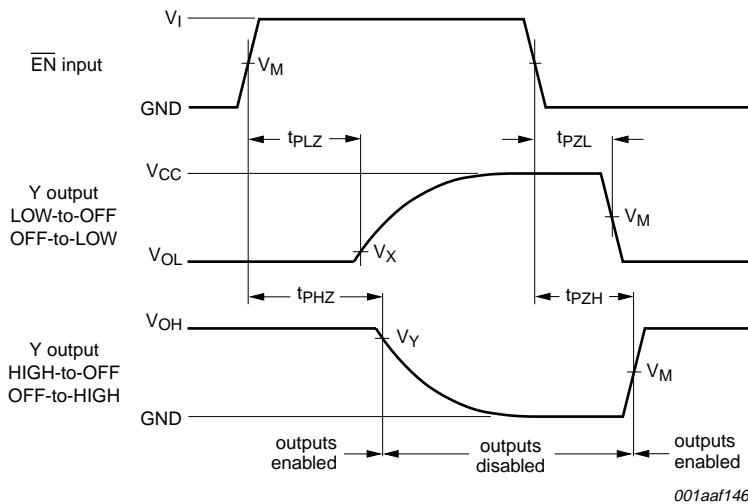

Measurement points are given in [Table 10](#).
 Logic levels: V_{OL} and V_{OH} are typical output voltage drop that occur with the output load.

Fig 8. Enable and disable times

Table 10. Measurement points

Supply voltage	Input	Output		
V_{CC}	V_M	V_M	V_X	V_Y
0.8 V to 1.6 V	$0.5 \times V_{CC}$	$0.5 \times V_{CC}$	$V_{OL} + 0.1$ V	$V_{OH} - 0.1$ V
1.65 V to 2.7 V	$0.5 \times V_{CC}$	$0.5 \times V_{CC}$	$V_{OL} + 0.15$ V	$V_{OH} - 0.15$ V
3.0 V to 3.6 V	$0.5 \times V_{CC}$	$0.5 \times V_{CC}$	$V_{OL} + 0.3$ V	$V_{OH} - 0.3$ V

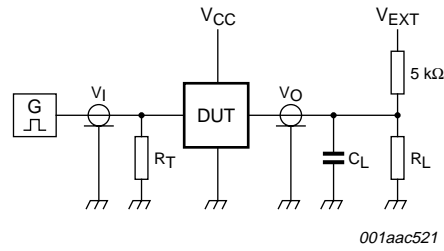

Test data is given in [Table 11](#).

Definitions for test circuit:

R_L = Load resistance.

C_L = Load capacitance including jig and probe capacitance.

R_T = Termination resistance should be equal to the output impedance Z_o of the pulse generator.

V_{EXT} = External voltage for measuring switching times.

Fig 9. Load circuitry for switching times

Table 11. Test data

Supply voltage	Load		V_{EXT}		
V_{CC}	C_L	R_L [1]	t_{PLH} , t_{PHL}	t_{PZH} , t_{PHZ}	t_{PZL} , t_{PLZ}
0.8 V to 3.6 V	5 pF, 10 pF, 15 pF and 30 pF	5 kΩ or 1 MΩ	open	GND	$2 \times V_{CC}$

[1] For measuring enable and disable times $R_L = 5 \text{ k}\Omega$, for measuring propagation delays, setup and hold times and pulse width $R_L = 1 \text{ M}\Omega$.

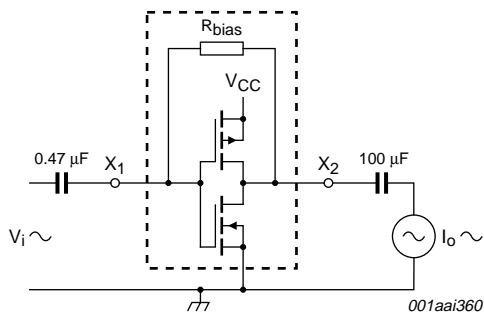

$$g_{fs} = \frac{\Delta I_O}{\Delta V_I}$$

$f_i = 1 \text{ kHz}$.

V_O is constant.

Fig 10. Test set-up for measuring forward transconductance

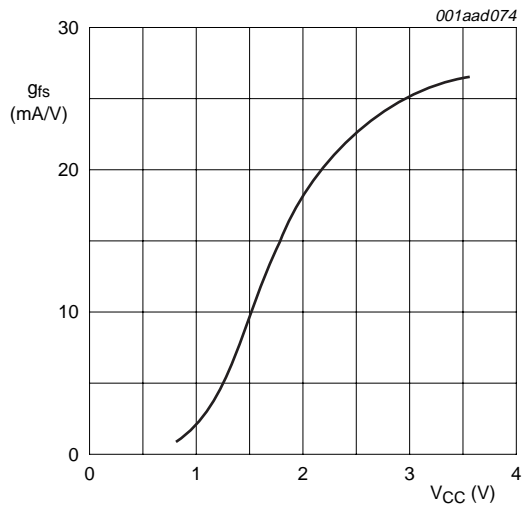

$T_{amb} = 25 \text{ }^\circ\text{C}$.

Fig 11. Typical forward transconductance as a function of supply voltage

13. Application information

Crystal controlled oscillator circuits are widely used in clock pulse generators because of their excellent frequency stability and wide operating frequency range. The use of the 74AUP1Z125 provides the additional advantages of low power dissipation, stable operation over a wide range of frequency and temperature and a very small footprint. This application information describes crystal characteristics, design and testing of crystal oscillator circuits based on the 74AUP1Z125.

13.1 Crystal characteristics

[Figure 12](#) is the equivalent circuit of a quartz crystal.

The reactive and resistive component of the impedance of the crystal alone and the crystal with a series and a parallel capacitance is shown in [Figure 13](#).

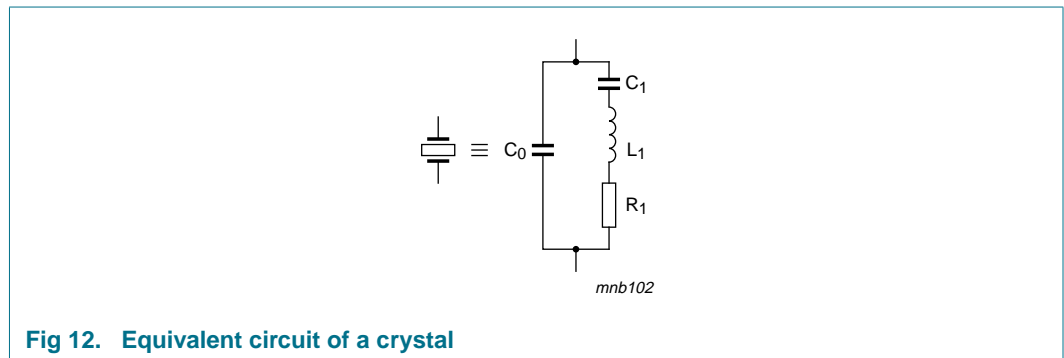
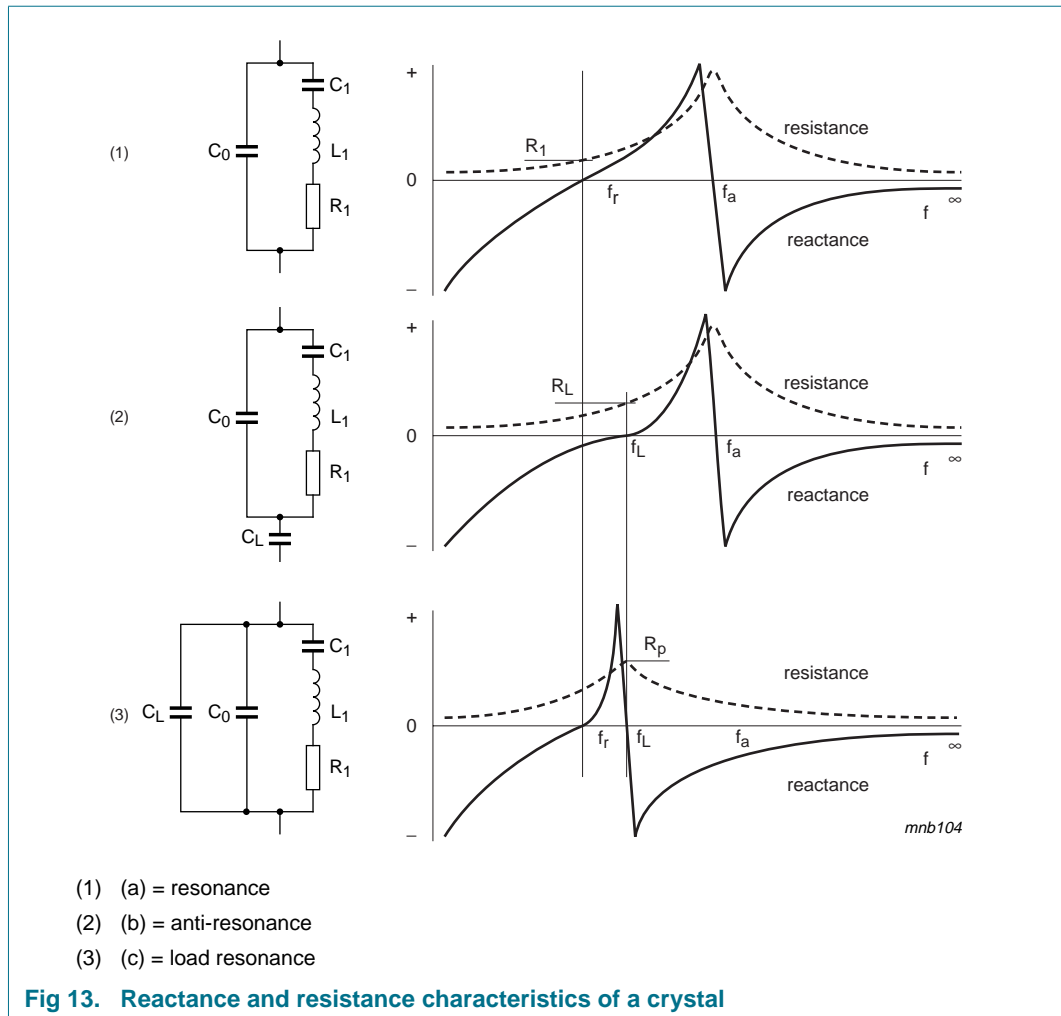

Fig 12. Equivalent circuit of a crystal



13.1.1 Design

Figure 14 shows the recommended way to connect a crystal to the 74AUP1Z125. This circuit is basically a Pierce oscillator circuit in which the crystal is operating at its fundamental frequency and is tuned by the parallel load capacitance of C₁ and C₂. C₁ and C₂ are in series with the crystal. They should be approximately equal. R₁ is the drive-limiting resistor and is set to approximately the same value as the reactance of C₁ at the crystal frequency (R₁ = X_{C1}). This will result in an input to the crystal of 50 % of the rail-to-rail output of X2. This keeps the drive level into the crystal within drive specifications (the designer should verify this). Overdriving the crystal can cause damage.

The internal bias resistor provides negative feedback and sets a bias point of the inverter near mid-supply, operating the 74AUP1GU04 in the high gain linear region.

To calculate the values of C₁ and C₂, the designer can use the formula:

$$C_L = \frac{C_1 \times C_2}{C_1 + C_2} + C_s$$

C_L is the load capacitance as specified by the crystal manufacturer, C_s is the stray capacitance of the circuit (for the 74AUP1Z125 this is equal to an input capacitance of 1.5 pF).

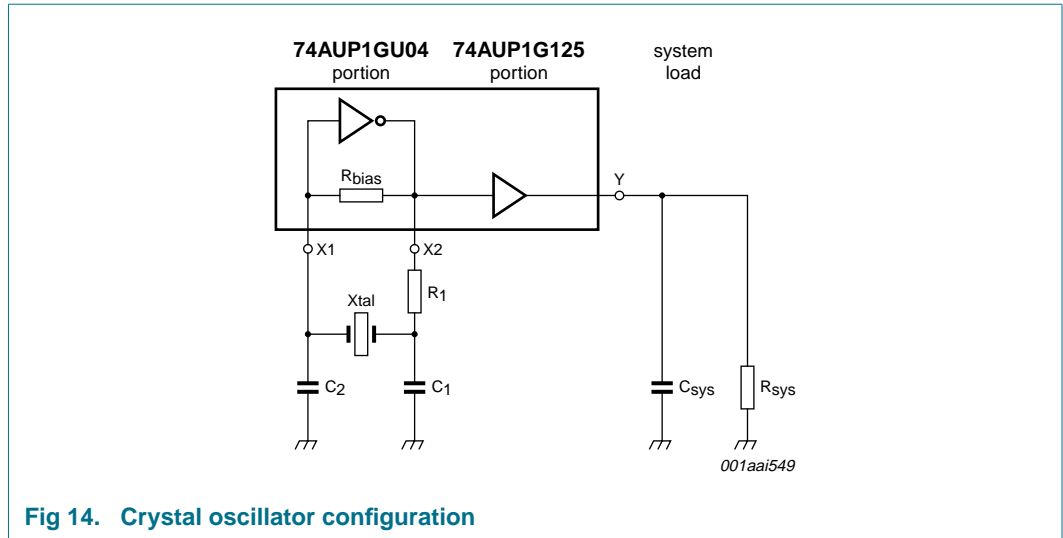

Fig 14. Crystal oscillator configuration

13.1.2 Testing

After the calculations are performed for a particular crystal, the oscillator circuit should be tested. The following simple checks will verify the prototype design of a crystal controlled oscillator circuit. Perform them after laying out the board:

- Test the oscillator over worst-case conditions (lowest supply voltage, worst-case crystal and highest operating temperature). Adding series and parallel resistors can simulate a worse case crystal.
- Insure that the circuit does not oscillate without the crystal.
- Check the frequency stability over a supply range greater than that which is likely to occur during normal operation.
- Check that the start-up time is within system requirements.

As the 74AUP1Z125 isolates the system loading, once the design is optimized, the single layout may work in multiple applications for any given crystal.

14. Package outline

Plastic surface-mounted package; 6 leads

SOT363

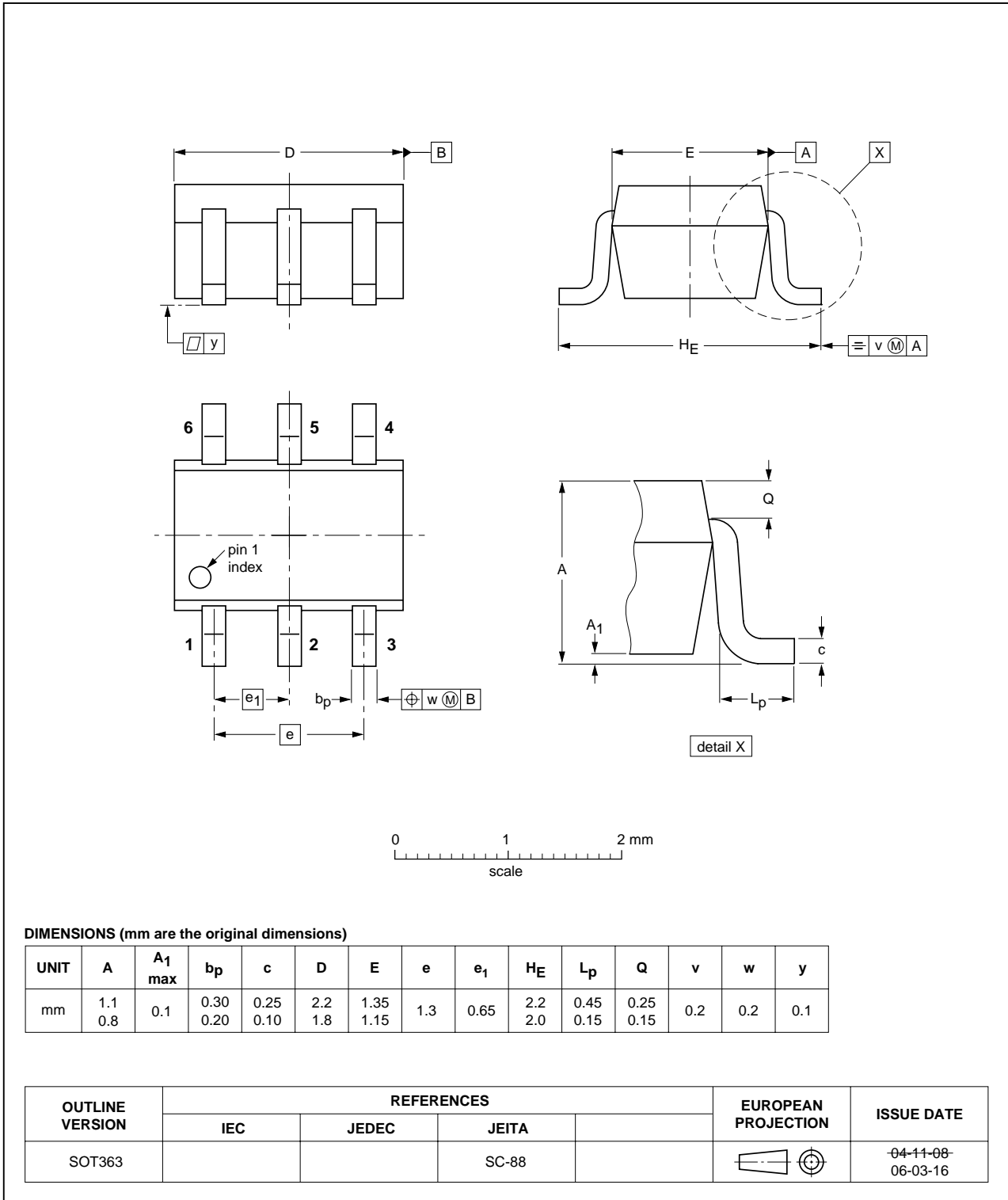

Fig 15. Package outline SOT363 (SC-88)

XSON6: plastic extremely thin small outline package; no leads; 6 terminals; body 1 x 1.45 x 0.5 mm

SOT886

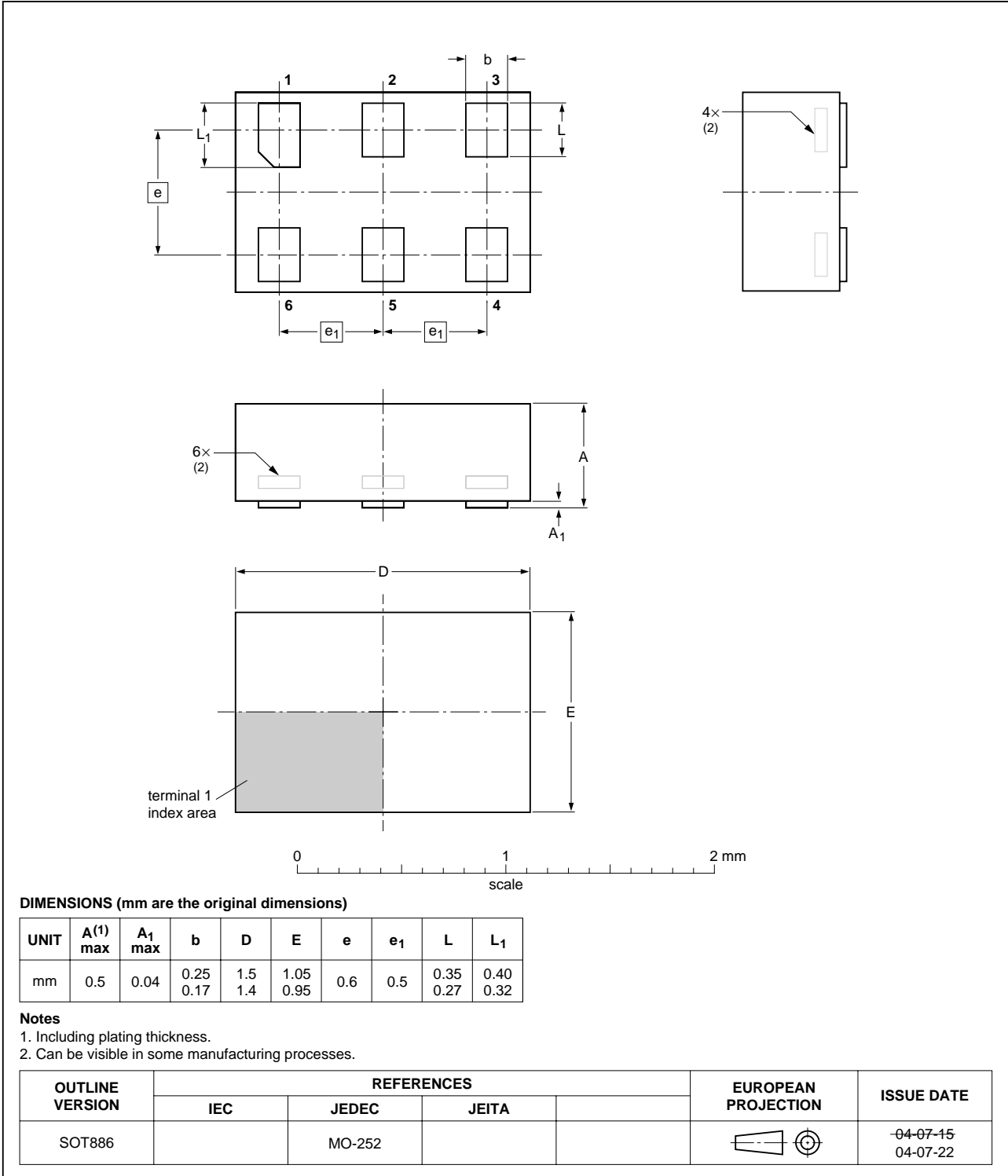

Fig 16. Package outline SOT886 (XSON6)

XSON6: plastic extremely thin small outline package; no leads; 6 terminals; body 1 x 1 x 0.5 mm

SOT891

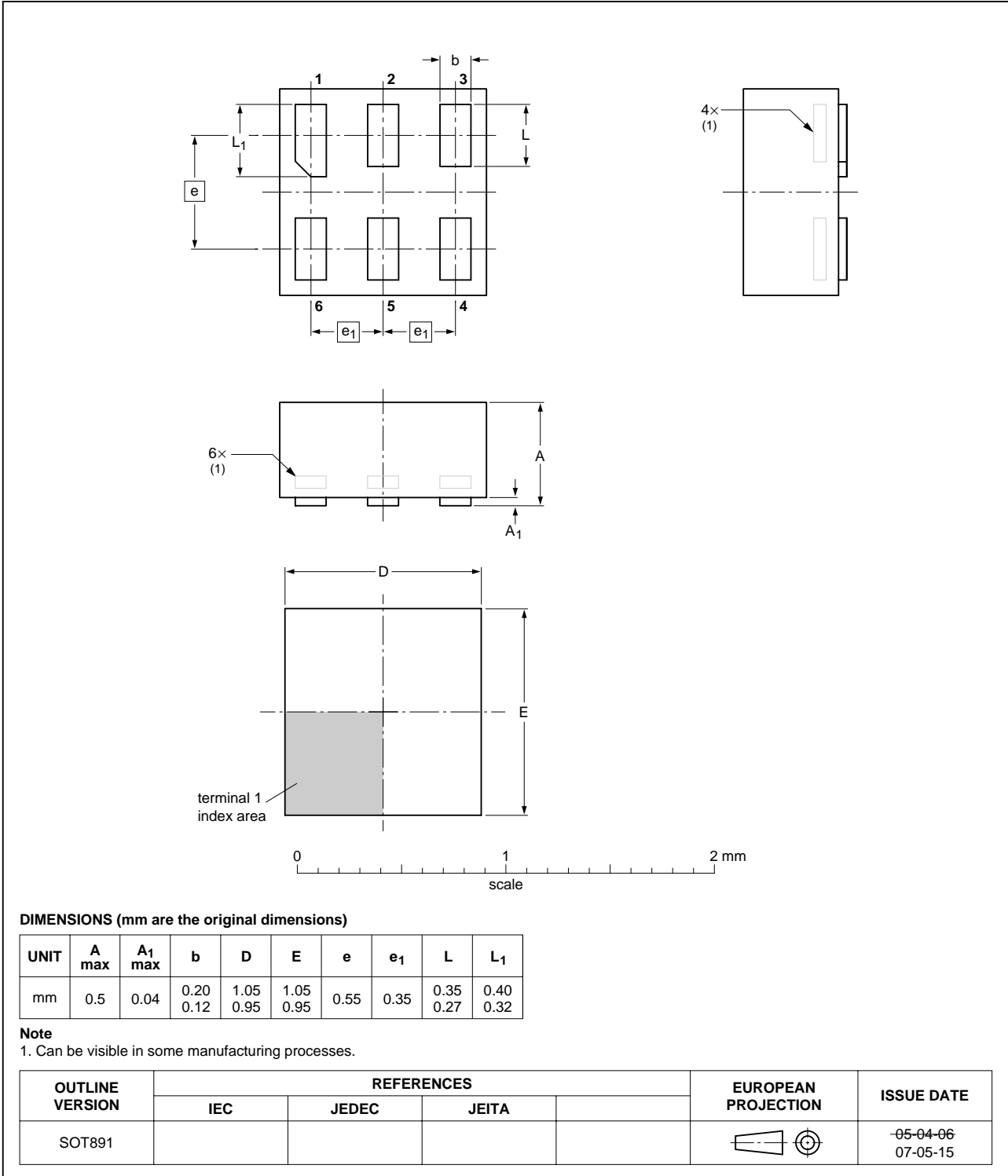

Fig 17. Package outline SOT891 (XSON6)

15. Abbreviations

Table 12. Abbreviations

Acronym	Description
CDM	Charged Device Model
CMOS	Complementary Metal-Oxide Semiconductor
DUT	Device Under Test
ESD	ElectroStatic Discharge
HBM	Human Body Model
MM	Machine Model

16. Revision history

Table 13. Revision history

Document ID	Release date	Data sheet status	Change notice	Supersedes
74AUP1Z125_2	20080807	Product data sheet	-	74AUP1Z125_1
Modifications:	<ul style="list-style-type: none"> The format of this data sheet has been redesigned to comply with the new identity guidelines of NXP Semiconductors. Legal texts have been adapted to the new company name where appropriate. Section 2 "Features": Removed: Low static power consumption; I_{CC} 0.9 μA maximum. Section 10 "Static characteristics": Removed: Feedback current (I_{fbck}). Changed: Maximum supply current (I_{CC}). Added: forward transconductance and bias resistance. Section 11 "Dynamic characteristics": Changed: Typical power dissipation capacitance. 			
74AUP1Z125_1	20060803	Product data sheet	-	-

17. Legal information

17.1 Data sheet status

Document status ^{[1][2]}	Product status ^[3]	Definition
Objective [short] data sheet	Development	This document contains data from the objective specification for product development.
Preliminary [short] data sheet	Qualification	This document contains data from the preliminary specification.
Product [short] data sheet	Production	This document contains the product specification.

[1] Please consult the most recently issued document before initiating or completing a design.

[2] The term 'short data sheet' is explained in section "Definitions".

[3] The product status of device(s) described in this document may have changed since this document was published and may differ in case of multiple devices. The latest product status information is available on the Internet at URL <http://www.nxp.com>.

17.2 Definitions

Draft — The document is a draft version only. The content is still under internal review and subject to formal approval, which may result in modifications or additions. NXP Semiconductors does not give any representations or warranties as to the accuracy or completeness of information included herein and shall have no liability for the consequences of use of such information.

Short data sheet — A short data sheet is an extract from a full data sheet with the same product type number(s) and title. A short data sheet is intended for quick reference only and should not be relied upon to contain detailed and full information. For detailed and full information see the relevant full data sheet, which is available on request via the local NXP Semiconductors sales office. In case of any inconsistency or conflict with the short data sheet, the full data sheet shall prevail.

17.3 Disclaimers

General — Information in this document is believed to be accurate and reliable. However, NXP Semiconductors does not give any representations or warranties, expressed or implied, as to the accuracy or completeness of such information and shall have no liability for the consequences of use of such information.

Right to make changes — NXP Semiconductors reserves the right to make changes to information published in this document, including without limitation specifications and product descriptions, at any time and without notice. This document supersedes and replaces all information supplied prior to the publication hereof.

Suitability for use — NXP Semiconductors products are not designed, authorized or warranted to be suitable for use in medical, military, aircraft, space or life support equipment, nor in applications where failure or

malfunction of an NXP Semiconductors product can reasonably be expected to result in personal injury, death or severe property or environmental damage. NXP Semiconductors accepts no liability for inclusion and/or use of NXP Semiconductors products in such equipment or applications and therefore such inclusion and/or use is at the customer's own risk.

Applications — Applications that are described herein for any of these products are for illustrative purposes only. NXP Semiconductors makes no representation or warranty that such applications will be suitable for the specified use without further testing or modification.

Limiting values — Stress above one or more limiting values (as defined in the Absolute Maximum Ratings System of IEC 60134) may cause permanent damage to the device. Limiting values are stress ratings only and operation of the device at these or any other conditions above those given in the Characteristics sections of this document is not implied. Exposure to limiting values for extended periods may affect device reliability.

Terms and conditions of sale — NXP Semiconductors products are sold subject to the general terms and conditions of commercial sale, as published at <http://www.nxp.com/profile/terms>, including those pertaining to warranty, intellectual property rights infringement and limitation of liability, unless explicitly otherwise agreed to in writing by NXP Semiconductors. In case of any inconsistency or conflict between information in this document and such terms and conditions, the latter will prevail.

No offer to sell or license — Nothing in this document may be interpreted or construed as an offer to sell products that is open for acceptance or the grant, conveyance or implication of any license under any copyrights, patents or other industrial or intellectual property rights.

17.4 Trademarks

Notice: All referenced brands, product names, service names and trademarks are the property of their respective owners.

18. Contact information

For more information, please visit: <http://www.nxp.com>

For sales office addresses, please send an email to: salesaddresses@nxp.com

19. Contents

1 General description 1

2 Features 1

3 Ordering information 2

4 Marking 2

5 Functional diagram 2

6 Pinning information 3

6.1 Pinning 3

6.2 Pin description 3

7 Functional description 3

8 Limiting values 4

9 Recommended operating conditions 4

10 Static characteristics 5

11 Dynamic characteristics 14

12 Waveforms 19

13 Application information 21

13.1 Crystal characteristics 21

13.1.1 Design 22

13.1.2 Testing 23

14 Package outline 24

15 Abbreviations 27

16 Revision history 27

17 Legal information 28

17.1 Data sheet status 28

17.2 Definitions 28

17.3 Disclaimers 28

17.4 Trademarks 28

18 Contact information 28

19 Contents 29

Please be aware that important notices concerning this document and the product(s) described herein, have been included in section 'Legal information'.



© NXP B.V. 2008.

All rights reserved.

For more information, please visit: <http://www.nxp.com>

For sales office addresses, please send an email to: salesaddresses@nxp.com

Date of release: 7 August 2008

Document identifier: 74AUP1Z125_2