

74AUP1T45

Low-power dual supply translating transceiver; 3-state

Rev. 02 — 3 August 2009

Product data sheet

1. General description

The 74AUP1T45 is a single bit transceiver featuring two data input-outputs (A and B), a direction control input (DIR) and dual supply pins ($V_{CC(A)}$ and $V_{CC(B)}$) which enable bidirectional level translation. Both $V_{CC(A)}$ and $V_{CC(B)}$ can be supplied at any voltage between 1.1 V and 3.6 V making the device suitable for interfacing between any of the low voltage nodes (1.2 V, 1.5 V, 1.8 V, 2.5 V and 3.3 V). Pins A and DIR are referenced to $V_{CC(A)}$ and pin B is referenced to $V_{CC(B)}$. A HIGH on DIR allows transmission from A to B and a LOW on DIR allows transmission from B to A.

Schmitt trigger action on all inputs makes the circuit tolerant of slower input rise and fall times across the entire $V_{CC(A)}$ and $V_{CC(B)}$ ranges. The device ensures low static and dynamic power consumption and is fully specified for partial power-down applications using I_{OFF} . The I_{OFF} circuitry disables the output, preventing any damaging backflow current through the device when it is powered down. In suspend mode when either $V_{CC(A)}$ or $V_{CC(B)}$ are at GND, both A and B are in the high-impedance OFF-state.

2. Features

- Wide supply voltage range:
 - ◆ $V_{CC(A)}$: 1.1 V to 3.6 V
 - ◆ $V_{CC(B)}$: 1.1 V to 3.6 V
- High noise immunity
- Complies with JEDEC standards:
 - ◆ JESD8-7 (1.2 V to 1.95 V)
 - ◆ JESD8-5 (1.8 V to 2.7 V)
 - ◆ JESD8-B (2.7 V to 3.6 V)
- ESD protection:
 - ◆ HBM JESD22-A114E Class 3A exceeds 5000 V
 - ◆ MM JESD22-A115-A exceeds 200 V
 - ◆ CDM JESD22-C101C exceeds 1000 V
- Low static power consumption; $I_{CC} = 0.9 \mu\text{A}$ (maximum)
- Suspend mode
- Latch-up performance exceeds 100 mA per JESD 78 Class II
- Inputs accept voltages up to 3.6 V
- Low noise overshoot and undershoot < 10 % of V_{CC}
- I_{OFF} circuitry provides partial Power-down mode operation
- Multiple package options
- Specified from $-40 \text{ }^\circ\text{C}$ to $+85 \text{ }^\circ\text{C}$ and $-40 \text{ }^\circ\text{C}$ to $+125 \text{ }^\circ\text{C}$

3. Ordering information

Table 1. Ordering information

Type number	Package			Version
	Temperature range	Name	Description	
74AUP1T45GW	-40 °C to +125 °C	SC-88	plastic surface-mounted package; 6 leads	SOT363
74AUP1T45GM	-40 °C to +125 °C	XSON6	plastic extremely thin small outline package; no leads; 6 terminals; body 1 × 1.45 × 0.5 mm	SOT886
74AUP1T45GF	-40 °C to +125 °C	XSON6	plastic extremely thin small outline package; no leads; 6 terminals; body 1 × 1 × 0.5 mm	SOT891

4. Marking

Table 2. Marking

Type number	Marking code ^[1]
74AUP1T45GW	p5
74AUP1T45GM	p5
74AUP1T45GF	p5

[1] The pin 1 indicator is located on the lower left corner of the device, below the marking code.

5. Functional diagram

Fig 1. Logic symbol

Fig 2. Logic diagram

6. Pinning information

6.1 Pinning

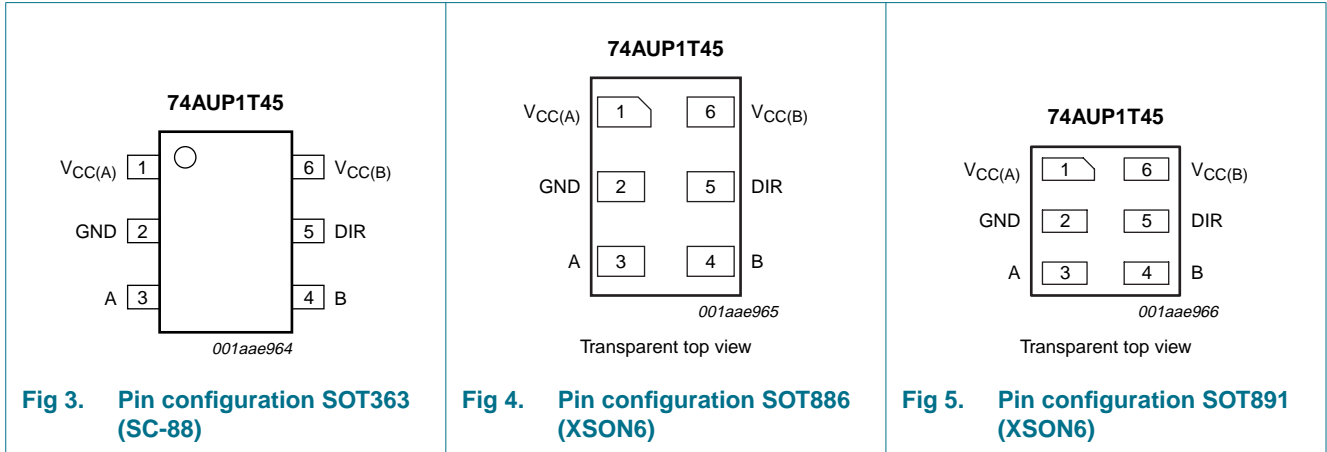

6.2 Pin description

Table 3. Pin description

Symbol	Pin	Description
V _{CC(A)}	1	supply voltage port A
GND	2	ground (0 V)
A	3	data input or output A
B	4	data input or output B
DIR	5	direction control DIR
V _{CC(B)}	6	supply voltage port B

7. Functional description

Table 4. Function table^[1]

Supply voltage	Input ^[2]	Input/output ^[3]	
	DIR	A	B
1.1 V to 3.6 V	L	A = B	input
1.1 V to 3.6 V	H	input	B = A
GND	X	suspend mode	suspend mode

[1] H = HIGH voltage level; L = LOW voltage level; X = don't care.

[2] The DIR input circuit is referenced to V_{CC(A)}.

[3] The input circuit of the data I/Os are always active.

8. Limiting values

Table 5. Limiting values

In accordance with the Absolute Maximum Rating System (IEC 60134). Voltages are referenced to GND (ground = 0 V).

Symbol	Parameter	Conditions	Min	Max	Unit
$V_{CC(A)}$	supply voltage port A		-0.5	+4.6	V
$V_{CC(B)}$	supply voltage port B		-0.5	+4.6	V
I_{IK}	input clamping current	$V_I < 0$ V	-50	-	mA
V_I	input voltage		[1] -0.5	+4.6	V
I_{OK}	output clamping current	$V_O < 0$ V	-50	-	mA
V_O	output voltage	Active mode			
		A port	[1][2] -0.5	$V_{CC(A)} + 0.5$	V
		B port	[1][2] -0.5	$V_{CC(B)} + 0.5$	V
		suspend or 3-state mode	[1][2] -0.5	+4.6	V
I_O	output current	$V_O = 0$ V to V_{CC}	-	± 20	mA
I_{CC}	supply current		-	50	mA
I_{GND}	ground current		-50	-	mA
T_{stg}	storage temperature		-65	+150	°C
P_{tot}	total power dissipation	$T_{amb} = -40$ °C to +125 °C	[3] -	250	mW

[1] The minimum input and output voltage ratings may be exceeded if the input and output current ratings are observed.

[2] The values of $V_{CC(A)}$ and $V_{CC(B)}$ are provided in the recommended operating conditions; see [Table 6](#).

[3] For SC-88 packages: above 87.5 °C the value of P_{tot} derates linearly with 4.0 mW/K.
For XSON6 packages: above 118 °C the value of P_{tot} derates linearly with 7.8 mW/K.

9. Recommended operating conditions

Table 6. Recommended operating conditions

Symbol	Parameter	Conditions	Min	Max	Unit
$V_{CC(A)}$	supply voltage port A		1.1	3.6	V
$V_{CC(B)}$	supply voltage port B		1.1	3.6	V
V_I	input voltage		0	3.6	V
V_O	output voltage		[1] 0	V_{CCO}	V
T_{amb}	ambient temperature		-40	+125	°C
$\Delta t/\Delta V$	input transition rise and fall rate	$V_{CCI} = 1.1$ V to 3.6 V	0	200	ns/V

[1] V_{CCO} is the supply voltage associated with the output port.

10. Static characteristics

Table 7. Static characteristics

At recommended operating conditions; voltages are referenced to GND (ground = 0 V).

Symbol	Parameter	Conditions	Min	Typ	Max	Unit	
T_{amb} = 25 °C							
V _{IH}	HIGH-level input voltage	data input	[1][3]				
		V _{CCI} = 1.1 V to 1.95 V	0.65 × V _{CCI}	-	-	V	
		V _{CCI} = 2.3 V to 2.7 V	1.6	-	-	V	
		V _{CCI} = 3.0 V to 3.6 V	2.0	-	-	V	
		DIR input	[1][4]				
		V _{CCI} = 1.1 V to 1.95 V	0.65 × V _{CC(A)}	-	-	V	
		V _{CCI} = 2.3 V to 2.7 V	1.6	-	-	V	
		V _{CCI} = 3.0 V to 3.6 V	2.0	-	-	V	
		V _{IL}	LOW-level input voltage	data input	[1][3]		
V _{CCI} = 1.1 V to 1.95 V	-			-	0.35 × V _{CCI}	V	
V _{CCI} = 2.3 V to 2.7 V	-			-	0.7	V	
V _{CCI} = 3.0 V to 3.6 V	-			-	0.9	V	
DIR input	[1][4]						
V _{CCI} = 1.1 V to 1.95 V	-			-	0.35 × V _{CC(A)}	V	
V _{CCI} = 2.3 V to 2.7 V	-			-	0.7	V	
V _{CCI} = 3.0 V to 3.6 V	-			-	0.9	V	
V _{OH}	HIGH-level output voltage			V _I = V _{IH}			
		I _O = -20 μA; V _{CC(A)} = V _{CC(B)} = 1.1 V to 3.6 V	[2]	V _{CCO} - 0.1	-	-	V
		I _O = -1.1 mA; V _{CC(A)} = V _{CC(B)} = 1.1 V	[2]	0.75 × V _{CCO}	-	-	V
		I _O = -1.7 mA; V _{CC(A)} = V _{CC(B)} = 1.4 V		1.11	-	-	V
		I _O = -1.9 mA; V _{CC(A)} = V _{CC(B)} = 1.65 V		1.32	-	-	V
		I _O = -2.3 mA; V _{CC(A)} = V _{CC(B)} = 2.3 V		2.05	-	-	V
		I _O = -3.1 mA; V _{CC(A)} = V _{CC(B)} = 2.3 V		1.9	-	-	V
		I _O = -2.7 mA; V _{CC(A)} = V _{CC(B)} = 3.0 V		2.72	-	-	V
		I _O = -4.0 mA; V _{CC(A)} = V _{CC(B)} = 3.0 V		2.6	-	-	V
V _{OL}	LOW-level output voltage	V _I = V _{IL}					
		I _O = 20 μA; V _{CC(A)} = V _{CC(B)} = 1.1 V to 3.6 V		-	-	0.1	V
		I _O = 1.1 mA; V _{CC(A)} = V _{CC(B)} = 1.1 V	[2]	-	-	0.3 × V _{CCO}	V
		I _O = 1.7 mA; V _{CC(A)} = V _{CC(B)} = 1.4 V		-	-	0.31	V
		I _O = 1.9 mA; V _{CC(A)} = V _{CC(B)} = 1.65 V		-	-	0.31	V
		I _O = 2.3 mA; V _{CC(A)} = V _{CC(B)} = 2.3 V		-	-	0.31	V
		I _O = 3.1 mA; V _{CC(A)} = V _{CC(B)} = 2.3 V		-	-	0.44	V
		I _O = 2.7 mA; V _{CC(A)} = V _{CC(B)} = 3.0 V		-	-	0.31	V
		I _O = 4.0 mA; V _{CC(A)} = V _{CC(B)} = 3.0 V		-	-	0.44	V
I _I	input leakage current	DIR input; V _I = GND to V _{CC(A)} ; V _{CC(A)} = V _{CC(B)} = 1.1 V to 3.6 V	-	-	±0.1	μA	

Table 7. Static characteristics ...continued

At recommended operating conditions; voltages are referenced to GND (ground = 0 V).

Symbol	Parameter	Conditions	Min	Typ	Max	Unit
I_{OZ}	OFF-state output current	A or B port; $V_I = V_{IH}$ or V_{IL} ; $V_O = 0$ V to V_{CCO} ; $V_{CC(A)} = V_{CC(B)} = 1.1$ V to 3.6 V	[2] -	-	± 0.1	μ A
I_{OFF}	power-off leakage current	A port; V_I or $V_O = 0$ V to 3.6 V; $V_{CC(A)} = 0$ V; $V_{CC(B)} = 1.1$ V to 3.6 V	-	-	± 0.2	μ A
		B port; V_I or $V_O = 0$ V to 3.6 V; $V_{CC(B)} = 0$ V; $V_{CC(A)} = 1.1$ V to 3.6 V	-	-	± 0.2	μ A
		DIR input; V_I or $V_O = 0$ V to 3.6 V; $V_{CC(A)} = 0$ V; $V_{CC(B)} = 1.1$ V to 3.6 V	-	-	± 0.2	μ A
ΔI_{OFF}	additional power-off leakage current	A port; V_I or $V_O = 0$ V to 3.6 V; $V_{CC(A)} = 0$ V to 0.2 V; $V_{CC(B)} = 1.1$ V to 3.6 V	-	-	± 0.2	μ A
		B port; V_I or $V_O = 0$ V to 3.6 V; $V_{CC(B)} = 0$ V to 0.2 V; $V_{CC(A)} = 1.1$ V to 3.6 V	-	-	± 0.2	μ A
		DIR input; V_I or $V_O = 0$ V to 3.6 V; $V_{CC(A)} = 0$ V to 0.2 V; $V_{CC(B)} = 1.1$ V to 3.6 V	-	-	± 0.2	μ A
I_{CC}	supply current	A port; $V_I = \text{GND}$ or V_{CCI} ; $I_O = 0$ A	[1]	-	-	-
		$V_{CC(A)} = V_{CC(B)} = 1.1$ V to 3.6 V	-	-	0.5	μ A
		$V_{CC(A)} = 3.6$ V; $V_{CC(B)} = 0$ V	-	-	0.5	μ A
		$V_{CC(A)} = 0$ V; $V_{CC(B)} = 3.6$ V	-	0	-	μ A
		B port; $V_I = \text{GND}$ or V_{CCI} ; $I_O = 0$ A	[1]	-	-	-
		$V_{CC(A)} = V_{CC(B)} = 1.1$ V to 3.6 V	-	-	0.5	μ A
		$V_{CC(A)} = 3.6$ V; $V_{CC(B)} = 0$ V	-	0	-	μ A
		$V_{CC(A)} = 0$ V; $V_{CC(B)} = 3.6$ V	-	-	0.5	μ A
A plus B port ($I_{CC(A)} + I_{CC(B)}$); $I_O = 0$ A; $V_I = \text{GND}$ or V_{CCI} ; $V_{CC(A)} = V_{CC(B)} = 1.1$ V to 3.6 V	[1]	-	-	0.5	μ A	
ΔI_{CC}	additional supply current	A port; $V_{CC(A)} = V_{CC(B)} = 3.3$ V; A port at $V_{CC(A)} - 0.6$ V; DIR at $V_{CC(A)}$; B port = open	-	-	40	μ A
		B port; $V_{CC(A)} = V_{CC(B)} = 3.3$ V; B port at $V_{CC(B)} - 0.6$ V; DIR at GND; A port = open	-	-	40	μ A
		DIR input; $V_{CC(A)} = V_{CC(B)} = 3.3$ V; A port at $V_{CC(A)}$ or GND; B port = open; DIR at $V_{CC(A)} - 0.6$ V	-	-	40	μ A
C_I	input capacitance	DIR input; $V_I = \text{GND}$ or $V_{CC(A)}$; $V_{CC(A)} = V_{CC(B)} = 1.1$ V to 3.6 V	-	0.9	-	pF
$C_{I/O}$	input/output capacitance	A and B port; suspend mode; $V_{CCI} = 0$ V; $V_{CCO} = 1.1$ V to 3.6 V; $V_O = V_{CCO}$ or GND	[1][2]	-	2.0	pF

Table 7. Static characteristics ...continued

At recommended operating conditions; voltages are referenced to GND (ground = 0 V).

Symbol	Parameter	Conditions	Min	Typ	Max	Unit
T_{amb} = -40 °C to +85 °C						
V _{IH}	HIGH-level input voltage	data input	[1][3]			
		V _{CCI} = 1.1 V to 1.95 V	0.65 × V _{CCI}	-	-	V
		V _{CCI} = 2.3 V to 2.7 V	1.6	-	-	V
		V _{CCI} = 3.0 V to 3.6 V	2.0	-	-	V
		DIR input	[1][4]			
		V _{CCI} = 1.1 V to 1.95 V	0.65 × V _{CC(A)}	-	-	V
V _{IL}	LOW-level input voltage	data input	[1][3]			
		V _{CCI} = 1.1 V to 1.95 V	-	-	0.35 × V _{CCI}	V
		V _{CCI} = 2.3 V to 2.7 V	-	-	0.7	V
		V _{CCI} = 3.0 V to 3.6 V	-	-	0.9	V
		DIR input	[1][4]			
		V _{CCI} = 1.1 V to 1.95 V	-	-	0.35 × V _{CC(A)}	V
V _{OH}	HIGH-level output voltage	V _I = V _{IH}				
		I _O = -20 μA; V _{CC(A)} = V _{CC(B)} = 1.1 V to 3.6 V	[2] V _{CCO} - 0.1	-	-	V
		I _O = -1.1 mA; V _{CC(A)} = V _{CC(B)} = 1.1 V	[2] 0.7 × V _{CCO}	-	-	V
		I _O = -1.7 mA; V _{CC(A)} = V _{CC(B)} = 1.4 V	1.03	-	-	V
		I _O = -1.9 mA; V _{CC(A)} = V _{CC(B)} = 1.65 V	1.30	-	-	V
		I _O = -2.3 mA; V _{CC(A)} = V _{CC(B)} = 2.3 V	1.97	-	-	V
		I _O = -3.1 mA; V _{CC(A)} = V _{CC(B)} = 2.3 V	1.85	-	-	V
		I _O = -2.7 mA; V _{CC(A)} = V _{CC(B)} = 3.0 V	2.67	-	-	V
V _{OL}	LOW-level output voltage	V _I = V _{IL}				
		I _O = 20 μA; V _{CC(A)} = V _{CC(B)} = 1.1 V to 3.6 V	-	-	0.1	V
		I _O = 1.1 mA; V _{CC(A)} = V _{CC(B)} = 1.1 V	[2] -	-	0.3 × V _{CCO}	V
		I _O = 1.7 mA; V _{CC(A)} = V _{CC(B)} = 1.4 V	-	-	0.37	V
		I _O = 1.9 mA; V _{CC(A)} = V _{CC(B)} = 1.65 V	-	-	0.35	V
		I _O = 2.3 mA; V _{CC(A)} = V _{CC(B)} = 2.3 V	-	-	0.33	V
		I _O = 3.1 mA; V _{CC(A)} = V _{CC(B)} = 2.3 V	-	-	0.45	V
		I _O = 2.7 mA; V _{CC(A)} = V _{CC(B)} = 3.0 V	-	-	0.33	V
I _I	input leakage current	DIR input; V _I = GND to V _{CC(A)} ; V _{CC(A)} = V _{CC(B)} = 1.1 V to 3.6 V	-	-	±0.5	μA
		A or B port; V _I = V _{IH} or V _{IL} ; V _O = 0 V to V _{CCO} ; V _{CC(A)} = V _{CC(B)} = 1.1 V to 3.6 V	[2] -	-	±0.5	μA

Table 7. Static characteristics ...continued

At recommended operating conditions; voltages are referenced to GND (ground = 0 V).

Symbol	Parameter	Conditions	Min	Typ	Max	Unit
I _{OFF}	power-off leakage current	A port; V _I or V _O = 0 V to 3.6 V; V _{CC(A)} = 0 V; V _{CC(B)} = 1.1 V to 3.6 V	-	-	±0.5	μA
		B port; V _I or V _O = 0 V to 3.6 V; V _{CC(B)} = 0 V; V _{CC(A)} = 1.1 V to 3.6 V	-	-	±0.5	μA
		DIR input; V _I or V _O = 0 V to 3.6 V; V _{CC(A)} = 0 V; V _{CC(B)} = 1.1 V to 3.6 V	-	-	±0.5	μA
ΔI _{OFF}	additional power-off leakage current	A port; V _I or V _O = 0 V to 3.6 V; V _{CC(A)} = 0 V to 0.2 V; V _{CC(B)} = 1.1 V to 3.6 V	-	-	±0.6	μA
		B port; V _I or V _O = 0 V to 3.6 V; V _{CC(B)} = 0 V to 0.2 V; V _{CC(A)} = 1.1 V to 3.6 V	-	-	±0.6	μA
		DIR input; V _I or V _O = 0 V to 3.6 V; V _{CC(A)} = 0 V to 0.2 V; V _{CC(B)} = 1.1 V to 3.6 V	-	-	±0.6	μA
I _{CC}	supply current	A port; V _I = GND or V _{CCI} ; I _O = 0 A	[1]	-	-	-
		V _{CC(A)} = V _{CC(B)} = 1.1 V to 3.6 V	-	-	0.9	μA
		V _{CC(A)} = 3.6 V; V _{CC(B)} = 0 V	-	-	0.9	μA
		V _{CC(A)} = 0 V; V _{CC(B)} = 3.6 V	-	0	-	μA
		B port; V _I = GND or V _{CCI} ; I _O = 0 A	[1]	-	-	-
		V _{CC(A)} = V _{CC(B)} = 1.1 V to 3.6 V	-	-	0.9	μA
		V _{CC(A)} = 3.6 V; V _{CC(B)} = 0 V	-	0	-	μA
ΔI _{CC}	additional supply current	A plus B port (I _{CC(A)} + I _{CC(B)}); I _O = 0 A; V _I = GND or V _{CCI} ; V _{CC(A)} = V _{CC(B)} = 1.1 V to 3.6 V	[1]	-	0.9	μA
		A port; V _{CC(A)} = V _{CC(B)} = 3.3 V; A port at V _{CC(A)} - 0.6 V; DIR at V _{CC(A)} ; B port = open	-	-	50	μA
		B port; V _{CC(A)} = V _{CC(B)} = 3.3 V; B port at V _{CC(B)} - 0.6 V; DIR at GND; A port = open	-	-	50	μA
		DIR input; V _{CC(A)} = V _{CC(B)} = 3.3 V; A port at V _{CC(A)} or GND; B port = open; DIR at V _{CC(A)} - 0.6 V	-	-	50	μA
T_{amb} = -40 °C to +125 °C						
V _{IH}	HIGH-level input voltage	data input	[1][3]	-	-	-
		V _{CCI} = 1.1 V to 1.95 V	0.7 × V _{CCI}	-	-	V
		V _{CCI} = 2.3 V to 2.7 V	1.6	-	-	V
		V _{CCI} = 3.0 V to 3.6 V	2.0	-	-	V
		DIR input	[1][4]	-	-	-
		V _{CCI} = 1.1 V to 1.95 V	0.7 × V _{CC(A)}	-	-	V
		V _{CCI} = 2.3 V to 2.7 V	1.6	-	-	V
V _{CCI} = 3.0 V to 3.6 V	2.0	-	-	V		

Table 7. Static characteristics ...continued

At recommended operating conditions; voltages are referenced to GND (ground = 0 V).

Symbol	Parameter	Conditions	Min	Typ	Max	Unit	
V _{IL}	LOW-level input voltage	data input	[1][3]				
		V _{CCI} = 1.1 V to 1.95 V	-	-	0.3 × V _{CCI}	V	
		V _{CCI} = 2.3 V to 2.7 V	-	-	0.7	V	
		V _{CCI} = 3.0 V to 3.6 V	-	-	0.9	V	
		DIR input	[1][4]				
		V _{CCI} = 1.1 V to 1.95 V	-	-	0.3 × V _{CC(A)}	V	
		V _{CCI} = 2.3 V to 2.7 V	-	-	0.7	V	
V _{OH}	HIGH-level output voltage	V _I = V _{IH}					
		I _O = -20 μA; V _{CC(A)} = V _{CC(B)} = 1.1 V to 3.6 V	[2]	V _{CCO} - 0.11	-	-	V
		I _O = -1.1 mA; V _{CC(A)} = V _{CC(B)} = 1.1 V	[2]	0.6 × V _{CCO}	-	-	V
		I _O = -1.7 mA; V _{CC(A)} = V _{CC(B)} = 1.4 V		0.93	-	-	V
		I _O = -1.9 mA; V _{CC(A)} = V _{CC(B)} = 1.65 V		1.17	-	-	V
		I _O = -2.3 mA; V _{CC(A)} = V _{CC(B)} = 2.3 V		1.77	-	-	V
		I _O = -3.1 mA; V _{CC(A)} = V _{CC(B)} = 2.3 V		1.67	-	-	V
		I _O = -2.7 mA; V _{CC(A)} = V _{CC(B)} = 3.0 V		2.40	-	-	V
V _{OL}	LOW-level output voltage	V _I = V _{IL}					
		I _O = 20 μA; V _{CC(A)} = V _{CC(B)} = 1.1 V to 3.6 V		-	-	0.11	V
		I _O = 1.1 mA; V _{CC(A)} = V _{CC(B)} = 1.1 V	[2]	-	-	0.33 × V _{CCO}	V
		I _O = 1.7 mA; V _{CC(A)} = V _{CC(B)} = 1.4 V		-	-	0.41	V
		I _O = 1.9 mA; V _{CC(A)} = V _{CC(B)} = 1.65 V		-	-	0.39	V
		I _O = 2.3 mA; V _{CC(A)} = V _{CC(B)} = 2.3 V		-	-	0.36	V
		I _O = 3.1 mA; V _{CC(A)} = V _{CC(B)} = 2.3 V		-	-	0.50	V
		I _O = 2.7 mA; V _{CC(A)} = V _{CC(B)} = 3.0 V		-	-	0.36	V
I _I	input leakage current	DIR input; V _I = GND to V _{CC(A)} ; V _{CC(A)} = V _{CC(B)} = 1.1 V to 3.6 V		-	-	±0.75	μA
I _{OZ}	OFF-state output current	A or B port; V _I = V _{IH} or V _{IL} ; V _O = 0 V to V _{CCO} ; V _{CC(A)} = V _{CC(B)} = 1.1 V to 3.6 V	[2]	-	-	±0.75	μA
I _{OFF}	power-off leakage current	A port; V _I or V _O = 0 V to 3.6 V; V _{CC(A)} = 0 V; V _{CC(B)} = 1.1 V to 3.6 V		-	-	±0.75	μA
		B port; V _I or V _O = 0 V to 3.6 V; V _{CC(B)} = 0 V; V _{CC(A)} = 1.1 V to 3.6 V		-	-	±0.75	μA
		DIR input; V _I or V _O = 0 V to 3.6 V; V _{CC(A)} = 0 V; V _{CC(B)} = 1.1 V to 3.6 V		-	-	±0.75	μA

Table 7. Static characteristics ...continued

At recommended operating conditions; voltages are referenced to GND (ground = 0 V).

Symbol	Parameter	Conditions	Min	Typ	Max	Unit
ΔI_{OFF}	additional power-off leakage current	A port; V_I or $V_O = 0$ V to 3.6 V; $V_{CC(A)} = 0$ V to 0.2 V; $V_{CC(B)} = 1.1$ V to 3.6 V	-	-	± 0.75	μ A
		B port; V_I or $V_O = 0$ V to 3.6 V; $V_{CC(B)} = 0$ V to 0.2 V; $V_{CC(A)} = 1.1$ V to 3.6 V	-	-	± 0.75	μ A
		DIR input; V_I or $V_O = 0$ V to 3.6 V; $V_{CC(A)} = 0$ V to 0.2 V; $V_{CC(B)} = 1.1$ V to 3.6 V	-	-	± 0.75	μ A
I_{CC}	supply current	A port; $V_I = GND$ or V_{CCI} ; $I_O = 0$ A	[1]	-	-	-
		$V_{CC(A)} = V_{CC(B)} = 1.1$ V to 3.6 V	-	-	1.4	μ A
		$V_{CC(A)} = 3.6$ V; $V_{CC(B)} = 0$ V	-	-	1.4	μ A
		$V_{CC(A)} = 0$ V; $V_{CC(B)} = 3.6$ V	-	0	-	μ A
		B port; $V_I = GND$ or V_{CCI} ; $I_O = 0$ A	[1]	-	-	-
		$V_{CC(A)} = V_{CC(B)} = 1.1$ V to 3.6 V	-	-	1.4	μ A
		$V_{CC(A)} = 3.6$ V; $V_{CC(B)} = 0$ V	-	0	-	μ A
		$V_{CC(A)} = 0$ V; $V_{CC(B)} = 3.6$ V	-	-	1.4	μ A
		A plus B port ($I_{CC(A)} + I_{CC(B)}$); $I_O = 0$ A; $V_I = GND$ or V_{CCI} ; $V_{CC(A)} = V_{CC(B)} = 1.1$ V to 3.6 V	[1]	-	-	1.4
ΔI_{CC}	additional supply current	A port; $V_{CC(A)} = V_{CC(B)} = 3.3$ V; A port at $V_{CC(A)} - 0.6$ V; DIR at $V_{CC(A)}$; B port = open	-	-	75	μ A
		B port; $V_{CC(A)} = V_{CC(B)} = 3.3$ V; B port at $V_{CC(B)} - 0.6$ V; DIR at GND; A port = open	-	-	75	μ A
		DIR input; $V_{CC(A)} = V_{CC(B)} = 3.3$ V; A port at $V_{CC(A)}$ or GND; B port = open; DIR at $V_{CC(A)} - 0.6$ V	-	-	75	μ A

[1] V_{CCI} is the supply voltage associated with the data input port.

[2] V_{CCO} is the supply voltage associated with the output port.

[3] For V_{CCI} values not specified in the data sheet: minimum $V_{IH} = 0.7 \times V_{CCI}$ and maximum $V_{IL} = 0.3 \times V_{CCI}$.

[4] For V_{CCI} values not specified in the data sheet: minimum $V_{IH} = 0.7 \times V_{CC(A)}$ and maximum $V_{IL} = 0.3 \times V_{CC(A)}$.

[5] All unused data inputs of the device must be held at V_{CCI} or GND to ensure proper device operation.

11. Dynamic characteristics

Table 8. Dynamic characteristics

Voltages are referenced to GND (ground = 0 V); for test circuit see [Figure 8](#).

Symbol	Parameter	Conditions	25 °C			-40 °C to +125 °C			Unit
			Min	Typ ^[1]	Max	Min	Max (85 °C)	Max (125 °C)	
$C_L = 5 \text{ pF}$; $V_{CC(A)} = 1.1 \text{ V to } 1.3 \text{ V}$									
t_{pd}	propagation delay	A to B or B to A; see Figure 6 ^[2]							
		$V_{CC(B)} = 1.1 \text{ V to } 1.3 \text{ V}$	2.8	15.4	28.0	2.4	28.3	31.2	ns
		$V_{CC(B)} = 1.4 \text{ V to } 1.6 \text{ V}$	2.8	10.2	16.2	2.6	17.5	19.3	ns
		$V_{CC(B)} = 1.65 \text{ V to } 1.95 \text{ V}$	2.4	8.1	13.0	2.2	14.4	15.9	ns
		$V_{CC(B)} = 2.3 \text{ V to } 2.7 \text{ V}$	2.5	6.3	10.0	2.1	10.7	11.8	ns
		$V_{CC(B)} = 3.0 \text{ V to } 3.6 \text{ V}$	2.3	5.6	9.0	1.9	9.7	10.7	ns
t_{dis}	disable time	DIR to A; see Figure 7 ^[3]							
		$V_{CC(B)} = 1.1 \text{ V to } 1.3 \text{ V}$	2.7	5.3	8.5	2.5	8.7	9.6	ns
		$V_{CC(B)} = 1.4 \text{ V to } 1.6 \text{ V}$	2.9	5.3	8.4	2.7	8.7	9.7	ns
		$V_{CC(B)} = 1.65 \text{ V to } 1.95 \text{ V}$	2.7	5.3	8.5	2.5	9.0	10.0	ns
		$V_{CC(B)} = 2.3 \text{ V to } 2.7 \text{ V}$	2.7	5.3	8.7	2.5	8.9	9.9	ns
		$V_{CC(B)} = 3.0 \text{ V to } 3.6 \text{ V}$	2.9	5.3	8.7	2.5	9.1	10.1	ns
		DIR to B; see Figure 7 ^[3]							
		$V_{CC(B)} = 1.1 \text{ V to } 1.3 \text{ V}$	6.1	13.2	22.1	5.4	23.4	25.8	ns
		$V_{CC(B)} = 1.4 \text{ V to } 1.6 \text{ V}$	5.0	9.3	13.9	4.4	15.2	16.7	ns
		$V_{CC(B)} = 1.65 \text{ V to } 1.95 \text{ V}$	4.2	8.1	12.3	3.6	13.5	14.9	ns
		$V_{CC(B)} = 2.3 \text{ V to } 2.7 \text{ V}$	3.3	6.3	9.3	2.9	10.2	11.2	ns
		$V_{CC(B)} = 3.0 \text{ V to } 3.6 \text{ V}$	3.6	6.3	9.2	3.2	9.7	10.7	ns
		$C_L = 5 \text{ pF}$; $V_{CC(A)} = 1.4 \text{ V to } 1.6 \text{ V}$							
t_{pd}	propagation delay	A to B or B to A; see Figure 6 ^[2]							
		$V_{CC(B)} = 1.1 \text{ V to } 1.3 \text{ V}$	2.5	14.5	26.6	2.2	27.1	29.9	ns
		$V_{CC(B)} = 1.4 \text{ V to } 1.6 \text{ V}$	2.5	9.4	14.5	2.3	15.9	17.5	ns
		$V_{CC(B)} = 1.65 \text{ V to } 1.95 \text{ V}$	2.1	7.4	11.2	1.9	12.7	14.0	ns
		$V_{CC(B)} = 2.3 \text{ V to } 2.7 \text{ V}$	2.2	5.5	8.0	1.8	8.9	9.8	ns
		$V_{CC(B)} = 3.0 \text{ V to } 3.6 \text{ V}$	2.0	4.7	6.8	1.6	7.6	8.4	ns

Table 8. Dynamic characteristics ...continued
 Voltages are referenced to GND (ground = 0 V); for test circuit see [Figure 8](#).

Symbol	Parameter	Conditions	25 °C			-40 °C to +125 °C			Unit
			Min	Typ ^[1]	Max	Min	Max (85 °C)	Max (125 °C)	
t _{dis}	disable time	DIR to A; see Figure 7 ^[3]							
		V _{CC(B)} = 1.1 V to 1.3 V	2.0	3.8	5.3	1.9	5.7	6.3	ns
		V _{CC(B)} = 1.4 V to 1.6 V	2.2	3.8	5.3	2.0	5.7	6.4	ns
		V _{CC(B)} = 1.65 V to 1.95 V	2.1	3.8	5.5	1.8	5.9	6.6	ns
		V _{CC(B)} = 2.3 V to 2.7 V	2.1	3.8	5.5	1.9	5.9	6.6	ns
		V _{CC(B)} = 3.0 V to 3.6 V	2.2	3.8	5.5	1.9	6.0	6.6	ns
		DIR to B; see Figure 7 ^[3]							
		V _{CC(B)} = 1.1 V to 1.3 V	5.7	12.7	21.0	5.2	22.3	24.6	ns
		V _{CC(B)} = 1.4 V to 1.6 V	4.7	8.7	12.7	4.1	14.1	15.5	ns
		V _{CC(B)} = 1.65 V to 1.95 V	3.9	7.4	10.9	3.3	12.3	13.5	ns
		V _{CC(B)} = 2.3 V to 2.7 V	3.0	5.6	7.8	2.6	8.8	9.7	ns
V _{CC(B)} = 3.0 V to 3.6 V	3.3	5.5	7.4	2.9	8.1	8.9	ns		

C_L = 5 pF; V_{CC(A)} = 1.65 V to 1.95 V

t _{pd}	propagation delay	A to B or B to A; see Figure 6 ^[2]							
		V _{CC(B)} = 1.1 V to 1.3 V	2.4	14.2	26.1	2.0	26.5	29.2	ns
		V _{CC(B)} = 1.4 V to 1.6 V	2.4	9.1	13.9	2.1	15.4	17.0	ns
		V _{CC(B)} = 1.65 V to 1.95 V	2.0	7.0	10.7	1.7	12.1	13.4	ns
		V _{CC(B)} = 2.3 V to 2.7 V	2.0	5.1	7.4	1.6	8.2	9.1	ns
		V _{CC(B)} = 3.0 V to 3.6 V	1.9	4.3	6.1	1.5	6.9	7.7	ns

t _{dis}	disable time	DIR to A; see Figure 7 ^[3]							
		V _{CC(B)} = 1.1 V to 1.3 V	2.0	3.5	4.8	1.8	5.2	5.8	ns
		V _{CC(B)} = 1.4 V to 1.6 V	2.1	3.5	4.8	1.9	5.2	5.7	ns
		V _{CC(B)} = 1.65 V to 1.95 V	2.0	3.5	5.0	1.8	5.4	6.0	ns
		V _{CC(B)} = 2.3 V to 2.7 V	2.0	3.5	4.9	1.8	5.4	6.0	ns
		V _{CC(B)} = 3.0 V to 3.6 V	2.1	3.5	4.9	1.8	5.4	6.0	ns
		DIR to B; see Figure 7 ^[3]							
		V _{CC(B)} = 1.1 V to 1.3 V	5.8	12.4	20.6	5.1	21.9	24.2	ns
		V _{CC(B)} = 1.4 V to 1.6 V	4.6	8.4	12.2	3.9	13.5	14.9	ns
		V _{CC(B)} = 1.65 V to 1.95 V	3.8	7.1	10.4	3.2	11.8	13.0	ns
		V _{CC(B)} = 2.3 V to 2.7 V	2.9	5.2	7.3	2.5	8.3	9.1	ns
V _{CC(B)} = 3.0 V to 3.6 V	3.1	5.1	6.9	2.7	7.5	8.3	ns		

C_L = 5 pF; V_{CC(A)} = 2.3 V to 2.7 V

t _{pd}	propagation delay	A to B or B to A; see Figure 6 ^[2]							
		V _{CC(B)} = 1.1 V to 1.3 V	2.4	13.6	25.5	2.0	25.9	28.6	ns
		V _{CC(B)} = 1.4 V to 1.6 V	2.3	8.5	13.3	2.1	14.7	16.2	ns
		V _{CC(B)} = 1.65 V to 1.95 V	1.9	6.5	10.0	1.7	11.4	12.5	ns
		V _{CC(B)} = 2.3 V to 2.7 V	1.9	4.6	6.7	1.6	7.5	8.3	ns
		V _{CC(B)} = 3.0 V to 3.6 V	1.8	3.8	5.3	1.4	6.2	6.8	ns

Table 8. Dynamic characteristics ...continued
 Voltages are referenced to GND (ground = 0 V); for test circuit see [Figure 8](#).

Symbol	Parameter	Conditions	25 °C			-40 °C to +125 °C			Unit
			Min	Typ ^[1]	Max	Min	Max (85 °C)	Max (125 °C)	
t _{dis}	disable time	DIR to A; see Figure 7 ^[3]							
		V _{CC(B)} = 1.1 V to 1.3 V	1.4	2.5	3.3	1.3	3.6	4.0	ns
		V _{CC(B)} = 1.4 V to 1.6 V	1.6	2.5	3.3	1.4	3.6	4.0	ns
		V _{CC(B)} = 1.65 V to 1.95 V	1.5	2.5	3.4	1.3	3.8	4.2	ns
		V _{CC(B)} = 2.3 V to 2.7 V	1.4	2.5	3.4	1.3	3.8	4.2	ns
		V _{CC(B)} = 3.0 V to 3.6 V	1.6	2.5	3.4	1.3	3.7	4.1	ns
		DIR to B; see Figure 7 ^[3]							
		V _{CC(B)} = 1.1 V to 1.3 V	5.8	12.3	20.4	5.1	21.8	24.0	ns
		V _{CC(B)} = 1.4 V to 1.6 V	4.5	8.3	11.9	4.0	13.2	14.5	ns
		V _{CC(B)} = 1.65 V to 1.95 V	3.7	7.0	10.0	3.2	11.3	12.5	ns
		V _{CC(B)} = 2.3 V to 2.7 V	2.8	5.0	6.8	2.5	7.8	8.6	ns
V _{CC(B)} = 3.0 V to 3.6 V	3.1	4.9	6.4	2.7	7.0	7.8	ns		

C_L = 5 pF; V_{CC(A)} = 3.0 V to 3.6 V

t _{pd}	propagation delay	A to B or B to A; see Figure 6 ^[2]							
		V _{CC(B)} = 1.1 V to 1.3 V	2.3	13.1	24.9	2.0	25.2	27.8	ns
		V _{CC(B)} = 1.4 V to 1.6 V	2.3	8.1	12.8	2.0	14.1	15.5	ns
		V _{CC(B)} = 1.65 V to 1.95 V	1.9	6.1	9.5	1.7	10.8	12.0	ns
		V _{CC(B)} = 2.3 V to 2.7 V	1.9	4.3	6.2	1.6	7.0	7.7	ns
		V _{CC(B)} = 3.0 V to 3.6 V	1.7	3.5	5.0	1.4	5.7	6.3	ns

t _{dis}	disable time	DIR to A; see Figure 7 ^[3]							
		V _{CC(B)} = 1.1 V to 1.3 V	1.7	2.8	3.5	1.5	3.8	4.2	ns
		V _{CC(B)} = 1.4 V to 1.6 V	1.8	2.8	3.5	1.7	3.8	4.2	ns
		V _{CC(B)} = 1.65 V to 1.95 V	1.7	2.8	3.6	1.5	4.0	4.4	ns
		V _{CC(B)} = 2.3 V to 2.7 V	1.7	2.8	3.6	1.5	3.9	4.4	ns
		V _{CC(B)} = 3.0 V to 3.6 V	1.8	2.8	3.6	1.5	3.9	4.3	ns
		DIR to B; see Figure 7 ^[3]							
		V _{CC(B)} = 1.1 V to 1.3 V	5.8	12.3	20.6	5.1	22.0	24.2	ns
		V _{CC(B)} = 1.4 V to 1.6 V	4.6	8.3	11.8	4.0	13.1	14.5	ns
		V _{CC(B)} = 1.65 V to 1.95 V	3.8	6.9	10.0	3.2	11.3	12.5	ns
		V _{CC(B)} = 2.3 V to 2.7 V	2.8	5.0	6.7	2.5	7.6	8.4	ns
V _{CC(B)} = 3.0 V to 3.6 V	3.1	4.9	6.3	2.7	6.9	7.6	ns		

C_L = 10 pF; V_{CC(A)} = 1.1 V to 1.3 V

t _{pd}	propagation delay	A to B or B to A; see Figure 6 ^[2]							
		V _{CC(B)} = 1.1 V to 1.3 V	3.0	16.2	29.8	2.7	30.2	33.3	ns
		V _{CC(B)} = 1.4 V to 1.6 V	3.0	10.8	17.5	2.7	18.6	20.5	ns
		V _{CC(B)} = 1.65 V to 1.95 V	3.1	8.7	13.5	2.8	14.6	16.1	ns
		V _{CC(B)} = 2.3 V to 2.7 V	2.7	6.8	10.5	2.4	11.2	12.4	ns
		V _{CC(B)} = 3.0 V to 3.6 V	2.7	6.1	9.6	2.4	10.1	11.1	ns

Table 8. Dynamic characteristics ...continued
 Voltages are referenced to GND (ground = 0 V); for test circuit see [Figure 8](#).

Symbol	Parameter	Conditions	25 °C			-40 °C to +125 °C			Unit
			Min	Typ ^[1]	Max	Min	Max (85 °C)	Max (125 °C)	
t _{dis}	disable time	DIR to A; see Figure 7 ^[3]							
		V _{CC(B)} = 1.1 V to 1.3 V	3.2	6.5	9.9	3.1	10.2	11.3	ns
		V _{CC(B)} = 1.4 V to 1.6 V	3.5	6.5	10.0	3.2	10.2	11.3	ns
		V _{CC(B)} = 1.65 V to 1.95 V	3.7	6.5	9.8	3.5	10.1	11.1	ns
		V _{CC(B)} = 2.3 V to 2.7 V	3.2	6.5	10.1	3.1	10.2	11.3	ns
		V _{CC(B)} = 3.0 V to 3.6 V	3.6	6.5	10.1	3.2	10.3	11.4	ns
		DIR to B; see Figure 7 ^[3]							
		V _{CC(B)} = 1.1 V to 1.3 V	6.4	14.3	23.5	5.8	24.8	27.4	ns
		V _{CC(B)} = 1.4 V to 1.6 V	5.3	10.2	15.4	4.6	16.6	18.4	ns
		V _{CC(B)} = 1.65 V to 1.95 V	5.2	9.2	13.6	4.7	14.7	16.2	ns
		V _{CC(B)} = 2.3 V to 2.7 V	3.6	7.1	10.1	3.2	11.0	12.1	ns
		V _{CC(B)} = 3.0 V to 3.6 V	4.4	7.6	10.8	3.8	11.4	12.5	ns

C_L = 10 pF; V_{CC(A)} = 1.4 V to 1.6 V

t _{pd}	propagation delay	A to B or B to A; see Figure 6 ^[2]							
		V _{CC(B)} = 1.1 V to 1.3 V	2.7	15.3	28.3	2.4	29.0	31.9	ns
		V _{CC(B)} = 1.4 V to 1.6 V	2.7	10.0	15.8	2.5	17.0	18.7	ns
		V _{CC(B)} = 1.65 V to 1.95 V	2.8	7.9	11.8	2.5	13.0	14.4	ns
		V _{CC(B)} = 2.3 V to 2.7 V	2.4	6.0	8.6	2.2	9.4	10.4	ns
		V _{CC(B)} = 3.0 V to 3.6 V	2.4	5.2	7.4	2.1	8.0	8.9	ns

t _{dis}	disable time	DIR to A; see Figure 7 ^[3]							
		V _{CC(B)} = 1.1 V to 1.3 V	2.5	4.7	6.4	2.3	6.8	7.6	ns
		V _{CC(B)} = 1.4 V to 1.6 V	2.7	4.7	6.5	2.4	6.9	7.6	ns
		V _{CC(B)} = 1.65 V to 1.95 V	2.9	4.7	6.5	2.6	6.9	7.6	ns
		V _{CC(B)} = 2.3 V to 2.7 V	2.5	4.7	6.5	2.3	6.9	7.6	ns
		V _{CC(B)} = 3.0 V to 3.6 V	2.8	4.7	6.6	2.4	6.9	7.7	ns
		DIR to B; see Figure 7 ^[3]							
		V _{CC(B)} = 1.1 V to 1.3 V	6.1	13.7	22.4	5.6	23.8	26.3	ns
		V _{CC(B)} = 1.4 V to 1.6 V	5.0	9.6	14.2	4.3	15.5	17.1	ns
		V _{CC(B)} = 1.65 V to 1.95 V	4.9	8.5	12.3	4.4	13.4	14.8	ns
		V _{CC(B)} = 2.3 V to 2.7 V	3.3	6.4	8.7	3.0	9.6	10.6	ns
		V _{CC(B)} = 3.0 V to 3.6 V	4.1	6.7	9.1	3.5	9.7	10.8	ns

C_L = 10 pF; V_{CC(A)} = 1.65 V to 1.95 V

t _{pd}	propagation delay	A to B or B to A; see Figure 6 ^[2]							
		V _{CC(B)} = 1.1 V to 1.3 V	2.6	15.0	27.8	2.3	28.3	31.2	ns
		V _{CC(B)} = 1.4 V to 1.6 V	2.6	9.7	15.2	2.3	16.5	18.2	ns
		V _{CC(B)} = 1.65 V to 1.95 V	2.7	7.5	11.2	2.3	12.4	13.7	ns
		V _{CC(B)} = 2.3 V to 2.7 V	2.3	5.6	7.9	2.0	8.8	9.7	ns
		V _{CC(B)} = 3.0 V to 3.6 V	2.3	4.8	6.7	1.9	7.4	8.2	ns

Table 8. Dynamic characteristics ...continued
 Voltages are referenced to GND (ground = 0 V); for test circuit see [Figure 8](#).

Symbol	Parameter	Conditions	25 °C			-40 °C to +125 °C			Unit
			Min	Typ ^[1]	Max	Min	Max (85 °C)	Max (125 °C)	
t _{dis}	disable time	DIR to A; see Figure 7 ^[3]							
		V _{CC(B)} = 1.1 V to 1.3 V	2.5	4.6	6.2	2.4	6.6	7.3	ns
		V _{CC(B)} = 1.4 V to 1.6 V	2.7	4.6	6.3	2.5	6.7	7.4	ns
		V _{CC(B)} = 1.65 V to 1.95 V	2.9	4.6	6.3	2.7	6.7	7.4	ns
		V _{CC(B)} = 2.3 V to 2.7 V	2.5	4.6	6.2	2.4	6.7	7.4	ns
		V _{CC(B)} = 3.0 V to 3.6 V	2.8	4.6	6.3	2.5	6.7	7.4	ns
		DIR to B; see Figure 7 ^[3]							
		V _{CC(B)} = 1.1 V to 1.3 V	6.1	13.5	22.1	5.4	23.4	25.8	ns
		V _{CC(B)} = 1.4 V to 1.6 V	5.0	9.3	13.6	4.2	14.9	16.5	ns
		V _{CC(B)} = 1.65 V to 1.95 V	4.8	8.3	11.8	4.2	13.0	14.3	ns
		V _{CC(B)} = 2.3 V to 2.7 V	3.2	6.0	8.1	2.8	9.1	10.0	ns
V _{CC(B)} = 3.0 V to 3.6 V	3.9	6.4	8.5	3.3	9.2	10.2	ns		

C_L = 10 pF; V_{CC(A)} = 2.3 V to 2.7 V

t _{pd}	propagation delay	A to B or B to A; see Figure 6 ^[2]							
		V _{CC(B)} = 1.1 V to 1.3 V	2.5	14.4	27.2	2.3	27.8	30.6	ns
		V _{CC(B)} = 1.4 V to 1.6 V	2.5	9.1	14.6	2.3	15.8	17.4	ns
		V _{CC(B)} = 1.65 V to 1.95 V	2.6	7.0	10.5	2.2	11.7	12.9	ns
		V _{CC(B)} = 2.3 V to 2.7 V	2.2	5.1	7.2	1.9	8.0	8.9	ns
		V _{CC(B)} = 3.0 V to 3.6 V	2.2	4.3	5.9	1.9	6.6	7.3	ns

t _{dis}	disable time	DIR to A; see Figure 7 ^[3]							
		V _{CC(B)} = 1.1 V to 1.3 V	1.8	3.3	4.2	1.7	4.6	5.1	ns
		V _{CC(B)} = 1.4 V to 1.6 V	2.0	3.3	4.4	1.8	4.7	5.2	ns
		V _{CC(B)} = 1.65 V to 1.95 V	2.1	3.3	4.4	2.0	4.7	5.2	ns
		V _{CC(B)} = 2.3 V to 2.7 V	1.8	3.3	4.3	1.7	4.7	5.2	ns
		V _{CC(B)} = 3.0 V to 3.6 V	2.1	3.3	4.4	1.8	4.7	5.2	ns
		DIR to B; see Figure 7 ^[3]							
		V _{CC(B)} = 1.1 V to 1.3 V	6.1	13.4	21.8	5.4	23.2	25.6	ns
		V _{CC(B)} = 1.4 V to 1.6 V	4.9	9.2	13.3	4.2	14.6	16.1	ns
		V _{CC(B)} = 1.65 V to 1.95 V	4.8	8.1	11.4	4.2	12.5	13.8	ns
		V _{CC(B)} = 2.3 V to 2.7 V	3.1	5.8	7.7	2.8	8.6	9.5	ns
V _{CC(B)} = 3.0 V to 3.6 V	3.9	6.2	8.0	3.3	8.7	9.6	ns		

C_L = 10 pF; V_{CC(A)} = 3.0 V to 3.6 V

t _{pd}	propagation delay	A to B or B to A; see Figure 6 ^[2]							
		V _{CC(B)} = 1.1 V to 1.3 V	2.5	14.0	26.6	2.2	27.0	29.8	ns
		V _{CC(B)} = 1.4 V to 1.6 V	2.5	8.7	14.0	2.3	15.1	16.7	ns
		V _{CC(B)} = 1.65 V to 1.95 V	2.5	6.6	10.1	2.2	11.2	12.4	ns
		V _{CC(B)} = 2.3 V to 2.7 V	2.2	4.8	6.8	1.9	7.5	8.3	ns
		V _{CC(B)} = 3.0 V to 3.6 V	2.1	4.0	5.5	1.9	6.1	6.8	ns

Table 8. Dynamic characteristics ...continued
 Voltages are referenced to GND (ground = 0 V); for test circuit see [Figure 8](#).

Symbol	Parameter	Conditions	25 °C			-40 °C to +125 °C			Unit
			Min	Typ ^[1]	Max	Min	Max (85 °C)	Max (125 °C)	
t _{dis}	disable time	DIR to A; see Figure 7 ^[3]							
		V _{CC(B)} = 1.1 V to 1.3 V	2.3	4.0	5.0	2.2	5.3	5.9	ns
		V _{CC(B)} = 1.4 V to 1.6 V	2.5	4.0	5.2	2.3	5.4	6.0	ns
		V _{CC(B)} = 1.65 V to 1.95 V	2.6	4.0	5.2	2.5	5.4	6.0	ns
		V _{CC(B)} = 2.3 V to 2.7 V	2.3	4.0	5.1	2.2	5.4	6.0	ns
		V _{CC(B)} = 3.0 V to 3.6 V	2.6	4.0	5.2	2.3	5.4	6.0	ns
		DIR to B; see Figure 7 ^[3]							
		V _{CC(B)} = 1.1 V to 1.3 V	6.2	13.5	22.0	5.5	23.4	25.8	ns
		V _{CC(B)} = 1.4 V to 1.6 V	4.9	9.2	13.2	4.2	14.6	16.1	ns
		V _{CC(B)} = 1.65 V to 1.95 V	4.8	8.1	11.3	4.3	12.4	13.7	ns
V _{CC(B)} = 2.3 V to 2.7 V	3.1	5.8	7.6	2.8	8.5	9.4	ns		
V _{CC(B)} = 3.0 V to 3.6 V	3.9	6.2	7.9	3.3	8.5	9.5	ns		

C_L = 15 pF; V_{CC(A)} = 1.1 V to 1.3 V

t _{pd}	propagation delay	A to B or B to A; see Figure 6 ^[2]							
		V _{CC(B)} = 1.1 V to 1.3 V	3.4	16.9	31.6	3.0	32.0	35.2	ns
		V _{CC(B)} = 1.4 V to 1.6 V	3.7	11.3	18.2	3.1	19.5	21.5	ns
		V _{CC(B)} = 1.65 V to 1.95 V	3.2	9.1	14.3	3.0	15.6	17.2	ns
		V _{CC(B)} = 2.3 V to 2.7 V	3.2	7.3	11.2	2.8	12.0	13.2	ns
		V _{CC(B)} = 3.0 V to 3.6 V	3.1	6.5	10.2	2.6	10.7	11.8	ns

t _{dis}	disable time	DIR to A; see Figure 7 ^[3]							
		V _{CC(B)} = 1.1 V to 1.3 V	3.9	7.6	11.4	3.8	11.7	12.9	ns
		V _{CC(B)} = 1.4 V to 1.6 V	4.5	7.6	11.3	4.1	11.7	12.9	ns
		V _{CC(B)} = 1.65 V to 1.95 V	4.2	7.6	11.3	4.1	11.7	12.9	ns
		V _{CC(B)} = 2.3 V to 2.7 V	3.9	7.6	11.7	3.8	11.9	13.1	ns
		V _{CC(B)} = 3.0 V to 3.6 V	4.5	7.6	11.7	4.1	11.9	13.1	ns
		DIR to B; see Figure 7 ^[3]							
		V _{CC(B)} = 1.1 V to 1.3 V	7.2	15.4	24.9	6.5	26.3	29.0	ns
		V _{CC(B)} = 1.4 V to 1.6 V	6.3	11.1	16.3	5.4	17.7	19.5	ns
		V _{CC(B)} = 1.65 V to 1.95 V	5.7	10.4	15.0	5.2	16.2	17.9	ns
V _{CC(B)} = 2.3 V to 2.7 V	4.1	7.9	11.4	3.8	12.1	13.4	ns		
V _{CC(B)} = 3.0 V to 3.6 V	5.3	8.8	12.2	4.9	12.7	14.1	ns		

C_L = 15 pF; V_{CC(A)} = 1.4 V to 1.6 V

t _{pd}	propagation delay	A to B or B to A; see Figure 6 ^[2]							
		V _{CC(B)} = 1.1 V to 1.3 V	3.1	16.1	30.1	2.8	30.7	33.8	ns
		V _{CC(B)} = 1.4 V to 1.6 V	3.4	10.5	16.5	2.8	17.9	19.7	ns
		V _{CC(B)} = 1.65 V to 1.95 V	3.0	8.4	12.6	2.7	13.9	15.4	ns
		V _{CC(B)} = 2.3 V to 2.7 V	2.9	6.4	9.3	2.5	10.1	11.2	ns
		V _{CC(B)} = 3.0 V to 3.6 V	2.8	5.6	8.0	2.3	8.7	9.6	ns

Table 8. Dynamic characteristics ...continued
 Voltages are referenced to GND (ground = 0 V); for test circuit see [Figure 8](#).

Symbol	Parameter	Conditions	25 °C			-40 °C to +125 °C			Unit
			Min	Typ ^[1]	Max	Min	Max (85 °C)	Max (125 °C)	
t _{dis}	disable time	DIR to A; see Figure 7 ^[3]							
		V _{CC(B)} = 1.1 V to 1.3 V	3.1	5.6	7.6	2.9	8.0	8.9	ns
		V _{CC(B)} = 1.4 V to 1.6 V	3.5	5.6	7.5	3.1	8.0	8.8	ns
		V _{CC(B)} = 1.65 V to 1.95 V	3.3	5.6	7.6	3.1	8.0	8.9	ns
		V _{CC(B)} = 2.3 V to 2.7 V	3.1	5.6	7.7	2.9	8.1	9.0	ns
		V _{CC(B)} = 3.0 V to 3.6 V	3.5	5.6	7.8	3.1	8.1	9.0	ns
		DIR to B; see Figure 7 ^[3]							
		V _{CC(B)} = 1.1 V to 1.3 V	6.9	14.9	23.8	6.4	25.3	27.9	ns
		V _{CC(B)} = 1.4 V to 1.6 V	6.0	10.5	15.1	5.2	16.6	18.3	ns
		V _{CC(B)} = 1.65 V to 1.95 V	5.4	9.7	13.7	5.0	15.0	16.5	ns
		V _{CC(B)} = 2.3 V to 2.7 V	3.8	7.2	9.9	3.5	10.7	11.9	ns
V _{CC(B)} = 3.0 V to 3.6 V	5.0	8.0	10.5	4.6	11.1	12.3	ns		

C_L = 15 pF; V_{CC(A)} = 1.65 V to 1.95 V

t _{pd}	propagation delay	A to B or B to A; see Figure 6 ^[2]							
		V _{CC(B)} = 1.1 V to 1.3 V	3.0	15.8	29.6	2.6	30.1	33.2	ns
		V _{CC(B)} = 1.4 V to 1.6 V	3.2	10.2	15.9	2.6	17.4	19.2	ns
		V _{CC(B)} = 1.65 V to 1.95 V	2.8	8.0	12.0	2.5	13.4	14.8	ns
		V _{CC(B)} = 2.3 V to 2.7 V	2.8	6.0	8.6	2.3	9.5	10.5	ns
		V _{CC(B)} = 3.0 V to 3.6 V	2.6	5.2	7.3	2.2	8.0	8.9	ns

t _{dis}	disable time	DIR to A; see Figure 7 ^[3]							
		V _{CC(B)} = 1.1 V to 1.3 V	3.2	5.8	7.6	3.1	8.0	8.9	ns
		V _{CC(B)} = 1.4 V to 1.6 V	3.7	5.8	7.6	3.3	8.1	8.9	ns
		V _{CC(B)} = 1.65 V to 1.95 V	3.5	5.8	7.7	3.3	8.1	9.0	ns
		V _{CC(B)} = 2.3 V to 2.7 V	3.2	5.8	7.8	3.1	8.2	9.0	ns
		V _{CC(B)} = 3.0 V to 3.6 V	3.7	5.8	7.8	3.4	8.1	9.0	ns
		DIR to B; see Figure 7 ^[3]							
		V _{CC(B)} = 1.1 V to 1.3 V	6.9	14.7	23.4	6.2	24.9	27.4	ns
		V _{CC(B)} = 1.4 V to 1.6 V	5.9	10.2	14.6	5.0	16.0	17.7	ns
		V _{CC(B)} = 1.65 V to 1.95 V	5.3	9.4	13.2	4.8	14.5	16.0	ns
		V _{CC(B)} = 2.3 V to 2.7 V	3.7	6.8	9.4	3.4	10.2	11.3	ns
V _{CC(B)} = 3.0 V to 3.6 V	4.9	7.6	9.9	4.4	10.6	11.7	ns		

C_L = 15 pF; V_{CC(A)} = 2.3 V to 2.7 V

t _{pd}	propagation delay	A to B or B to A; see Figure 6 ^[2]							
		V _{CC(B)} = 1.1 V to 1.3 V	3.0	15.2	29.0	2.6	29.5	32.5	ns
		V _{CC(B)} = 1.4 V to 1.6 V	3.1	9.6	15.3	2.6	16.7	18.4	ns
		V _{CC(B)} = 1.65 V to 1.95 V	2.7	7.5	11.3	2.5	12.6	13.9	ns
		V _{CC(B)} = 2.3 V to 2.7 V	2.7	5.5	7.9	2.3	8.7	9.6	ns
		V _{CC(B)} = 3.0 V to 3.6 V	2.5	4.7	6.5	2.1	7.2	8.0	ns

Table 8. Dynamic characteristics ...continued
 Voltages are referenced to GND (ground = 0 V); for test circuit see [Figure 8](#).

Symbol	Parameter	Conditions	25 °C			-40 °C to +125 °C			Unit
			Min	Typ ^[1]	Max	Min	Max (85 °C)	Max (125 °C)	
t _{dis}	disable time	DIR to A; see Figure 7 ^[3]							
		V _{CC(B)} = 1.1 V to 1.3 V	2.4	4.1	5.2	2.2	5.6	6.2	ns
		V _{CC(B)} = 1.4 V to 1.6 V	2.7	4.1	5.3	2.4	5.7	6.3	ns
		V _{CC(B)} = 1.65 V to 1.95 V	2.5	4.1	5.4	2.4	5.7	6.3	ns
		V _{CC(B)} = 2.3 V to 2.7 V	2.4	4.1	5.4	2.2	5.7	6.3	ns
		V _{CC(B)} = 3.0 V to 3.6 V	2.7	4.1	5.3	2.4	5.6	6.2	ns
		DIR to B; see Figure 7 ^[3]							
		V _{CC(B)} = 1.1 V to 1.3 V	6.9	14.6	23.2	6.2	24.7	27.2	ns
		V _{CC(B)} = 1.4 V to 1.6 V	5.9	10.1	14.2	5.0	15.6	17.3	ns
		V _{CC(B)} = 1.65 V to 1.95 V	5.3	9.2	12.8	4.8	14.0	15.5	ns
		V _{CC(B)} = 2.3 V to 2.7 V	3.7	6.7	8.9	3.4	9.8	10.8	ns
		V _{CC(B)} = 3.0 V to 3.6 V	4.8	7.4	9.4	4.4	10.1	11.2	ns

C_L = 15 pF; V_{CC(A)} = 3.0 V to 3.6 V

t _{pd}	propagation delay	A to B or B to A; see Figure 6 ^[2]							
		V _{CC(B)} = 1.1 V to 1.3 V	2.9	14.7	28.3	2.6	28.8	31.7	ns
		V _{CC(B)} = 1.4 V to 1.6 V	3.1	9.2	14.7	2.6	16.0	17.7	ns
		V _{CC(B)} = 1.65 V to 1.95 V	2.7	7.1	10.9	2.4	12.1	13.4	ns
		V _{CC(B)} = 2.3 V to 2.7 V	2.7	5.2	7.4	2.2	8.2	9.1	ns
		V _{CC(B)} = 3.0 V to 3.6 V	2.5	4.5	6.1	2.1	6.8	7.5	ns

t _{dis}	disable time	DIR to A; see Figure 7 ^[3]							
		V _{CC(B)} = 1.1 V to 1.3 V	3.1	5.3	6.5	3.0	6.9	7.6	ns
		V _{CC(B)} = 1.4 V to 1.6 V	3.5	5.3	6.6	3.2	7.0	7.7	ns
		V _{CC(B)} = 1.65 V to 1.95 V	3.3	5.3	6.7	3.2	7.0	7.8	ns
		V _{CC(B)} = 2.3 V to 2.7 V	3.1	5.3	6.8	3.0	7.1	7.8	ns
		V _{CC(B)} = 3.0 V to 3.6 V	3.5	5.3	6.6	3.2	6.9	7.6	ns
		DIR to B; see Figure 7 ^[3]							
		V _{CC(B)} = 1.1 V to 1.3 V	6.9	14.6	23.4	6.3	24.9	27.4	ns
		V _{CC(B)} = 1.4 V to 1.6 V	5.9	10.1	14.2	5.0	15.6	17.2	ns
		V _{CC(B)} = 1.65 V to 1.95 V	5.3	9.2	12.7	4.8	13.9	15.4	ns
		V _{CC(B)} = 2.3 V to 2.7 V	3.7	6.6	8.8	3.4	9.6	10.6	ns
		V _{CC(B)} = 3.0 V to 3.6 V	4.8	7.4	9.3	4.4	10.0	11.0	ns

C_L = 30 pF; V_{CC(A)} = 1.1 V to 1.3 V

t _{pd}	propagation delay	A to B or B to A; see Figure 6 ^[2]							
		V _{CC(B)} = 1.1 V to 1.3 V	4.2	19.1	36.0	3.8	36.8	40.5	ns
		V _{CC(B)} = 1.4 V to 1.6 V	4.5	12.8	20.6	4.0	22.0	24.2	ns
		V _{CC(B)} = 1.65 V to 1.95 V	4.2	10.4	16.2	3.8	17.4	19.2	ns
		V _{CC(B)} = 2.3 V to 2.7 V	4.0	8.3	12.4	3.5	13.2	14.5	ns
		V _{CC(B)} = 3.0 V to 3.6 V	4.0	7.5	11.5	3.7	12.5	13.8	ns

Table 8. Dynamic characteristics ...continued
 Voltages are referenced to GND (ground = 0 V); for test circuit see [Figure 8](#).

Symbol	Parameter	Conditions	25 °C			-40 °C to +125 °C			Unit
			Min	Typ ^[1]	Max	Min	Max (85 °C)	Max (125 °C)	
t _{dis}	disable time	DIR to A; see Figure 7 ^[3]							
		V _{CC(B)} = 1.1 V to 1.3 V	5.6	11.0	15.7	5.5	16.2	17.9	ns
		V _{CC(B)} = 1.4 V to 1.6 V	6.1	11.0	15.6	6.0	15.9	17.5	ns
		V _{CC(B)} = 1.65 V to 1.95 V	6.6	11.0	15.5	6.5	15.8	17.4	ns
		V _{CC(B)} = 2.3 V to 2.7 V	5.6	11.0	15.6	5.5	15.8	17.5	ns
		V _{CC(B)} = 3.0 V to 3.6 V	7.0	11.0	15.9	6.6	16.7	18.4	ns
		DIR to B; see Figure 7 ^[3]							
		V _{CC(B)} = 1.1 V to 1.3 V	8.7	18.9	29.0	8.1	30.5	33.6	ns
		V _{CC(B)} = 1.4 V to 1.6 V	7.3	13.8	19.3	6.8	20.7	22.8	ns
		V _{CC(B)} = 1.65 V to 1.95 V	8.1	13.7	19.2	7.7	20.3	22.4	ns
		V _{CC(B)} = 2.3 V to 2.7 V	5.2	10.3	14.0	4.9	14.7	16.2	ns
		V _{CC(B)} = 3.0 V to 3.6 V	8.1	12.5	16.5	7.5	18.0	19.9	ns

C_L = 30 pF; V_{CC(A)} = 1.4 V to 1.6 V

t _{pd}	propagation delay	A to B or B to A; see Figure 6 ^[2]							
		V _{CC(B)} = 1.1 V to 1.3 V	4.0	18.2	34.5	3.5	35.5	39.1	ns
		V _{CC(B)} = 1.4 V to 1.6 V	4.2	12.0	18.9	3.7	20.3	22.4	ns
		V _{CC(B)} = 1.65 V to 1.95 V	3.9	9.6	14.4	3.5	15.8	17.4	ns
		V _{CC(B)} = 2.3 V to 2.7 V	3.8	7.5	10.4	3.2	11.4	12.6	ns
		V _{CC(B)} = 3.0 V to 3.6 V	3.7	6.7	9.3	3.4	10.4	11.4	ns

t _{dis}	disable time	DIR to A; see Figure 7 ^[3]							
		V _{CC(B)} = 1.1 V to 1.3 V	4.4	8.3	10.8	4.3	11.4	12.6	ns
		V _{CC(B)} = 1.4 V to 1.6 V	4.8	8.3	10.7	4.6	11.2	12.3	ns
		V _{CC(B)} = 1.65 V to 1.95 V	5.2	8.3	10.8	5.0	11.2	12.4	ns
		V _{CC(B)} = 2.3 V to 2.7 V	4.4	8.3	10.8	4.3	11.1	12.3	ns
		V _{CC(B)} = 3.0 V to 3.6 V	5.5	8.3	11.0	5.1	11.8	13.0	ns
		DIR to B; see Figure 7 ^[3]							
		V _{CC(B)} = 1.1 V to 1.3 V	8.4	18.3	27.9	7.9	29.5	32.5	ns
		V _{CC(B)} = 1.4 V to 1.6 V	7.1	13.2	18.2	6.6	19.6	21.6	ns
		V _{CC(B)} = 1.65 V to 1.95 V	7.8	13.1	17.9	7.4	19.1	21.0	ns
		V _{CC(B)} = 2.3 V to 2.7 V	4.9	9.6	12.6	4.6	13.4	14.8	ns
		V _{CC(B)} = 3.0 V to 3.6 V	7.7	11.7	14.8	7.2	16.3	18.0	ns

C_L = 30 pF; V_{CC(A)} = 1.65 V to 1.95 V

t _{pd}	propagation delay	A to B or B to A; see Figure 6 ^[2]							
		V _{CC(B)} = 1.1 V to 1.3 V	3.9	18.0	34.0	3.4	34.9	38.4	ns
		V _{CC(B)} = 1.4 V to 1.6 V	4.1	11.7	18.3	3.5	19.8	21.9	ns
		V _{CC(B)} = 1.65 V to 1.95 V	3.8	9.2	13.9	3.4	15.2	16.8	ns
		V _{CC(B)} = 2.3 V to 2.7 V	3.6	7.1	9.8	3.1	10.8	11.9	ns
		V _{CC(B)} = 3.0 V to 3.6 V	3.5	6.3	8.6	3.2	9.7	10.7	ns

Table 8. Dynamic characteristics ...continued
 Voltages are referenced to GND (ground = 0 V); for test circuit see [Figure 8](#).

Symbol	Parameter	Conditions	25 °C			-40 °C to +125 °C			Unit
			Min	Typ ^[1]	Max	Min	Max (85 °C)	Max (125 °C)	
t _{dis}	disable time	DIR to A; see Figure 7 ^[3]							
		V _{CC(B)} = 1.1 V to 1.3 V	5.0	9.2	11.7	4.8	12.3	13.6	ns
		V _{CC(B)} = 1.4 V to 1.6 V	5.4	9.2	11.7	5.3	12.1	13.4	ns
		V _{CC(B)} = 1.65 V to 1.95 V	5.8	9.1	11.9	5.7	12.3	13.6	ns
		V _{CC(B)} = 2.3 V to 2.7 V	5.0	9.1	11.7	4.8	12.1	13.4	ns
		V _{CC(B)} = 3.0 V to 3.6 V	6.2	9.2	11.9	5.8	12.7	14.1	ns
		DIR to B; see Figure 7 ^[3]							
		V _{CC(B)} = 1.1 V to 1.3 V	8.4	18.1	27.6	7.8	29.1	32.0	ns
		V _{CC(B)} = 1.4 V to 1.6 V	7.0	12.9	17.7	6.4	19.1	21.0	ns
		V _{CC(B)} = 1.65 V to 1.95 V	7.7	12.8	17.4	7.2	18.6	20.6	ns
		V _{CC(B)} = 2.3 V to 2.7 V	4.8	9.3	12.0	4.5	12.9	14.2	ns
V _{CC(B)} = 3.0 V to 3.6 V	7.6	11.3	14.2	7.0	15.8	17.4	ns		

C_L = 30 pF; V_{CC(A)} = 2.3 V to 2.7 V

t _{pd}	propagation delay	A to B or B to A; see Figure 6 ^[2]							
		V _{CC(B)} = 1.1 V to 1.3 V	3.8	17.4	33.4	3.4	34.3	37.8	ns
		V _{CC(B)} = 1.4 V to 1.6 V	4.0	11.1	17.7	3.5	19.1	21.1	ns
		V _{CC(B)} = 1.65 V to 1.95 V	3.7	8.7	13.2	3.3	14.4	15.9	ns
		V _{CC(B)} = 2.3 V to 2.7 V	3.4	6.5	9.1	3.0	10.0	11.1	ns
		V _{CC(B)} = 3.0 V to 3.6 V	3.5	5.7	7.8	3.1	8.9	9.8	ns

t _{dis}	disable time	DIR to A; see Figure 7 ^[3]							
		V _{CC(B)} = 1.1 V to 1.3 V	3.6	6.5	8.1	3.5	8.5	9.4	ns
		V _{CC(B)} = 1.4 V to 1.6 V	3.9	6.5	8.1	3.8	8.5	9.4	ns
		V _{CC(B)} = 1.65 V to 1.95 V	4.2	6.5	8.3	4.1	8.6	9.5	ns
		V _{CC(B)} = 2.3 V to 2.7 V	3.6	6.5	8.2	3.5	8.5	9.4	ns
		V _{CC(B)} = 3.0 V to 3.6 V	4.5	6.5	8.2	4.2	8.9	9.8	ns
		DIR to B; see Figure 7 ^[3]							
		V _{CC(B)} = 1.1 V to 1.3 V	8.4	18.0	27.4	7.8	28.8	31.8	ns
		V _{CC(B)} = 1.4 V to 1.6 V	7.0	12.8	17.3	6.4	18.7	20.6	ns
		V _{CC(B)} = 1.65 V to 1.95 V	7.7	12.6	17.0	7.2	18.2	20.0	ns
		V _{CC(B)} = 2.3 V to 2.7 V	4.8	9.1	11.6	4.5	12.4	13.7	ns
V _{CC(B)} = 3.0 V to 3.6 V	7.6	11.1	13.7	7.0	15.3	16.9	ns		

C_L = 30 pF; V_{CC(A)} = 3.0 V to 3.6 V

t _{pd}	propagation delay	A to B or B to A; see Figure 6 ^[2]							
		V _{CC(B)} = 1.1 V to 1.3 V	3.8	16.9	32.8	3.3	33.5	36.9	ns
		V _{CC(B)} = 1.4 V to 1.6 V	3.9	10.7	17.1	3.5	18.5	20.4	ns
		V _{CC(B)} = 1.65 V to 1.95 V	3.7	8.3	12.7	3.3	13.9	15.4	ns
		V _{CC(B)} = 2.3 V to 2.7 V	3.2	6.3	8.6	2.9	9.5	10.5	ns
		V _{CC(B)} = 3.0 V to 3.6 V	3.4	5.5	7.4	3.1	8.4	9.3	ns

Table 8. Dynamic characteristics ...continued
 Voltages are referenced to GND (ground = 0 V); for test circuit see [Figure 8](#).

Symbol	Parameter	Conditions	25 °C			-40 °C to +125 °C			Unit
			Min	Typ ^[1]	Max	Min	Max (85 °C)	Max (125 °C)	
t _{dis}	disable time	DIR to A; see Figure 7 ^[3]							
		V _{CC(B)} = 1.1 V to 1.3 V	5.0	9.0	11.0	4.9	11.5	12.7	ns
		V _{CC(B)} = 1.4 V to 1.6 V	5.4	9.0	11.1	5.3	11.4	12.6	ns
		V _{CC(B)} = 1.65 V to 1.95 V	5.9	9.0	11.3	5.7	11.6	12.8	ns
		V _{CC(B)} = 2.3 V to 2.7 V	5.0	9.0	11.2	4.9	11.4	12.6	ns
		V _{CC(B)} = 3.0 V to 3.6 V	6.2	9.0	11.2	5.9	11.9	13.2	ns
		DIR to B; see Figure 7 ^[3]							
		V _{CC(B)} = 1.1 V to 1.3 V	8.4	18.1	27.6	7.8	29.1	32.0	ns
		V _{CC(B)} = 1.4 V to 1.6 V	7.0	12.8	17.3	6.4	18.6	20.6	ns
		V _{CC(B)} = 1.65 V to 1.95 V	7.7	12.6	17.0	7.2	18.1	19.9	ns
		V _{CC(B)} = 2.3 V to 2.7 V	4.8	9.0	11.5	4.5	12.3	13.6	ns
		V _{CC(B)} = 3.0 V to 3.6 V	7.6	11.1	13.6	7.0	15.1	16.7	ns

Table 8. Dynamic characteristics ...continued

Voltages are referenced to GND (ground = 0 V); for test circuit see [Figure 8](#).

Symbol	Parameter	Conditions	25 °C			-40 °C to +125 °C			Unit
			Min	Typ ^[1]	Max	Min	Max (85 °C)	Max (125 °C)	
C_L = 5 pF, 10 pF, 15 pF and 30 pF									
C _{PD}	power dissipation capacitance	A port; (direction A to B)	[4][5]						
		V _{CC(A)} = V _{CC(B)} = 1.2 V	-	0.6	-	-	-	-	pF
		V _{CC(A)} = V _{CC(B)} = 1.5 V	-	0.7	-	-	-	-	pF
		V _{CC(A)} = V _{CC(B)} = 1.8 V	-	0.7	-	-	-	-	pF
		V _{CC(A)} = V _{CC(B)} = 2.5 V	-	0.9	-	-	-	-	pF
		V _{CC(A)} = V _{CC(B)} = 3.3 V	-	1.1	-	-	-	-	pF
		A port; (direction B to A)	[4][5]						
		V _{CC(A)} = V _{CC(B)} = 1.2 V	-	3.7	-	-	-	-	pF
		V _{CC(A)} = V _{CC(B)} = 1.5 V	-	3.8	-	-	-	-	pF
		V _{CC(A)} = V _{CC(B)} = 1.8 V	-	4.0	-	-	-	-	pF
		V _{CC(A)} = V _{CC(B)} = 2.5 V	-	4.6	-	-	-	-	pF
		V _{CC(A)} = V _{CC(B)} = 3.3 V	-	5.2	-	-	-	-	pF
		B port; (direction A to B)	[4][5]						
		V _{CC(A)} = V _{CC(B)} = 1.2 V	-	3.7	-	-	-	-	pF
		V _{CC(A)} = V _{CC(B)} = 1.5 V	-	3.8	-	-	-	-	pF
		V _{CC(A)} = V _{CC(B)} = 1.8 V	-	4.0	-	-	-	-	pF
		V _{CC(A)} = V _{CC(B)} = 2.5 V	-	4.6	-	-	-	-	pF
		V _{CC(A)} = V _{CC(B)} = 3.3 V	-	5.2	-	-	-	-	pF
		B port; (direction B to A)	[4][5]						
		V _{CC(A)} = V _{CC(B)} = 1.2 V	-	0.6	-	-	-	-	pF
		V _{CC(A)} = V _{CC(B)} = 1.5 V	-	0.7	-	-	-	-	pF
		V _{CC(A)} = V _{CC(B)} = 1.8 V	-	0.7	-	-	-	-	pF
		V _{CC(A)} = V _{CC(B)} = 2.5 V	-	0.9	-	-	-	-	pF
		V _{CC(A)} = V _{CC(B)} = 3.3 V	-	1.1	-	-	-	-	pF

- [1] All typical values are measured at nominal V_{CC(A)} and V_{CC(B)}.
- [2] t_{pd} is the same as t_{PLH} and t_{PHL}.
- [3] t_{dis} is the same as t_{PLZ} and t_{PHZ}.
- [4] C_{PD} is used to determine the dynamic power dissipation (P_D in μW).
 $P_D = C_{PD} \times V_{CC}^2 \times f_i \times N + \Sigma(C_L \times V_{CC}^2 \times f_o)$ where:
 f_i = input frequency in MHz;
 f_o = output frequency in MHz;
 C_L = load capacitance in pF;
 V_{CC} = supply voltage in V;
 N = number of inputs switching;
 Σ(C_L × V_{CC}² × f_o) = sum of the outputs.
- [5] f_i = 1 MHz; V_I = GND to V_{CC}

12. Waveforms

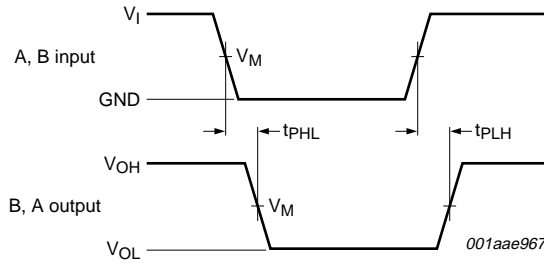

Measurement points are given in [Table 9](#).
 V_{OL} and V_{OH} are typical output voltage drops that occur with the output load.

Fig 6. The data input (A, B) to output (B, A) propagation delay times

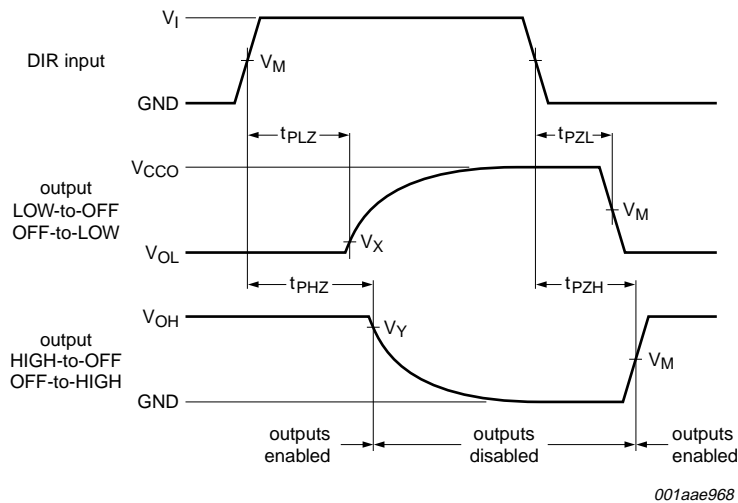

Measurement points are given in [Table 9](#).
 V_{OL} and V_{OH} are typical output voltage drops that occur with the output load.

Fig 7. Enable and disable times

Table 9. Measurement points

Supply voltage	Input ^[1]	Output ^[2]		
	V_M	V_M	V_X	V_Y
1.1 V to 1.6 V	$0.5 \times V_{CC1}$	$0.5 \times V_{CC0}$	$V_{OL} + 0.1 \text{ V}$	$V_{OH} - 0.1 \text{ V}$
1.65 V to 2.7 V	$0.5 \times V_{CC1}$	$0.5 \times V_{CC0}$	$V_{OL} + 0.15 \text{ V}$	$V_{OH} - 0.15 \text{ V}$
3.0 V to 3.6 V	$0.5 \times V_{CC1}$	$0.5 \times V_{CC0}$	$V_{OL} + 0.3 \text{ V}$	$V_{OH} - 0.3 \text{ V}$

[1] V_{CC1} is the supply voltage associated with the data input port.

[2] V_{CC0} is the supply voltage associated with the output port.

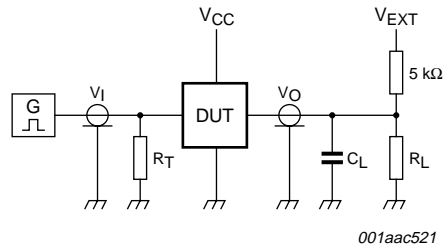

Test data is given in [Table 10](#).
 R_L = Load resistance.
 C_L = Load capacitance including jig and probe capacitance.
 R_T = Termination resistance.
 V_{EXT} = External voltage for measuring switching times.

Fig 8. Test circuit for measuring switching times

Table 10. Test data

Supply voltage	Input		Load		V_{EXT}		
$V_{CC(A)}, V_{CC(B)}$	V_I ^[1]	$t_r = t_f$	C_L	R_L ^[2]	t_{PLH}, t_{PHL}	t_{PZH}, t_{PHZ}	t_{PZL}, t_{PLZ} ^[3]
1.1 V to 3.6 V	V_{CCI}	≤ 3.0 ns	5 pF, 10 pF, 15 pF and 30 pF	5 kΩ or 1 MΩ	open	GND	$2 \times V_{CCO}$

- [1] V_{CCI} is the supply voltage associated with the data input port.
- [2] For measuring enable and disable times $R_L = 5$ kΩ, for measuring propagation delays, setup and hold times and pulse width $R_L = 1$ MΩ.
- [3] V_{CCO} is the supply voltage associated with the output port.

13. Application information

13.1 Unidirectional logic level-shifting application

The circuit given in [Figure 9](#) is an example of the 74AUP1T45 being used in an unidirectional logic level-shifting application.

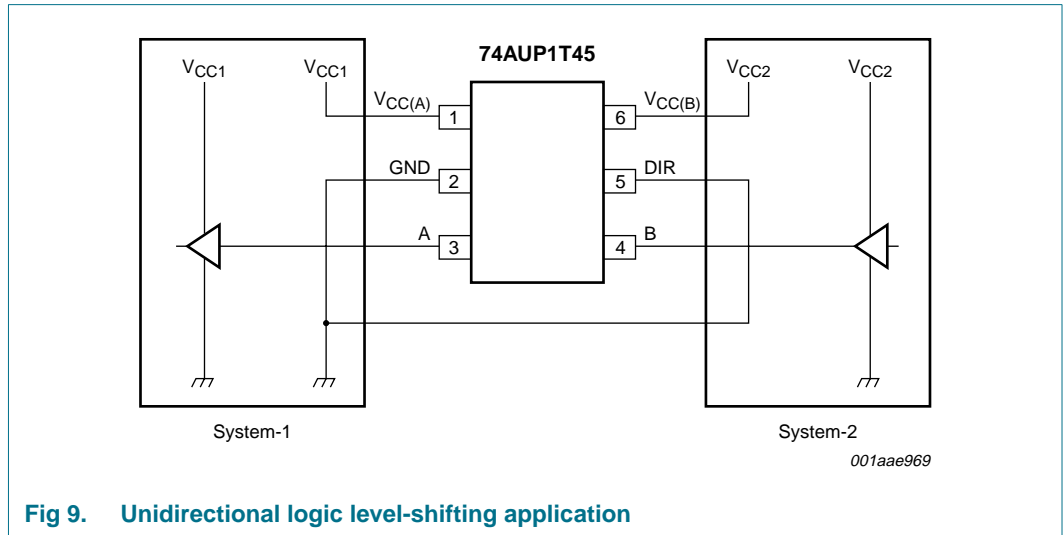

Fig 9. Unidirectional logic level-shifting application

Table 11. Description unidirectional logic level-shifting application

Pin	Name	Function	Description
1	V _{CC(A)}	V _{CC1}	supply voltage of system-1 (1.1 V to 3.6 V)
2	GND	GND	device ground (0 V)
3	A	OUT	output level depends on V _{CC1} voltage
4	B	IN	input threshold value depends on V _{CC2} voltage
5	DIR	DIR	the GND (LOW level) determines B port to A port direction
6	V _{CC(B)}	V _{CC2}	supply voltage of system-2 (1.1 V to 3.6 V)

13.2 Bidirectional logic level-shifting application

Figure 10 shows the 74AUP1T45 being used in a bidirectional logic level-shifting application. Since the device does not have an output enable (OE) pin, the system designer should take precautions to avoid bus contention between system-1 and system-2 when changing directions.

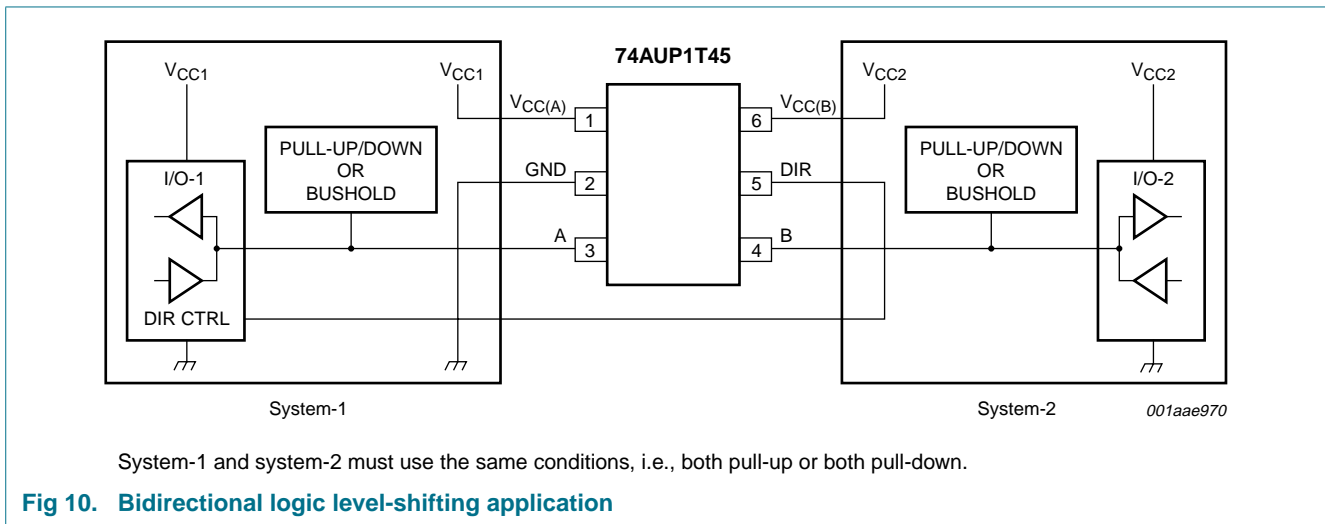

Table 12 gives a sequence that will illustrate data transmission from system-1 to system-2 and then from system-2 to system-1.

Table 12. Description bidirectional logic level-shifting application^{[1][2]}

State	DIR CTRL	I/O-1	I/O-2	Description
1	H	output	input	system-1 data to system-2
2	H	Z	Z	system-2 is getting ready to send data to system-1. I/O-1 and I/O-2 are disabled. The bus-line state depends on the pull-up or pull-down.
3	L	Z	Z	DIR bit is flipped. I/O-1 and I/O-2 still are disabled. The bus-line state depends on the pull-up or pull-down.
4	L	input	output	system-2 data to system-1

[1] System-1 and system-2 must use the same conditions, i.e., both pull-up or both pull-down.

[2] H = HIGH voltage level;
 L = LOW voltage level;
 Z = high-impedance OFF-state.

13.3 Power-up considerations

A proper power-up sequence always should be followed to avoid excessive supply current, bus contention, oscillations, or other anomalies. Take the following precautions to guard against such power-up problems:

- Connect ground before any supply voltage is applied.
- Power-up $V_{CC(A)}$.
- $V_{CC(B)}$ can be ramped up along with or after $V_{CC(A)}$.

13.4 Enable times

Calculate the enable times for the 74AUP1T45 using the following formulas:

- $t_{PZH} \text{ (DIR to A)} = t_{PLZ} \text{ (DIR to B)} + t_{PLH} \text{ (B to A)}$
- $t_{PZL} \text{ (DIR to A)} = t_{PHZ} \text{ (DIR to B)} + t_{PHL} \text{ (B to A)}$
- $t_{PZH} \text{ (DIR to B)} = t_{PLZ} \text{ (DIR to A)} + t_{PLH} \text{ (A to B)}$
- $t_{PZL} \text{ (DIR to B)} = t_{PHZ} \text{ (DIR to A)} + t_{PHL} \text{ (A to B)}$

In a bidirectional application, these enable times provide the maximum delay from the time the DIR bit is switched until an output is expected. For example, if the 74AUP1T45 initially is transmitting from A to B, then the DIR bit is switched, the B port of the device must be disabled before presenting it with an input. After the B port has been disabled, an input signal applied to it appears on the corresponding A port after the specified propagation delay.

14. Package outline

Plastic surface-mounted package; 6 leads

SOT363

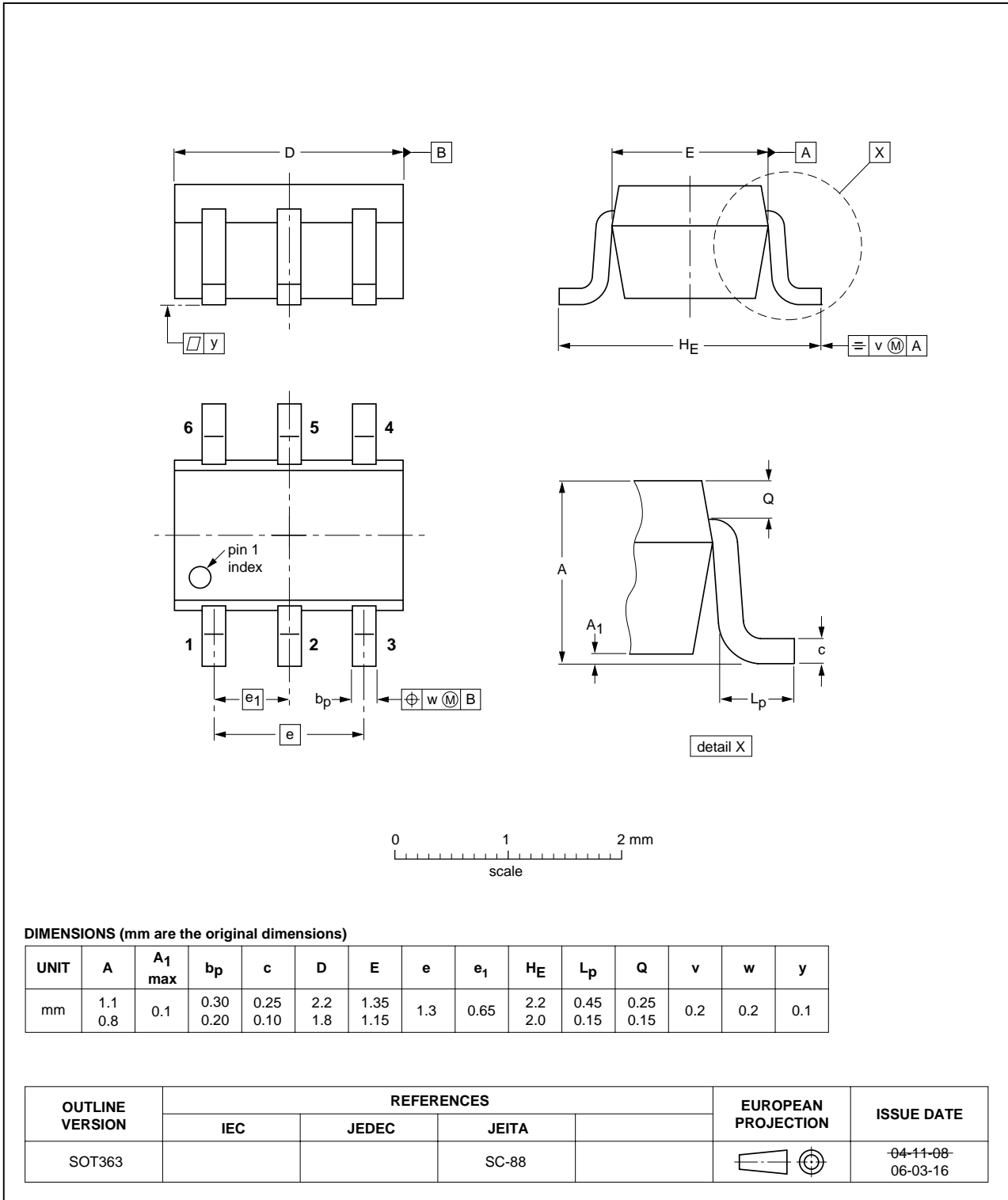

Fig 11. Package outline SOT363 (SC-88)

XSON6: plastic extremely thin small outline package; no leads; 6 terminals; body 1 x 1.45 x 0.5 mm

SOT886

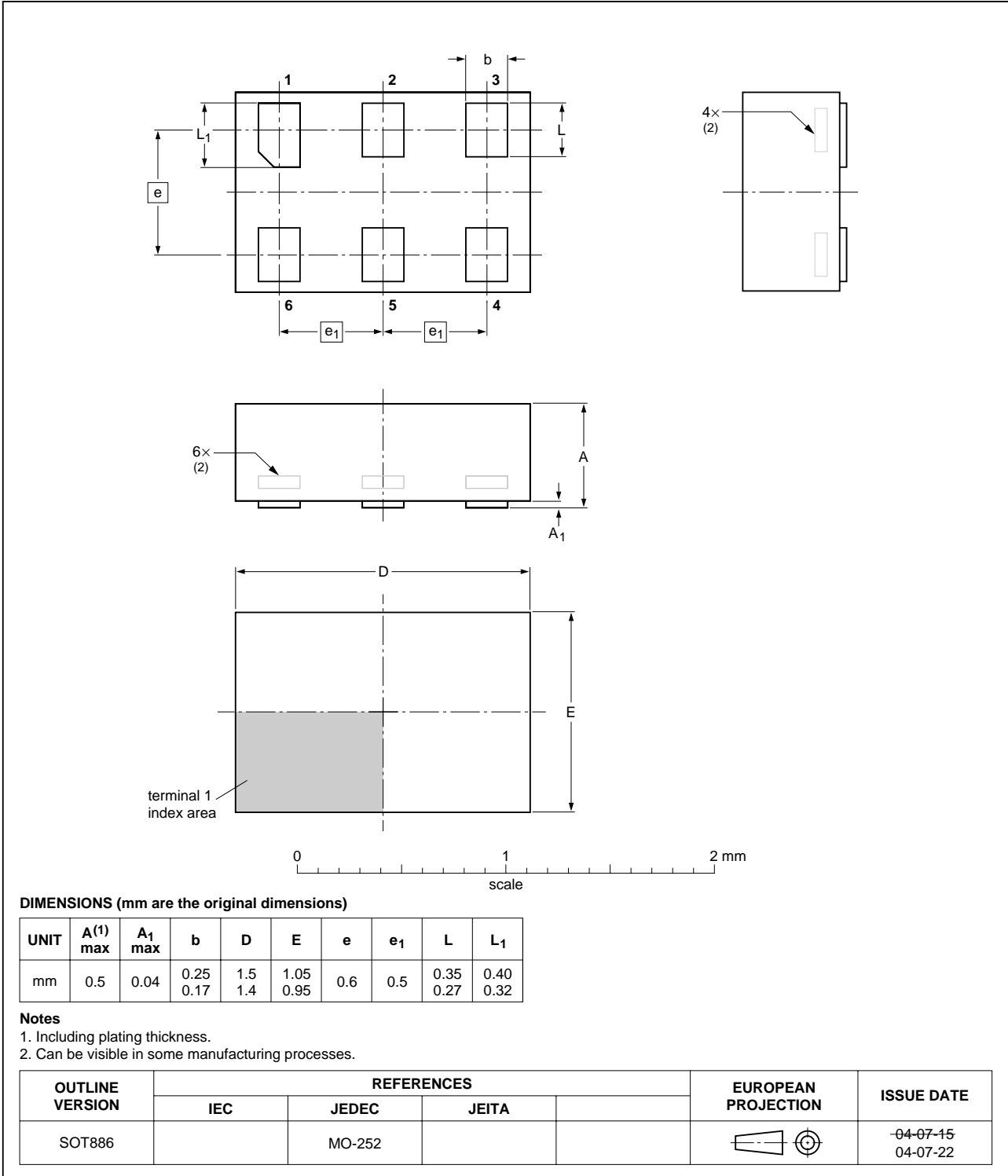

Fig 12. Package outline SOT886 (XSON6)

XSON6: plastic extremely thin small outline package; no leads; 6 terminals; body 1 x 1 x 0.5 mm

SOT891

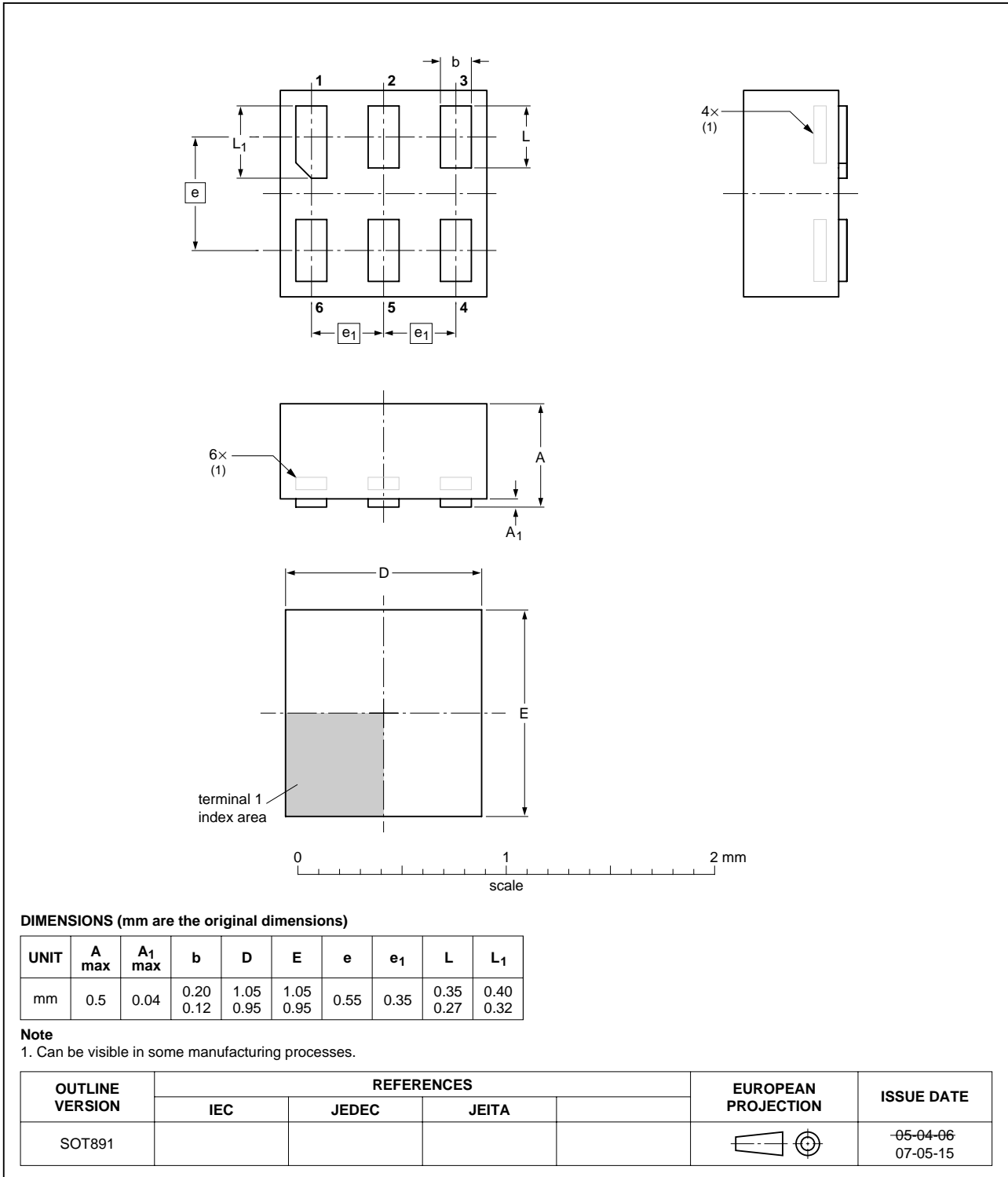

Fig 13. Package outline SOT891 (XSON6)

15. Abbreviations

Table 13. Abbreviations

Acronym	Description
CDM	Charged Device Model
CMOS	Complementary Metal Oxide Semiconductor
DUT	Device Under Test
ESD	ElectroStatic Discharge
HBM	Human Body Model
MM	Machine Model
TTL	Transistor-Transistor Logic

16. Revision history

Table 14. Revision history

Document ID	Release date	Data sheet status	Change notice	Supersedes
74AUP1T45_2	20090803	Product data sheet	-	74AUP1T45_1
Modifications:	<ul style="list-style-type: none">• Table 2 "Marking": Changed: marking code for all packages changed from a5 to p5.			
74AUP1T45_1	20061018	Product data sheet	-	-

17. Legal information

17.1 Data sheet status

Document status ^{[1][2]}	Product status ^[3]	Definition
Objective [short] data sheet	Development	This document contains data from the objective specification for product development.
Preliminary [short] data sheet	Qualification	This document contains data from the preliminary specification.
Product [short] data sheet	Production	This document contains the product specification.

[1] Please consult the most recently issued document before initiating or completing a design.

[2] The term 'short data sheet' is explained in section "Definitions".

[3] The product status of device(s) described in this document may have changed since this document was published and may differ in case of multiple devices. The latest product status information is available on the Internet at URL <http://www.nxp.com>.

17.2 Definitions

Draft — The document is a draft version only. The content is still under internal review and subject to formal approval, which may result in modifications or additions. NXP Semiconductors does not give any representations or warranties as to the accuracy or completeness of information included herein and shall have no liability for the consequences of use of such information.

Short data sheet — A short data sheet is an extract from a full data sheet with the same product type number(s) and title. A short data sheet is intended for quick reference only and should not be relied upon to contain detailed and full information. For detailed and full information see the relevant full data sheet, which is available on request via the local NXP Semiconductors sales office. In case of any inconsistency or conflict with the short data sheet, the full data sheet shall prevail.

17.3 Disclaimers

General — Information in this document is believed to be accurate and reliable. However, NXP Semiconductors does not give any representations or warranties, expressed or implied, as to the accuracy or completeness of such information and shall have no liability for the consequences of use of such information.

Right to make changes — NXP Semiconductors reserves the right to make changes to information published in this document, including without limitation specifications and product descriptions, at any time and without notice. This document supersedes and replaces all information supplied prior to the publication hereof.

Suitability for use — NXP Semiconductors products are not designed, authorized or warranted to be suitable for use in medical, military, aircraft, space or life support equipment, nor in applications where failure or malfunction of an NXP Semiconductors product can reasonably be expected to result in personal injury, death or severe property or environmental

damage. NXP Semiconductors accepts no liability for inclusion and/or use of NXP Semiconductors products in such equipment or applications and therefore such inclusion and/or use is at the customer's own risk.

Applications — Applications that are described herein for any of these products are for illustrative purposes only. NXP Semiconductors makes no representation or warranty that such applications will be suitable for the specified use without further testing or modification.

Limiting values — Stress above one or more limiting values (as defined in the Absolute Maximum Ratings System of IEC 60134) may cause permanent damage to the device. Limiting values are stress ratings only and operation of the device at these or any other conditions above those given in the Characteristics sections of this document is not implied. Exposure to limiting values for extended periods may affect device reliability.

Terms and conditions of sale — NXP Semiconductors products are sold subject to the general terms and conditions of commercial sale, as published at <http://www.nxp.com/profile/terms>, including those pertaining to warranty, intellectual property rights infringement and limitation of liability, unless explicitly otherwise agreed to in writing by NXP Semiconductors. In case of any inconsistency or conflict between information in this document and such terms and conditions, the latter will prevail.

No offer to sell or license — Nothing in this document may be interpreted or construed as an offer to sell products that is open for acceptance or the grant, conveyance or implication of any license under any copyrights, patents or other industrial or intellectual property rights.

Export control — This document as well as the item(s) described herein may be subject to export control regulations. Export might require a prior authorization from national authorities.

17.4 Trademarks

Notice: All referenced brands, product names, service names and trademarks are the property of their respective owners.

18. Contact information

For more information, please visit: <http://www.nxp.com>

For sales office addresses, please send an email to: salesaddresses@nxp.com

19. Contents

1 General description 1

2 Features 1

3 Ordering information 2

4 Marking 2

5 Functional diagram 2

6 Pinning information 3

6.1 Pinning 3

6.2 Pin description 3

7 Functional description 3

8 Limiting values 4

9 Recommended operating conditions 4

10 Static characteristics 5

11 Dynamic characteristics 11

12 Waveforms 23

13 Application information 25

13.1 Unidirectional logic level-shifting application 25

13.2 Bidirectional logic level-shifting application 26

13.3 Power-up considerations 27

13.4 Enable times 27

14 Package outline 28

15 Abbreviations 31

16 Revision history 31

17 Legal information 32

17.1 Data sheet status 32

17.2 Definitions 32

17.3 Disclaimers 32

17.4 Trademarks 32

18 Contact information 32

19 Contents 33

Please be aware that important notices concerning this document and the product(s) described herein, have been included in section 'Legal information'.

