

NXP temperature sensors NE1617A & NE1619

Precise thermal monitoring with small, accurate temp sensors

These programmable, highly accurate temperature sensors, designed for applications where thermal monitoring of hardware and electrical components is critical, have an operating temperature range of 0 to 120 °C and are available in small, 16-pin QSOP packages.

Features

- ▶ NE1617A replaces MAX1617 and ADM1021
- ▶ Monitors internal and remote temperatures
- ▶ No calibration required
- ▶ Programmable alarm for over/under temperature conditions
- ▶ Programmable temperature/voltage limits to control internal alarms – NE1619
- ▶ SMBus 2-wire serial interface
- ▶ NE1617A supply range: 3 to 5.5 V
- ▶ NE1619 supply range: 2.8 to 5.5 V
- ▶ Small 16-pin QSOP package

Applications

- ▶ Desktop and Notebook computers
- ▶ Smart battery packs
- ▶ Industrial controllers
- ▶ Telecom equipment

The NE1617A, a precise, 2-channel sensor, can measure internal and remote temperatures and supports up to nine devices per bus. During normal operation, the sensor updates temperature data at a programmed rate, selectable from 125 ms to 16 seconds. An internal, one-shot command can be used to force a temperature reading as needed.

The NE1619, a more advanced version of the NE1617A, can monitor nine different voltages in addition to the internal and remote temperature. It supports two devices per bus and has programmable temperature and voltage limits for controlling internal alarms. It uses a consistent conversion rate of approximately 500 ms and has an on-chip A/D converter that supports data collection and other functions.

Both sensors are equipped with an internal diode, so they can monitor internal ambient temperatures. They can also measure the internal temperature of a microprocessor that uses an embedded diode. Both sensors are configured as slaves on the SMBus system and communicate via a standard two-wire serial interface (using SCLK and SDATA pins). They support four SMBus protocols: Write Byte, Read Byte, Send Byte, and Receive Byte. Data is transmitted serially in groups of nine bits, using nine clock pulses, including an 8-bit data byte followed by a 1-bit acknowledgement. The system microprocessor is typically used as the master, initiating start, stop, and clock signals.



Typical operating circuit

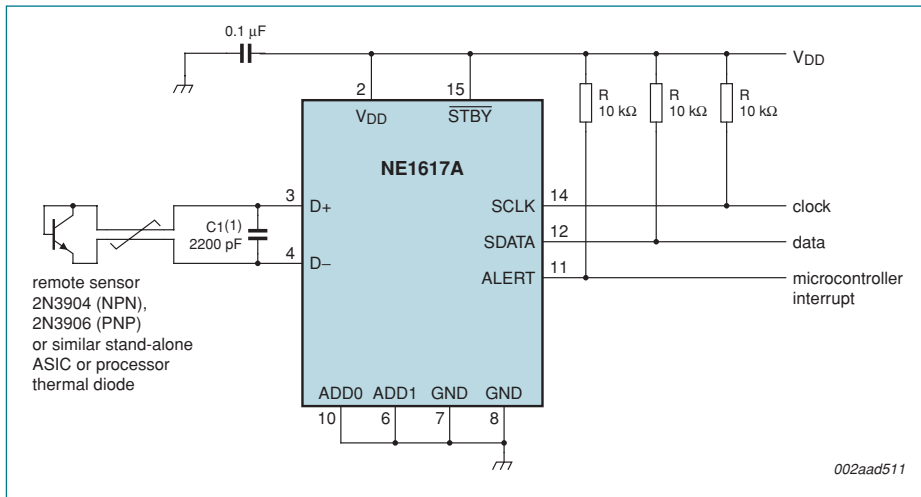

(1) Typical value, placed close to temperature sensor.

Typical operating circuit

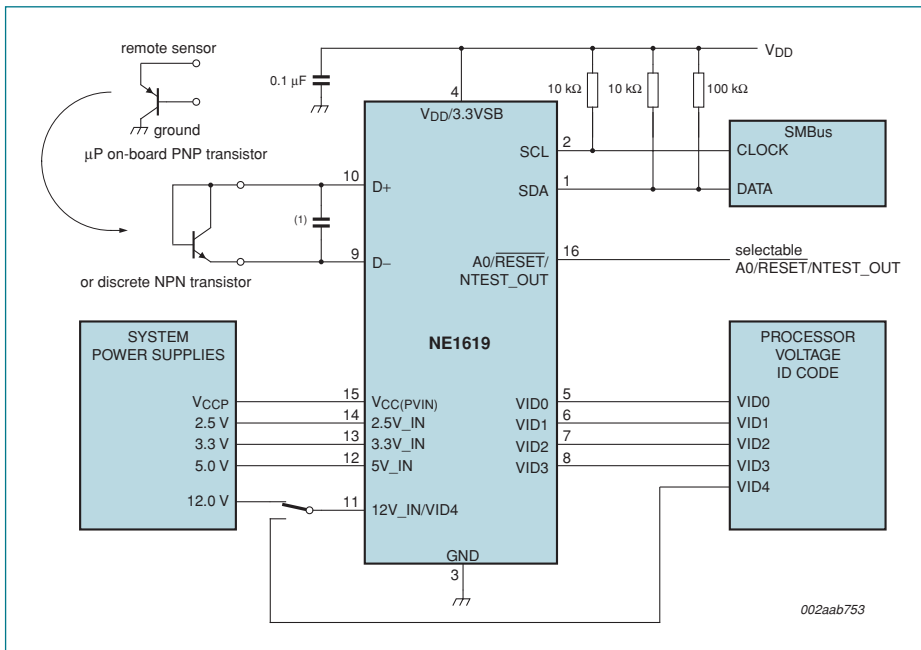

(1) Should be placed close to D+ and D- pins. May be required in noisy environment, about 1 nF.

Selection guide

Feature	NE1617A	NE1619*
Temperature resolution	1 °C	1 °C
Accuracy local (onboard) sensor	± 2 °C	± 2 °C
Accuracy remote sensor	± 3 °C	± 3 °C
Supply range	3 to 5.5 V	2.8 to 5.5 V
Supply current operating mode	70 μA	250 μA
Supply current standby mode	3 μ	100 μ
Package	16-lead QSOP	16-lead QSOP

* Compatible with Intel "Heceta 4" specifications and reference designs that use them.

www.nxp.com/i2clogic

www.nxp.com

founded by

PHILIPS

© 2008 NXP B.V.

All rights reserved. Reproduction in whole or in part is prohibited without the prior written consent of the copyright owner. The information presented in this document does not form part of any quotation or contract, is believed to be accurate and reliable and may be changed without notice. No liability will be accepted by the publisher for any consequence of its use. Publication thereof does not convey nor imply any license under patent- or other industrial or intellectual property rights.

Date of release: August 2008

Document order number: 9397 750 16533

Printed in the Netherlands